



Lighting Mitigation Plan
For



Kerr McGee Oil & Gas Onshore LP

LARKSPUR FED PAD

Project Number: 21010-40

Originators:	<u>E. Olagoke</u>	Date	<u>02-19-24</u>
Project Engineer Approval:	<u>R. Morris</u>	Date	<u>02-19-24</u>
Project Manager Approval:	<u>M. Fortney</u>	Date	<u>02-19-24</u>
Client Review:	<u>Justin Nelson</u>	Date	<u> </u>

Rev. No.	By	Revisions	Approval	Date
0	E00	Issued for Attachment to Permit	MF	02-22-24

TABLE OF CONTENTS

1.0 EXECUTIVE SUMMARY 3

2.0 INTRODUCTION AND DEFINITION OF TECHNICAL TERMS 3

 2.1 INTRODUCTION 3

 2.2 DEFINITION OF TECHNICAL TERMS 3

3.0 MODEL AND ANALYSIS DEVELOPMENT 5

4.0 ECMC LIGHTING ANALYSIS RESULTS 6

 4.1 CUMULATIVE LIGHTING IMPACTS 6

 4.2 SITE LIGHTING POSITIONS AND ORIENTATIONS 8

5.0 WELD COUNTY LIGHTING ANALYSIS RESULTS 9

 5.1 HARDSCAPE AND LUMEN LEVEL RESULTS 9

6.0 SITE PLANS & FIXTURE SCHEDULES 10

 6.1 DRILLING PHASE 10

 6.2 COMPLETIONS PHASE 10

 6.3 PRODUCTION PHASE 11

7.0 SITE MITIGATION NOTES AND BEST MANAGEMENT PRACTICES 12

8.0 ATTACHMENTS 14

1.0 EXECUTIVE SUMMARY

Kerr McGee Oil & Gas Onshore LP (KMOG) commissioned Samuel Engineering to develop a lighting mitigation plan for the Larkspur Fed pad site. The purpose of this report is to demonstrate compliance with the State and Local lighting regulations, predict lighting impacts for the different development phases, and to detail the various lighting mitigation techniques used to limit the amount of light leaving the location.

Site specific three-dimensional lighting models were developed for each of the phases to determine their associated lighting impacts. The lighting fixtures used in the models were selected based on currently operated representative sites and research conducted into available vendor lighting systems.

Table 1.0 summarizes the modeled maximum values and shows that all values are within the regulatory limits:

Modeled Lighting Values and Regulatory Limits Summary				
Phase	Sub Phase	Max Modeled Value	Allowance Limit	Regulating Agency
All	All	0.43 lux	≤ 4.0 lux	ECMC
Construction	Drilling	2.52 lm/ft ²	≤ 12 lm/ft ²	Weld County
	Completions	1.73 lm/ft ²	≤ 12 lm/ft ²	Weld County
Production	Production	0.02 lm/ft ²	≤ 1.25 lm/ft ²	Weld County

Table 1.0 - Modeled Lighting Values and Regulatory Limits

2.0 INTRODUCTION AND DEFINITION OF TECHNICAL TERMS

2.1 INTRODUCTION

Light mitigation plans seek to quantify and prescribe methods to address the effects of multiple forms of light. Effective lighting mitigation plans address light impacts by limiting the impacts on the surrounding areas, preserving the overall night-sky aesthetics, and maintaining existing ecosystems, all while maintaining a safe work environment.

There are a number of standards, best practices, and regulations which are used as guidelines when developing lighting plans for reducing the effects of artificial lighting. The applicable regulations used for this report are ECMC Rule 424 and Weld County Ordinance ORD2021-17.

2.2 DEFINITION OF TECHNICAL TERMS

A number of technical terms are used throughout this report and, as an aid to the reader, are defined below.

Illuminance (lx)

Illuminance is defined as the amount of light falling on a surface area. It is measured in Lux (lx) or foot-candles (fc). One lux is equal to one lumen per square meter. One foot-candle is equal to one lumen per square foot, or 10.7639 lux.

It should be noted that the measured value is dependent on angle, sensitivity, and optics. As an example, the photo in Figure 2.2 shows the lux levels decreasing on the sidewalk, as the distance from the light source increases.

Table 2.2 provides examples of typical Lux values.

Typical Lux Values	
Clear night, no moon:	0.002 lx
Clear night, full Moon:	0.27 to 1 lx
Family Living Room	50 lx
Sunrise/sunset	300-500 lx
Overcast day:	1000 lx
Daylight:	10,000-25,000 lx
Direct sunlight:	32,000-130,000 lx

Table 2.2 – Typical Lux Values

Luminous Flux (lm)

Luminous Flux is defined as the amount of light energy produced per unit time and is measured in Lumens (lm). It is a physical property of light and, in general terms, is a measurement of the total amount of light power emanating from a source.

It is important to note that the luminous flux value of a given source is independent of where a measurement is taken. For example, a 60-watt incandescent light bulb produces approximately 800 lumens, regardless of if the measurement is taken at 1 foot, 10 miles, or 10,000 miles away from the source.

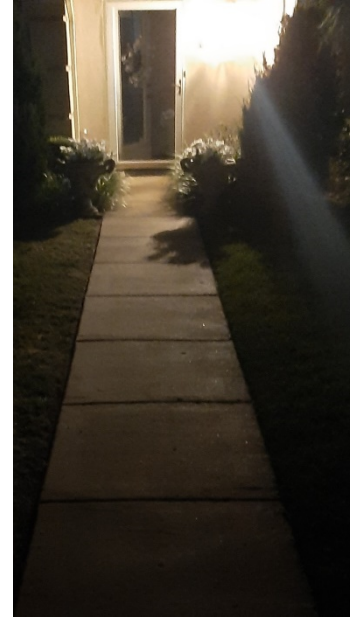

Figure 2.2–Illuminance (lx) level decreasing with distance from light source.

3.0 MODEL AND ANALYSIS DEVELOPMENT

Site-specific three-dimensional models were developed for each of the major project development phases. These phases being Drilling, Completions/Flowback (summarized as Completions in this report), and Production. The following elements were incorporated into the models: the local site topographical information, major lighting obstructions (sound walls, large equipment, etc...), individual luminaire lighting qualities, lighting mounting characteristics and surrounding building units.

Geographical information was obtained using USGS topography data to model the surrounding landscape.

To determine the lighting impacts on local building units, 25-foot vertical walls were modeled at the units' locations, at the USGS identified elevations.

Modeling of site-specific information (including large equipment, type of luminaire, and any sound wall locations) is based on inspections of operational representative sites, provided vendor information, and research into various available lighting systems. The major pieces of equipment modeled included:

- Drilling: Drill rig floor, derrick, substructure, temporary lighting, sound barriers, backyard, and trailers.
- Completions: Temporary lighting, sound barriers, completion fleet equipment, and trailers.
- Production: LACT skids, separators, large tanks, and associated equipment.

Once site-specific topographical information and equipment are modeled, lighting characteristics are placed within the model. These characteristics are obtained from the various manufacturers and are specific to the make/model of the light to be used. The following information is included in the model: the luminaire type, quantity, mounting height, orientation, and tilt angle.

Models for each of the phases were developed and the resulting lighting impacts were tabulated. A spreadsheet was used to total the site lumens for each fixture and compare it to the site working pad surface or hardscape area.

During Pre-Production, temporary lighting fixtures were based on currently available rental units and on observations from representative sites. The temporary lighting system that will be used may vary based on rental availability, but should be similar to the lumen values used in this analysis.

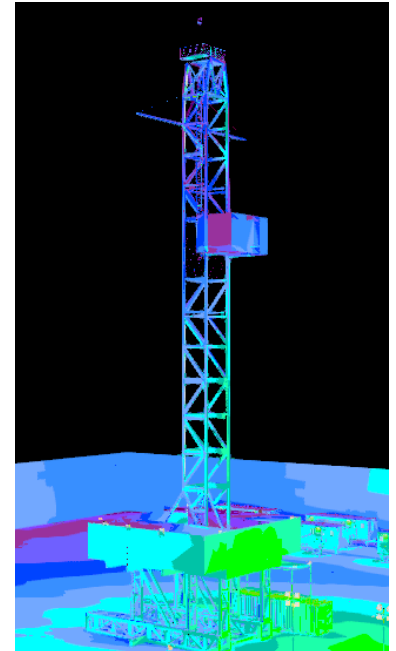

Figure 3.0 – Screenshot from a representative 3-D model showing a false color rendering

4.0 ECMC LIGHTING ANALYSIS RESULTS

4.1 CUMULATIVE LIGHTING IMPACTS

For modeling purposes, buildings were grouped into clusters and a representative "wall" location was selected for analysis. These analyzed "wall" locations were selected to determine an upper cumulative light impact limit for that clustered group, considering the local topography, orientation, and distance to the site.

Table 4.1 shows the modeled lux values at each wall location.

Calculated Lighting Impact Results Building Units				
Location Unit No.	Drilling	Completions	Production	Regulatory Limit
1	0.14 lux	0.43 lux	< 0.1 lux	4 lux
2	< 0.1 lux	0.12 lux	< 0.1 lux	4 lux
3	< 0.1 lux	< 0.1 lux	< 0.1 lux	4 lux
4	< 0.1 lux	0.13 lux	< 0.1 lux	4 lux
5	0.10 lux	0.16 lux	< 0.1 lux	4 lux
6	0.21 lux	0.18 lux	< 0.1 lux	4 lux
7	< 0.1 lux	< 0.1 lux	< 0.1 lux	4 lux
8	0.10 lux	< 0.1 lux	< 0.1 lux	4 lux
9	< 0.1 lux	< 0.1 lux	< 0.1 lux	4 lux
10	< 0.1 lux	< 0.1 lux	< 0.1 lux	4 lux
11	< 0.1 lux	< 0.1 lux	< 0.1 lux	4 lux
12	< 0.1 lux	< 0.1 lux	< 0.1 lux	4 lux
13	< 0.1 lux	< 0.1 lux	< 0.1 lux	4 lux

Table 4.1 – Calculated Lighting Impact Results Building Units

Figure 4.1 shows the building units that are located within a 1-mile radius of the Larkspur Fed pad site.

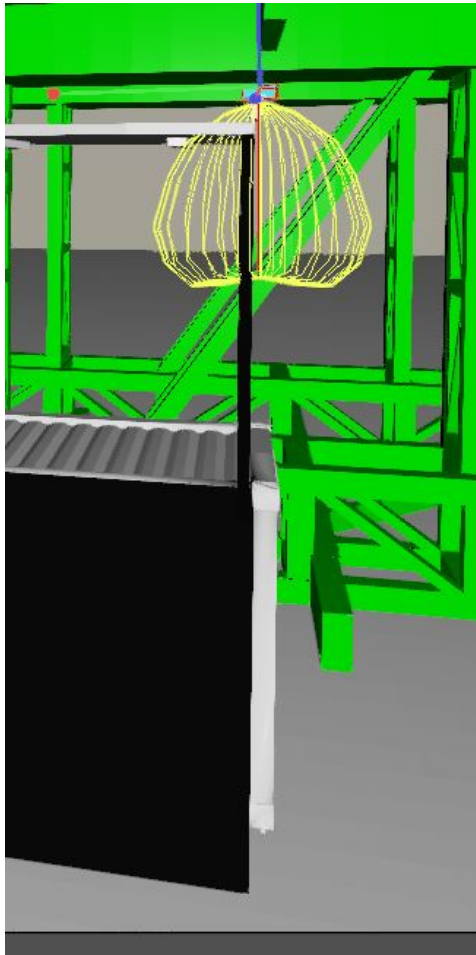

Figure 4.1 – Building Units Within a 1-Mile Radius of Larkspur Pad

4.2 SITE LIGHTING POSITIONS AND ORIENTATIONS

The following figures and tables in this section show the lighting location, mounting, height, and orientations for the Drilling, Completions, and Production Operations, in accordance with ECMC Rule 424(a)(2)(A)(ii). The following notes apply:

- 1) Stated tilt at zero (0) degrees represents a luminaire facing directly downward.



Example 0 degrees

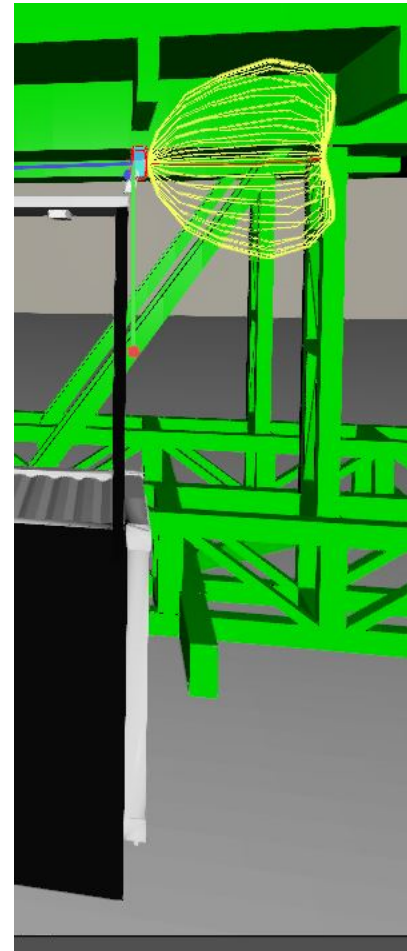

Example 90 degrees

- 2) Intermittent sources of lights such as glow from on-site combustor and alarm lights are not included in this analysis.
- 3) Temporary lighting, where necessary for safety reasons per ECMC 424.a.2.A.iii, have not been modeled or accounted for in this analysis.
- 4) The quantity of lights and calculated values shown represents an estimated upper limit to the actual values that will be present on-site.
- 5) Refer to Attachment B for further lighting fixture information.

5.0 WELD COUNTY LIGHTING ANALYSIS RESULTS

5.1 HARDSCAPE AND LUMEN LEVEL RESULTS

Lumens per Hardscape calculations were performed based on the number of exterior fixtures, light output (lumens), and the working pad surface (hardscape). These values were then compared to the allowed site lumens per square foot to demonstrate compliance.

Table 5.1 summarizes the lumen values and compares them to typical lighting limits.

Lumens Per Hardscape Area			
Phase:	Construction Phase: Drilling	Construction Phase: Completions	Production Phase
Hardscape Area:	10.15 acres / 442,134 ft ²	10.15 acres / 442,134 ft ²	10.15 acres / 442,134 ft ²
Total Lumens:	1,113,558 lm	766,320 lm	9,860 lm
Calculated Lumens/ft²:	2.52 lm/ft ²	1.73 lm/ft ²	0.02 lm/ft ²
Allowable Limit:	≤ 12 lm/ft ²	≤ 12 lm/ft ²	≤ 1.25 lm/ft ²

Table 5.1 – Lighting Compliance with Typical Lighting Limits

6.0 SITE PLANS & FIXTURE SCHEDULES

6.1 DRILLING PHASE

Refer to:
 Drawing 21010-EE-508 for Drilling Phase Photometric
 Drawing 21010-EE-511 for Drilling Phase Shaded View

Fixture Schedule - Drilling Phase										
Luminaire ID	Manufacturer	Catalog No.	Description	Power (W)	Luminous Flux (lm)	Luminaire No.	Luminaire Height (ft. above grade)	Luminaire Tilt (degrees)	Quantity	Total Lumens (lm)
B	HPWINNER	M8B-VCA-63	POLE-MOUNTED PORTABLE LIGHT PLANT, EACH FIXTURE CONSISTS OF 16 MODULES, VALUES GIVEN ARE TOTAL PER FIXTURE	960 W	121,920	1-2	30'	75°	2	243,840
C	PAULUHN	DFLMY400/TT 76	WALL-MOUNTED FLOODLIGHT	400 W	24,091	3-10	21'	75°	8	192,728
						55-64	36'	75°	10	240,910
						79-82	20'	75°	4	96,364
D	PAULUHN	DLL4/UNV1S903D	WALL-MOUNTED LINEAR 4FT. LED, INCLUDES DIFFUSED POLYCARBONATE LENS	63 W	7,900	11-13	20'	0°	3	23,700
						14-40	9'	75°	27	213,300
						67	53'	90°	1	7,900
						68	61'	90°	1	7,900
						69	73'	90°	1	7,900
						70	82'	90°	1	7,900
						71	92'	90°	1	7,900
						72	149'	90°	1	7,900
						73	158'	90°	1	7,900
						74-78	19'	0°	5	39,500
E	PAULUHN	DLL2/UNV1S903D	WALL-MOUNTED LINEAR 2FT. LED, INCLUDES DIFFUSED POLYCARBONATE LENS	32 W	3,958	65	41'	90°	1	3,958
						66	167'	90°	1	3,958
Drilling Phase Total Lumens:										1,113,558

6.2 COMPLETIONS PHASE

Refer to:
 Drawing 21010-EE-509 for Completions Phase Photometric
 Drawing 21010-EE-512 for Completions Phase Shaded View

Fixture Schedule - Completions Phase										
Luminaire ID	Manufacturer	Catalog No.	Description	Power (W)	Luminous Flux (lm)	Luminaire No.	Luminaire Height (ft. above grade)	Luminaire Tilt (degrees)	Quantity	Total Lumens (lm)
A	STANPRO	WPS-PS40-Q-3C	WALL-MOUNTED WALL PACK LED	40 W	5,800	83-88	11'	0°	6	34,800
B	HPWINNER	M8B-VCA-63	POLE-MOUNTED PORTABLE LIGHT PLANT, EACH FIXTURE CONSISTS OF 16 MODULES, VALUES GIVEN ARE TOTAL PER FIXTURE	960 W	121,920	89-92, 93A, 93B	30'	75°	6	731,520
Completions Phase Total Lumens:										766,320

6.3 PRODUCTION PHASE

Refer to:
 Drawing 21010-EE-510 for Production Phase Photometric
 Drawing 21010-EE-513 for Production Phase Shaded View

Fixture Schedule - Production Phase										
Luminaire ID	Manufacturer	Catalog No.	Description	Power (W)	Luminous Flux (lm)	Luminaire No.	Luminaire Height (ft. above grade)	Luminaire Tilt (degrees)	Quantity	Total Lumens (lm)
F	RAYCHEM	E-100-L-A	HEAT TRACE VERTICAL END SEAL KIT LIGHT, FIXTURE IS AN ESTIMATE OF TYPICAL END SEAL KIT LIGHTS	2 W	60	94-124	5'	180°	31	1,860
G	PHOENIX	CL-13LED-120-240	COMPACT LED AREA CUBE LIGHT, INCLUDES VISOR KIT (#VSR-CL) TO MITIGATE UPLIGHT	13 W	1,000	125-132	9'	0°	8	8,000
Production Phase Total Lumens:										9,860

7.0 SITE MITIGATION NOTES AND BEST MANAGEMENT PRACTICES

Construction Phase:

- During construction of all phases, KMOG will only conduct day light operation and there will be no nighttime operations that require lighting.
- Exterior lighting shall be directed away from residential and other sensitive areas or shielded from said areas to eliminate glare. Light spillage beyond the perimeter of the well site shall be minimized.
- Bulbs shall be fully shielded to prevent light emissions above a horizontal plane drawn from the bottom of each fixture.

Drilling Phase:

- KMOG will utilize LED fixtures to reduce skyglow.
- KMOG will position all lights to point in a downward direction where vertical lighting is not required. Where it is required, lights are angled in a vertical direction to provide task lighting for safety and operations involving personnel.
- Derrick mast lighting in Section 6.1 is facing horizontally to provide adequate lighting for safe operation.
- Lighting is angled to mitigate the amount of light leaving the location boundary, and away from surrounding off site buildings.
- Lighting within the Drilling area has been reduced to provide a minimum acceptable value for safe operation.
- Light masts are automatically switched off/on based on lighting sensors.
- Lights are switched off when not required.
- Low power (63 W) LED lights are used for the drill rig.
- In the event of a lighting complaint, KMOG will address the complaint and work with all parties involved to ensure the complaint is resolved.

Completions and Flowback Phases:

- KMOG will utilize LED fixtures to reduce skyglow.
- KMOG will position all lights to point in a downward direction where vertical lighting is not required. Where it is required, lights are angled in a vertical direction to provide task lighting for safety and operations involving personnel.
- Lighting is angled to mitigate the amount of light leaving the location boundary, and away from surrounding off site buildings.
- Lighting within the Completion and Flowback areas have been reduced to provide a minimum acceptable value for safe operation.
- Light masts are automatically switched off/on based on lighting sensors.
- Lights are switched off when not required.
- Lights are directed to task areas only.
- In the event of a lighting complaint, KMOG will address the complaint and work with all parties involved to ensure the complaint is resolved.

Production Phase:

- KMOG will utilize LED fixtures to reduce skyglow.
- KMOG will position all lights to point in a downward direction, in order to mitigate light leaving the location boundary.

- Lighting within the Production areas have been reduced to provide a minimum acceptable value for safe operation.
- In the event of a lighting complaint, KMOG will address the complaint and work with all parties involved to ensure the complaint is resolved.

1) Lighting Cut Sheet Notes for Attachment B

1. Type A Fixtures (Pre-Production Phase)

- Type A fixtures are construction trailer lights. These units vary significantly depending on supplier, rental agency, inventory, and current market available fixtures. Lights varied significantly during site inspections. A representative model was selected based on a lumen output for a trailer.

2. Type B Fixtures (Pre-Production Phase)

- Type B fixtures are portable construction light towers with vertical masts. These units vary significantly depending on supplier, rental agency, inventory, and current market available fixtures. HP Winner M8B Model was selected for this analysis based on site inspections and current available units; however specific site units may vary based on time of construction. The model for these portable light towers consisted of a LED light source with 4 fixtures. Each of these fixtures were comprised of 4 LED modules mounted in a rectangular arrangement. The attached cut sheet for HP Winner represents 1 LED module.
- The typical light pole center of fixtures is raised approximately 30 feet from grade and pointed downward toward work area.
- The fixture mounting for portable light towers are articulated mountings which allows for both vertical and horizontal plane adjustments. For this analysis, the light mast fixtures were modeled at indicated angles.

3. Type C Fixtures (Pre-Production Phase) are representative of current fixtures used during drilling operations.

4. Type D Fixtures (Pre-Production Phase) are representative of current fixtures used during drilling operations.

5. Type E Fixtures (Pre-Production Phase) are representative of current fixtures used during drilling operations.

6. Type F Fixtures (Production Phase)

- Type F Fixtures is an estimation of heat trace end kits. Photometric data from the manufacturer is not available. These lights are low power LED's mounted on the pipe where heat trace is installed. Mounting height, and location vary based on final design and installation.

7. Type G Fixtures (Production Phase) are representative of current fixtures used for LACT skids and mounted near the doors to the skids.

8.0 ATTACHMENTS

Attachment A – 21010 Larkspur Fed Pad Site Lighting Plans

Attachment B – 21010 Larkspur Fed Pad Lighting Fixture Cut Sheets Attachment

END OF REPORT

ATTACHMENT A
SITE LIGHTING PLANS
LIGHTING MITIGATION PLAN
FOR
KERR MCGEE OIL & GAS ONSHORE LP
LARKSPUR FED PAD
Project Number: 21010-40

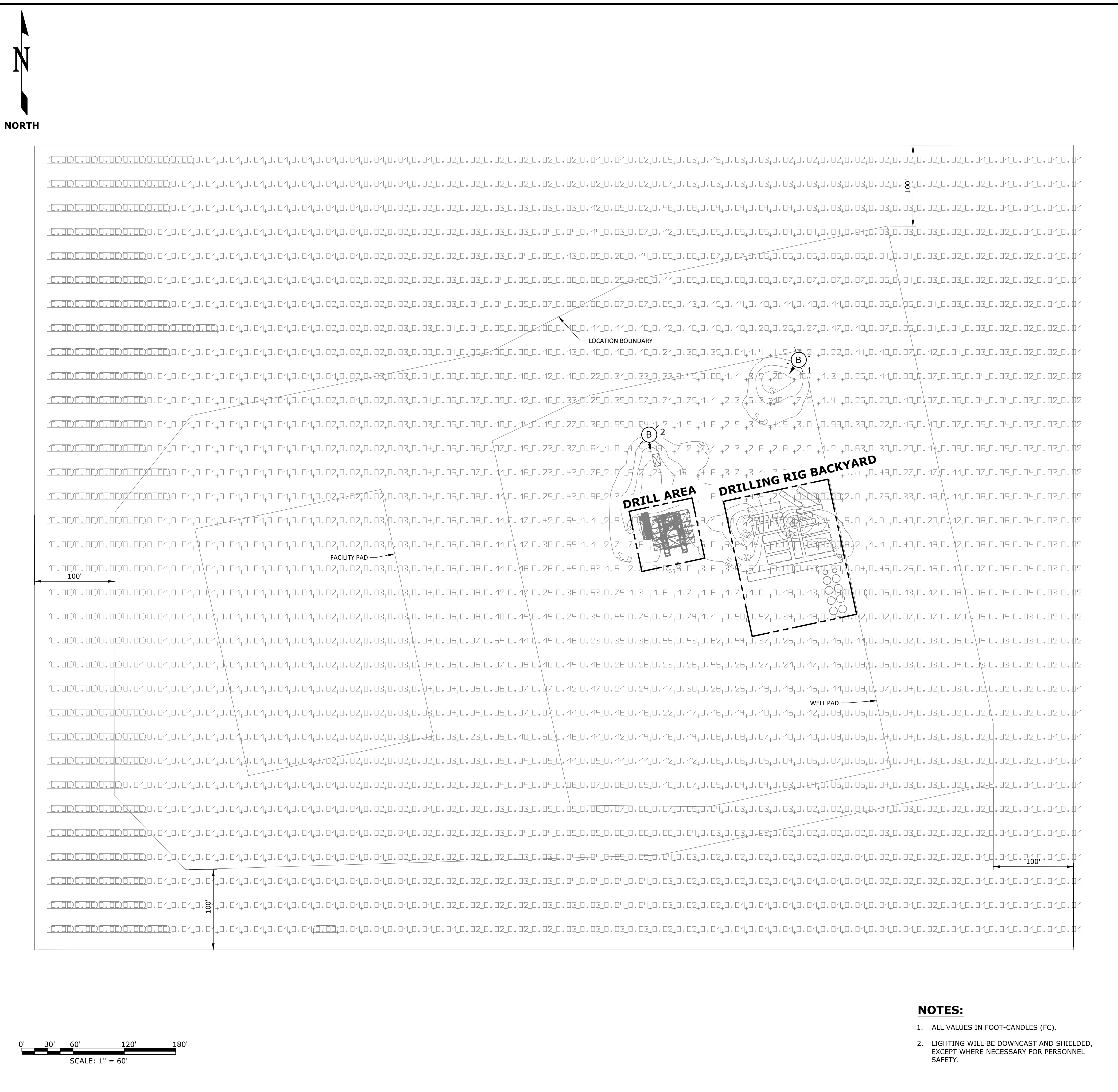
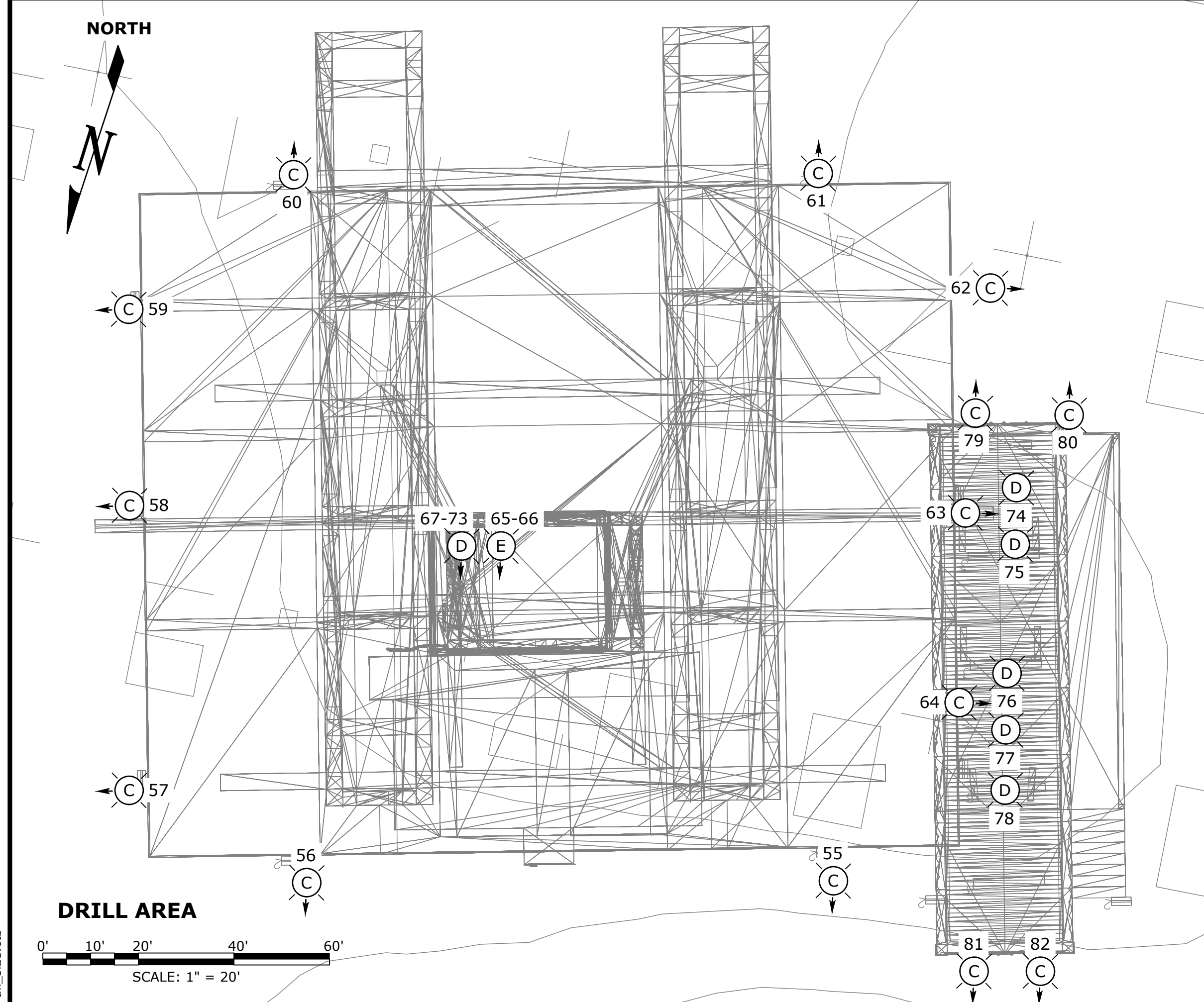
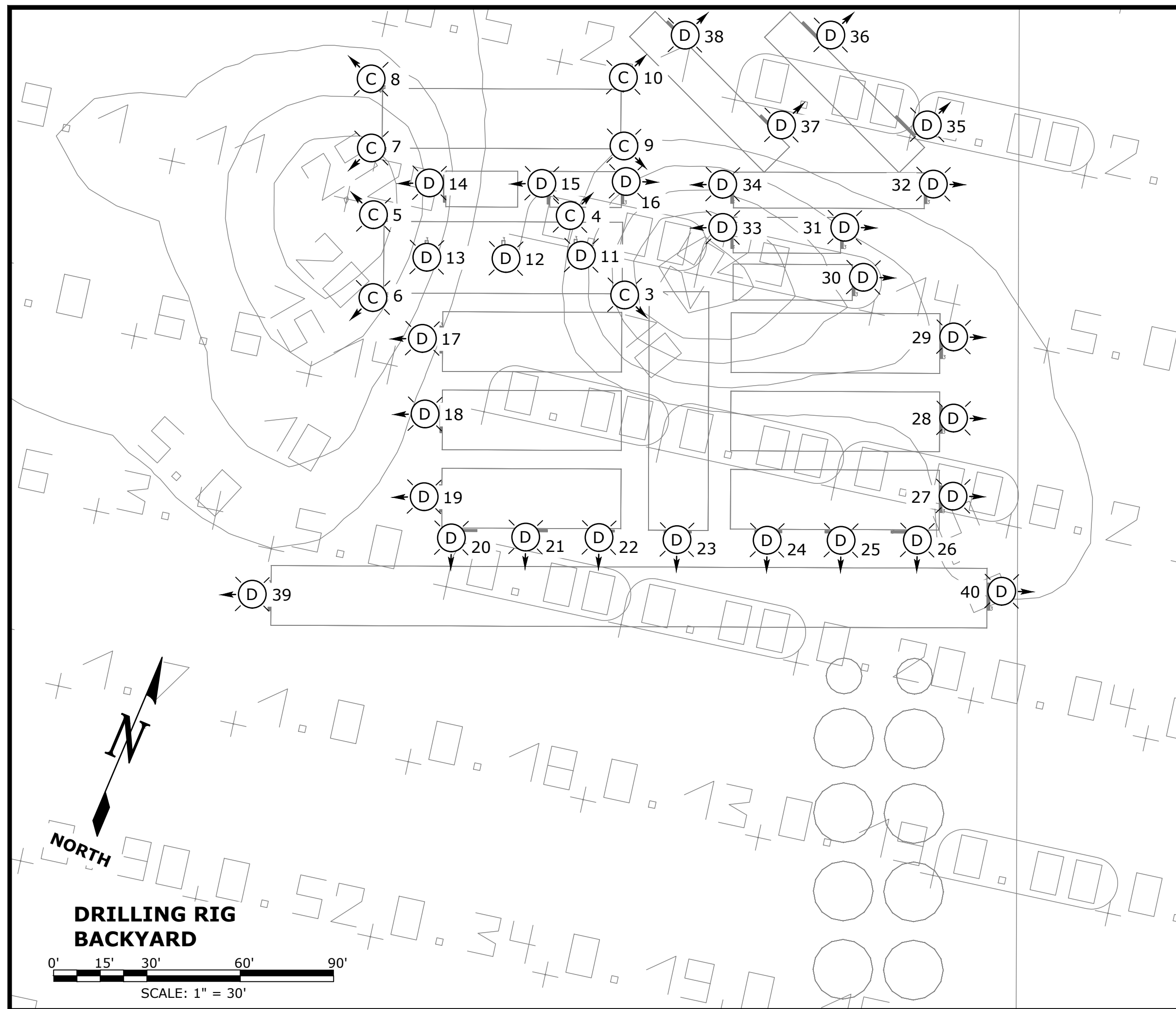

- NOTES:**
- ALL VALUES IN FOOT-CANDLES (FC).
 - LIGHTING WILL BE DOWNCAST AND SHIELDED, EXCEPT WHERE NECESSARY FOR PERSONNEL SAFETY.

CAD File: S:\Projects\21010_Oxy_Lighting_Studies\CAD\Drawings\Physical Plans\21010-EE-508.dwg
 Plot Date: Wednesday, February 21, 2024 11:08:43 AM Plotted By: Adam Ramirez
 CTB Used: SE_Std_L&W_Full_size.ctb

This document is copyrighted and is an instrument of service by Samuel Engineering (SE). It was prepared solely for the Owner's/Client's use on this project only. Use, copy or disclosure of any information shown, in whole or in part, without SE's consent, is strictly prohibited, is a copyright breach and may be prosecuted. Any unauthorized reuse shall be at the sole risk of the user.

NUMBER	TITLE

CLIENT	PROJECT MANAGER	PROJECT ENGINEER	CHECK

NO.	DESCRIPTION	DATE	BY

CLIENT	PROJECT MANAGER	PROJECT ENGINEER	CHECK

NO.	DESCRIPTION	DATE	BY
0	ISSUED FOR ATTACHMENT TO PERMIT	02/22/24	AR

SCALE:	AS NOTED	DATE:	
DESIGNED:	A. RAMIREZ	02/22/24	
DRAWN:	A. RAMIREZ	02/22/24	
CHECKED:	L.OHL	02/22/24	
PE APPROVED:	R.MORRIS	02/22/24	
PM APPROVED:	M.FORTNEY	02/22/24	

CLIENT: KERR MCGEE
 PROJECT LOCATION: WELD COUNTY, CO

8450 E. Crescent Parkway, Suite 200
 Greenwood Village, CO 80111
 Phone: 303.714.4840
 Fax: 303.714.4800
 Web: samuelengineering.com

TITLE	PROJECT NUMBER
LIGHTING STUDY WELD COUNTY ELECTRICAL LARKSPUR FED PAD PHOTOMETRIC LIGHTING PLAN - DRILLING	21010
DRAWING NUMBER	21010-EE-508

REV.
0

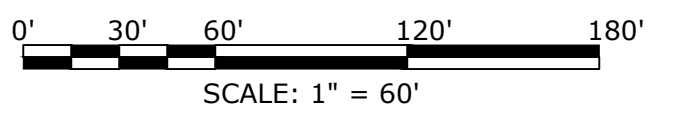
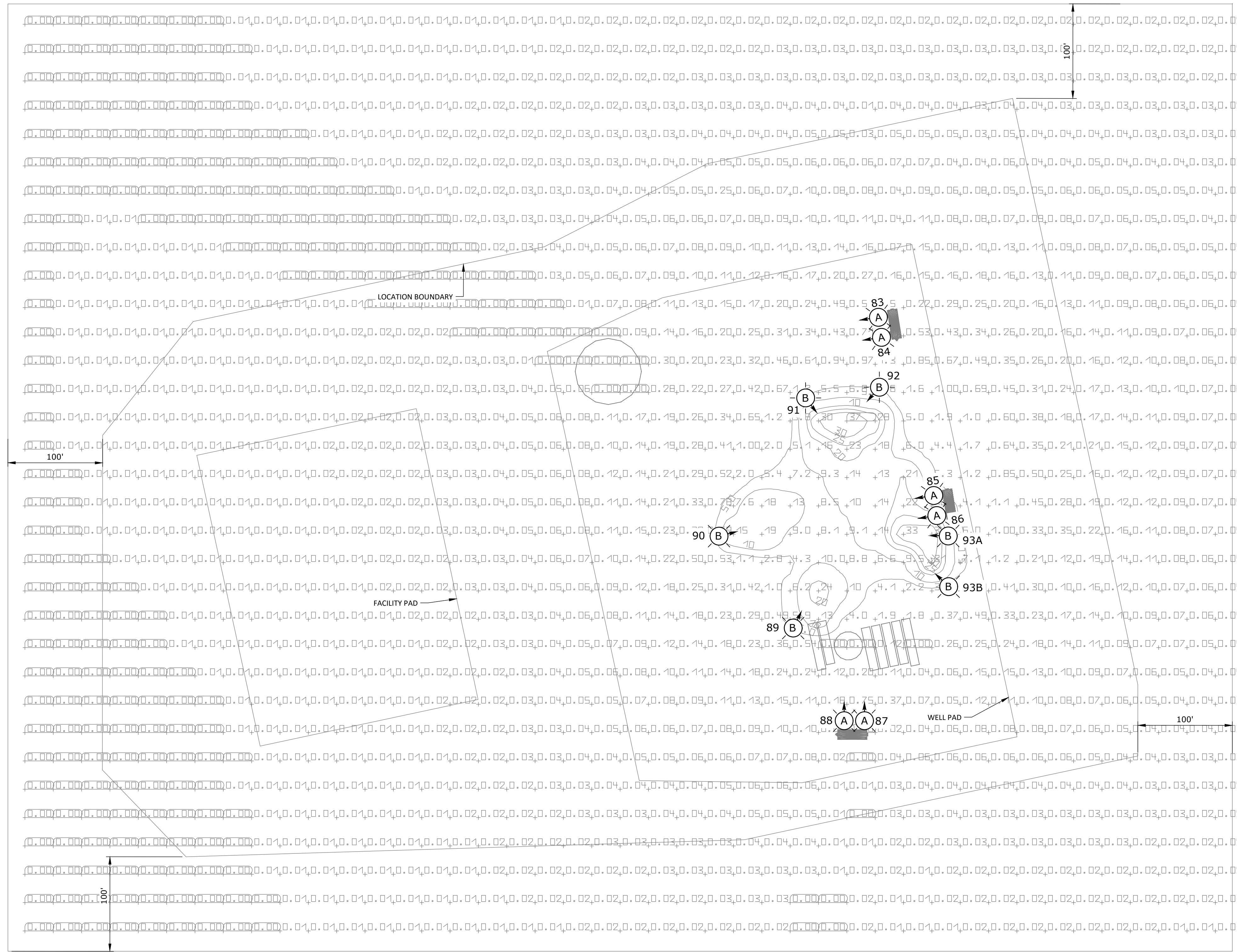

NOTES:

1. ALL VALUES IN FOOT-CANDLES (FC).
2. LIGHTING WILL BE DOWNCAST AND SHIELDED, EXCEPT WHERE NECESSARY FOR PERSONNEL SAFETY.

CAD File: S:\Projects\21010_Oxy_Lighting_Studies\CAD\Electrical\Drawings\Physical Plans\21010-EE-509.dwg
 Plot Date: Wednesday, February 21, 2024 11:09:06 AM Plotted By: Adam Ramirez
 CTB Used: SE_Std_B&W_Full_Size.ctb

This document is copyrighted
 and is an instrument of service
 by Samuel Engineering (SE). It
 was prepared solely for the
 Owner's/Client's use on this
 project only. Use, copy or
 disclosure of any information
 shown, in whole or in part,
 without SE's consent, is strictly
 prohibited, is a copyright breach
 and may be prosecuted. Any
 unauthorized reuse shall be at
 the sole risk of the user.

NUMBER	TITLE

NO.	DESCRIPTION	DATE	BY

NO.	DESCRIPTION	DATE	BY

NO.	DESCRIPTION	DATE	BY
0	ISSUED FOR ATTACHMENT TO PERMIT	02/22/24	AR

SCALE: AS NOTED DATE: 02/22/24
 DESIGNED: A. RAMIREZ 02/22/24
 DRAWN: A. RAMIREZ 02/22/24
 CHECKED: L.OHL 02/22/24
 PE APPROVED: R.MORRIS 02/22/24
 PM APPROVED: M.FORTNEY 02/22/24

SE SAMUEL ENGINEERING
 WE PROVIDE SOLUTIONS

8450 E. Crescent Parkway, Suite 200
 Greenwood Village, CO 80111
 Phone: 303.714.4840
 Fax: 303.714.4800
 Web: samuelengineering.com

TITLE	PROJECT NUMBER
LIGHTING STUDY WELD COUNTY ELECTRICAL LARKSPUR FED PAD PHOTOMETRIC LIGHTING PLAN - COMPLETIONS	21010
	DRAWING NUMBER
	21010-EE-509

REV.	
0	

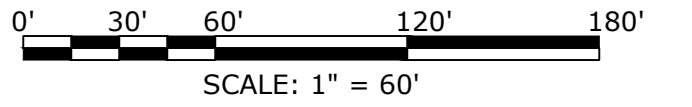
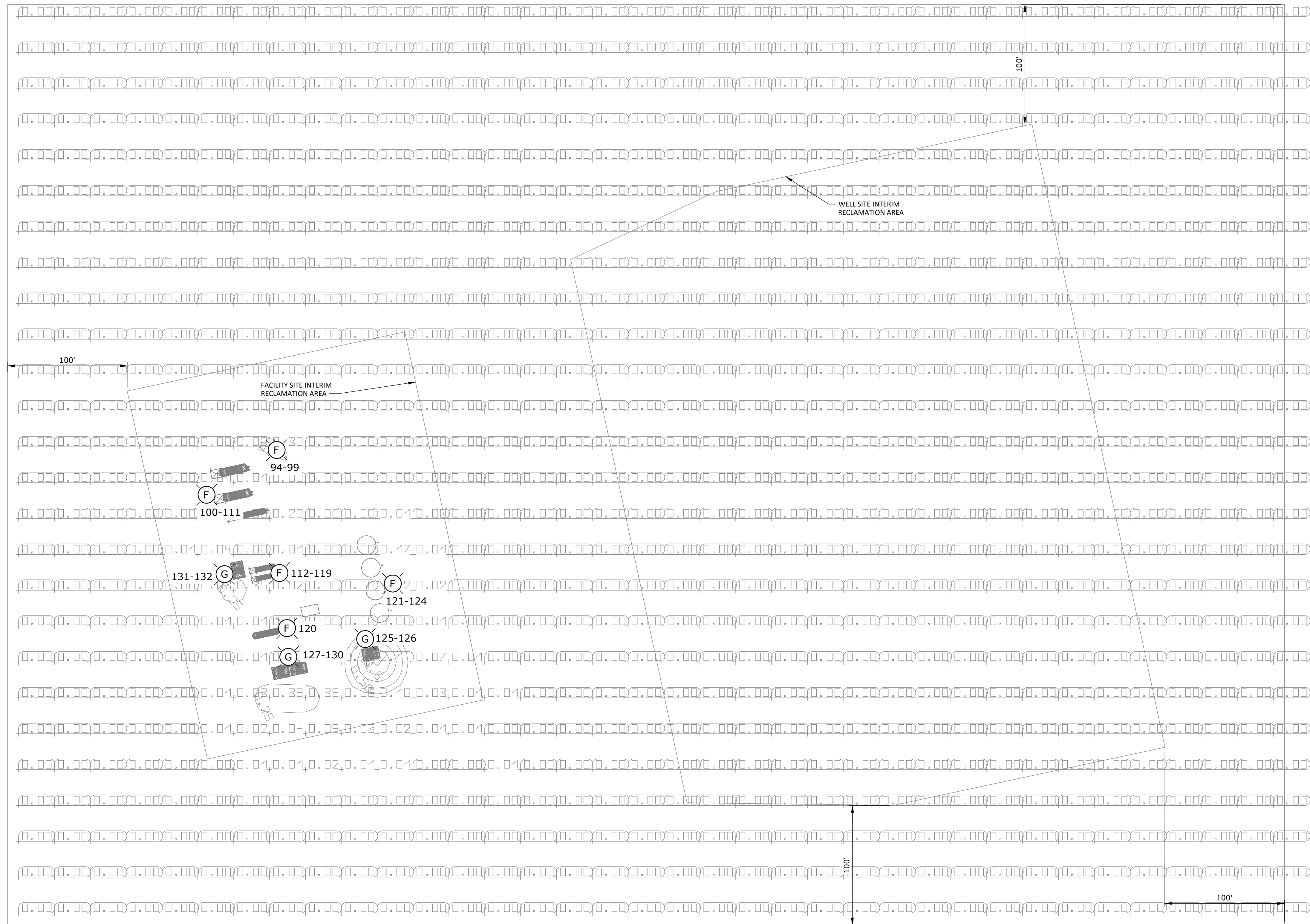
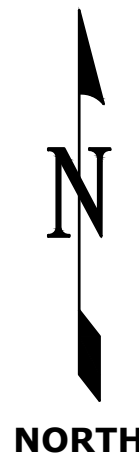

NOTES:

1. ALL VALUES IN FOOT-CANDLES (FC).
2. LIGHTING WILL BE DOWNCAST AND SHIELDED, EXCEPT WHERE NECESSARY FOR PERSONNEL SAFETY.

CAD File: S:\Projects\21010_Oxy_Lighting_Studies\CAD\Electrical\Drawings\Physical Plans\21010-EE-510.dwg
 Plot Date: Wednesday, February 21, 2024 11:09:29 AM Plotted By: Adam Ramirez
 CTB Used: SE_Std_L&W_Full_size.ctb



This document is copyrighted and is an instrument of service by Samuel Engineering (SE). It was prepared solely for the Owner's/Client's use on this project only. Use, copy or disclosure of any information shown, in whole or in part, without SE's consent, is strictly prohibited, is a copyright breach and may be prosecuted. Any unauthorized reuse shall be at the sole risk of the user.

NUMBER	TITLE

NO.	DESCRIPTION	DATE	BY

NO.	DESCRIPTION	DATE	BY

SCALE:	AS NOTED	DATE
DESIGNED:	A. RAMIREZ	02/22/24
DRAWN:	A. RAMIREZ	02/22/24
CHECKED:	L.OHL	02/22/24
PE APPROVED:	R.MORRIS	02/22/24
PM APPROVED:	M. FORTNEY	02/22/24

CLIENT: KERR MCGEE
 PROJECT LOCATION: WELD COUNTY, CO

 8450 E. Crescent Parkway, Suite 200
 Greenwood Village, CO 80111
 Phone: 303.714.4840
 Fax: 303.714.4800
 Web: samuelengineering.com

TITLE
LIGHTING STUDY WELD COUNTY ELECTRICAL LARKSPUR FED PAD PHOTOMETRIC LIGHTING PLAN - PRODUCTION

PROJECT NUMBER
21010
DRAWING NUMBER
21010-EE-510

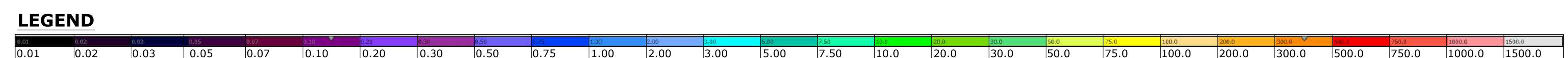
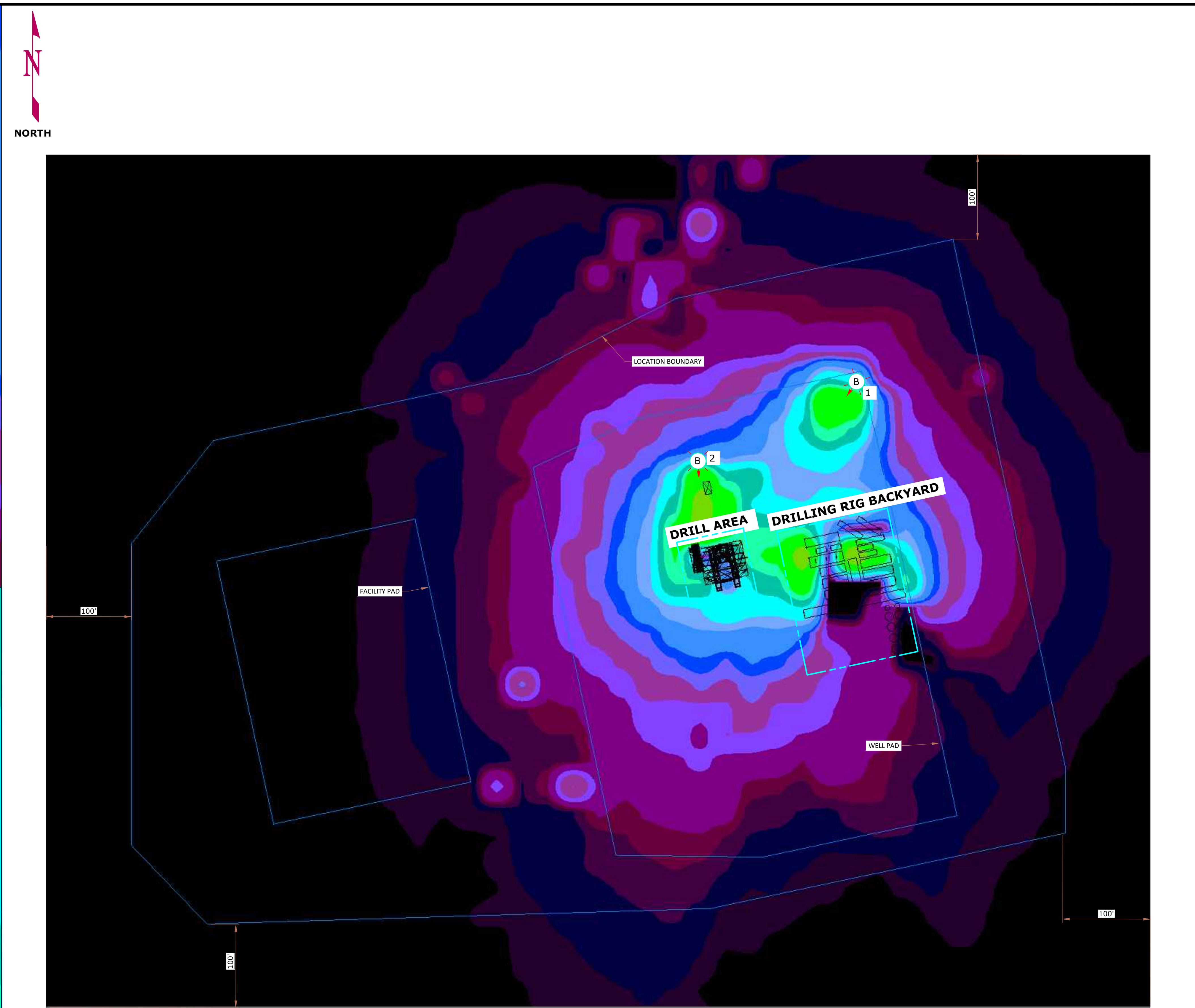
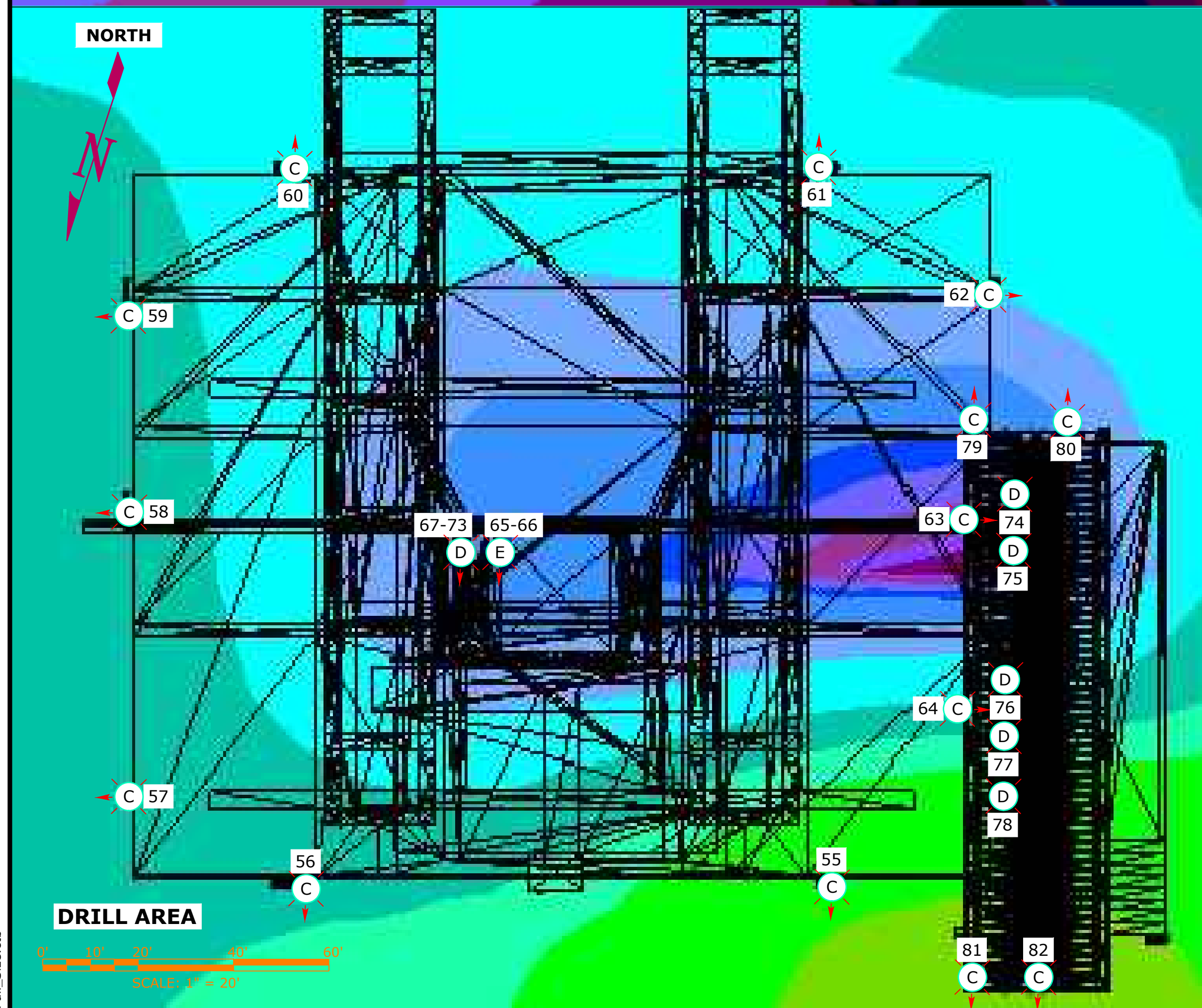
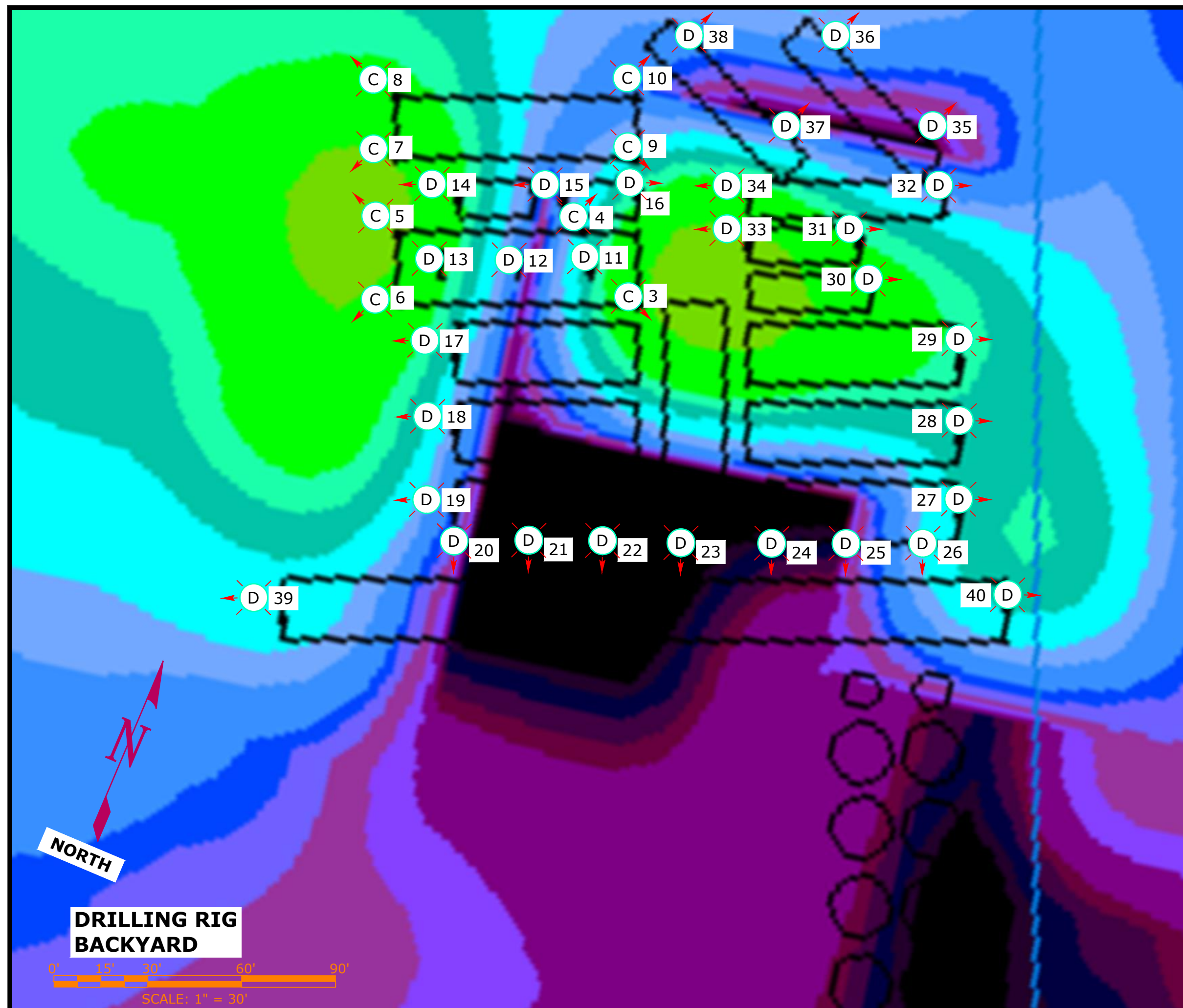
REV. 0



- NOTES:**
1. ALL VALUES IN FOOT-CANDLES (FC).
 2. LIGHTING WILL BE DOWNCAST AND SHIELDED, EXCEPT WHERE NECESSARY FOR PERSONNEL SAFETY.

CAD File: S:\Projects\21010_Oxy_Lighting_Studies\CAD\Electrical\Drawings\Physical Plans\21010-EE-511.dwg
 Plot Date: Wednesday, February 21, 2024 11:12:40 AM. Plotted By: Adam Ramirez
 CTB Used: SE_Std_Color_Full_Size.ctb

This document is copyrighted
 and is an instrument of service
 by Samuel Engineering (SE). It
 was prepared solely for the
 Owner's/Client's use on this
 project only. Use, copy or
 disclosure of any information
 shown, in whole or in part,
 without SE's consent, is strictly
 prohibited, is a copyright breach
 and may be prosecuted. Any
 unauthorized reuse shall be at
 the sole risk of the user.

NUMBER	TITLE

CLIENT	PROJECT MANAGER	PROJECT ENGINEER	CHECK	NO.	DESCRIPTION	DATE	BY

CLIENT	PROJECT MANAGER	PROJECT ENGINEER	CHECK	NO.	DESCRIPTION	DATE	BY

SCALE:	AS NOTED	DATE:	02/22/24
DESIGNED:	A. RAMIREZ	02/22/24	
DRAWN:	A. RAMIREZ	02/22/24	
CHECKED:	L.OHL	02/22/24	
PE APPROVED:	R.MORRIS	02/22/24	
PM APPROVED:	M.FORTNEY	02/22/24	

CLIENT: KERR MCGEE
 PROJECT LOCATION: WELD COUNTY, CO

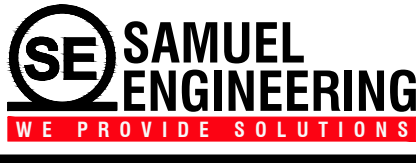

 8450 E. Crescent Parkway, Suite 200
 Greenwood Village, CO 80111
 Phone: 303.714.4840
 Fax: 303.714.4800
 Web: samuelengineering.com

TITLE	PROJECT NUMBER
LIGHTING STUDY WELD COUNTY ELECTRICAL LARKSPUR FED PAD PHOTOMETRIC HEAT MAP - DRILLING	21010
	DRAWING NUMBER
	21010-EE-511

REV.	
0	

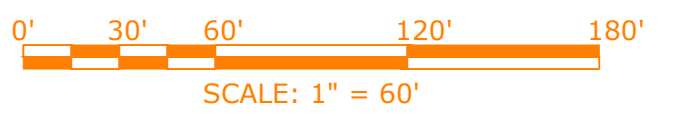
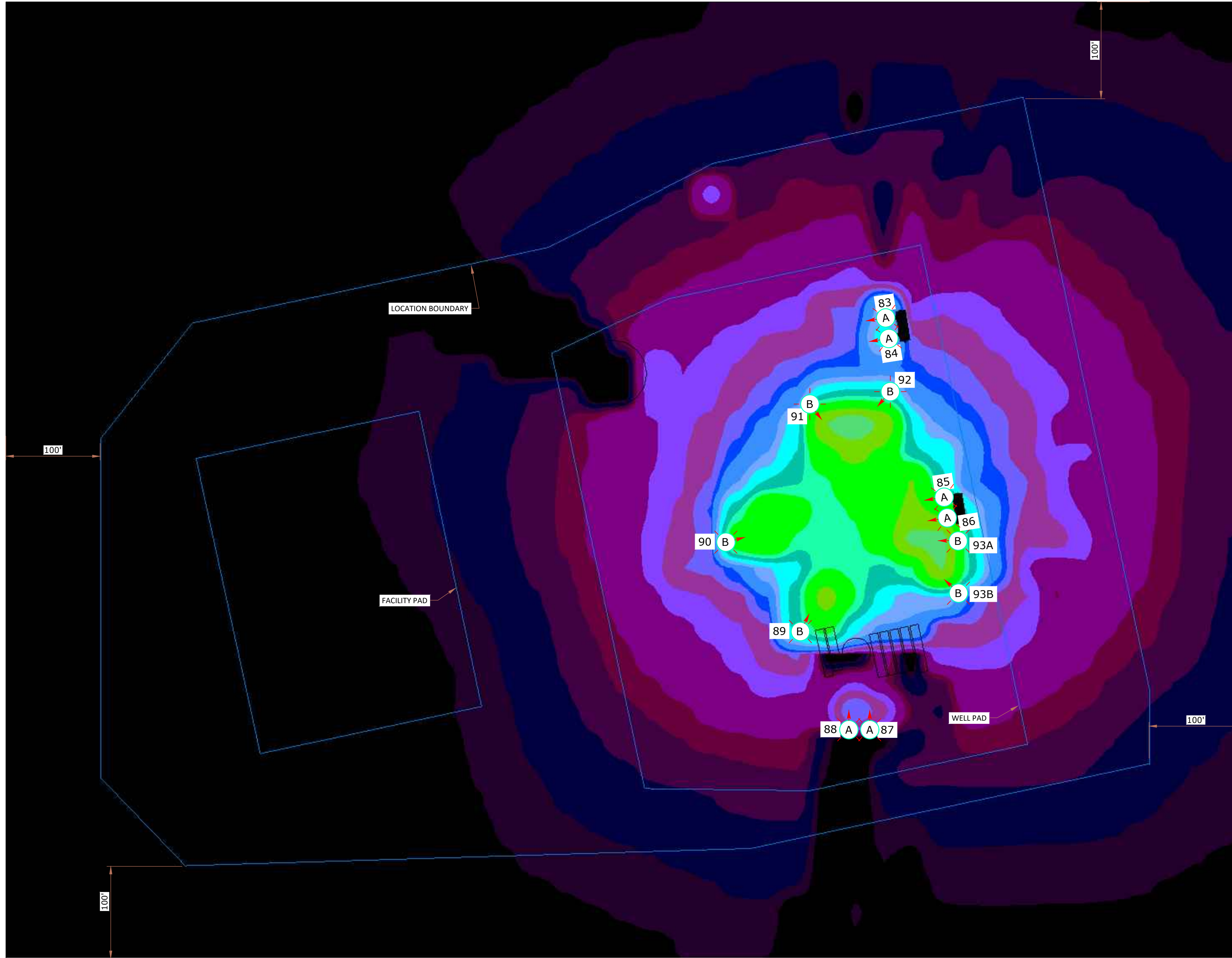

NORTH



NOTES:

1. ALL VALUES IN FOOT-CANDLES (FC).
2. LIGHTING WILL BE DOWNCAST AND SHIELDED, EXCEPT WHERE NECESSARY FOR PERSONNEL SAFETY.

LEGEND



CAD File: S:\Projects\21010_Oxy_Lighting_Studies\CAD\Electrical\Drawings\Physical Plans\21010-EE-512.dwg
 Plot Date: Wednesday, February 21, 2024 11:16:33 AM, Plotted By: Adam Ramirez
 CTB Used: SE_Std_Color_Full_Size.ctb



This document is copyrighted
 and is an instrument of service
 by Samuel Engineering (SE). It
 was prepared solely for the
 Owner's/Client's use on this
 project only. Use, copy or
 disclosure of any information
 shown, in whole or in part,
 without SE's consent, is strictly
 prohibited, is a copyright breach
 and may be prosecuted. Any
 unauthorized reuse shall be at
 the sole risk of the user.

NUMBER	TITLE

CLIENT	PROJECT MANAGER	PROJECT ENGINEER	CHECK	NO.	DESCRIPTION	DATE	BY

CLIENT	PROJECT MANAGER	PROJECT ENGINEER	CHECK	NO.	DESCRIPTION	DATE	BY

SCALE:	AS NOTED	DATE
DESIGNED:	A. RAMIREZ	02/22/24
DRAWN:	A. RAMIREZ	02/22/24
CHECKED:	L.OHL	02/22/24
PE APPROVED:	R.MORRIS	02/22/24
PM APPROVED:	M.FORTNEY	02/22/24

CLIENT: KERR MCGEE
 PROJECT LOCATION: WELD COUNTY, CO

 8450 E. Crescent Parkway, Suite 200
 Greenwood Village, CO 80111
 Phone: 303.714.4840
 Fax: 303.714.4800
 Web: samuelengineering.com

TITLE
LIGHTING STUDY WELD COUNTY ELECTRICAL LARKSPUR FED PAD PHOTOMETRIC HEAT MAP - COMPLETIONS

PROJECT NUMBER
21010
DRAWING NUMBER
21010-EE-512
REV.
0

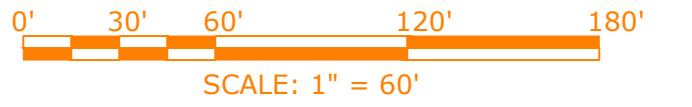
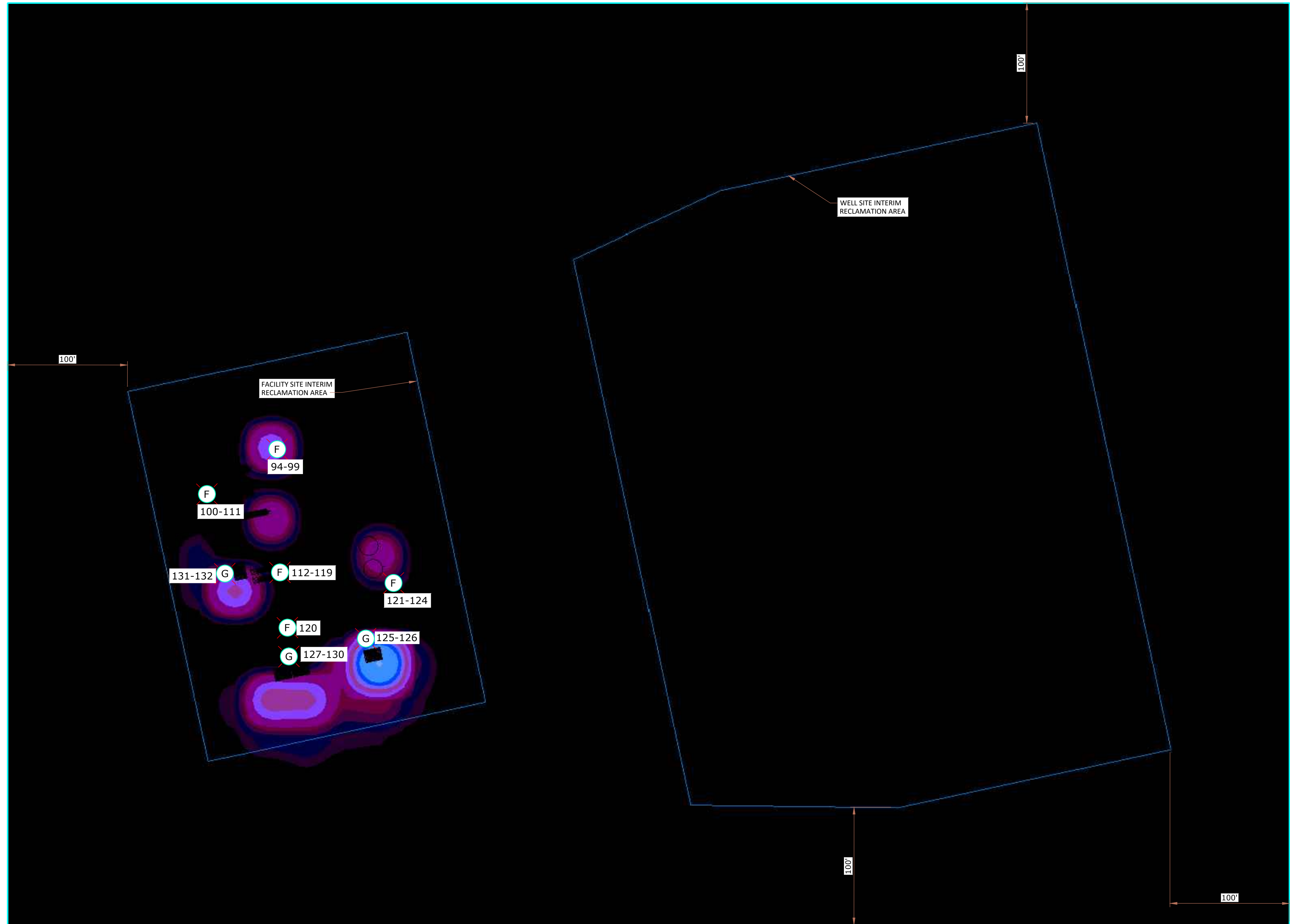

NORTH



NOTES:

1. ALL VALUES IN FOOT-CANDLES (FC).
2. LIGHTING WILL BE DOWNCAST AND SHIELDED, EXCEPT WHERE NECESSARY FOR PERSONNEL SAFETY.

LEGEND

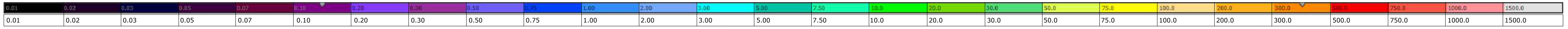

CAD File: S:\Projects\21010_Oxy_Lighting_Studies\CAD\Electrical\Drawings\Physical Plans\21010-EE-513.dwg
 Plot Date: Wednesday, February 21, 2024 11:13:57 AM Plotted By: Adam Ramirez
 CTB Used: SE_Std_Color_Full_Size.ctb



This document is copyrighted and is an instrument of service by Samuel Engineering (SE). It was prepared solely for the Owner's/Client's use on this project only. Use, copy or disclosure of any information shown, in whole or in part, without SE's consent, is strictly prohibited, is a copyright breach and may be prosecuted. Any unauthorized reuse shall be at the sole risk of the user.

NUMBER	TITLE

NO.	DESCRIPTION	DATE	BY

NO.	DESCRIPTION	DATE	BY

SCALE:	AS NOTED	DATE
DESIGNED:	A. RAMIREZ	02/22/24
DRAWN:	A. RAMIREZ	02/22/24
CHECKED:	L.OHL	02/22/24
PE APPROVED:	R.MORRIS	02/22/24
PM APPROVED:	M.FORTNEY	02/22/24

CLIENT: KERR MCGEE
 PROJECT LOCATION: WELD COUNTY, CO

 8450 E. Crescent Parkway, Suite 200
 Greenwood Village, CO 80111
 Phone: 303.714.4840
 Fax: 303.714.4800
 Web: samuelengineering.com

TITLE	PROJECT NUMBER
LIGHTING STUDY WELD COUNTY ELECTRICAL LARKSPUR FED PAD PHOTOMETRIC HEAT MAP - PRODUCTION	21010
	DRAWING NUMBER
	21010-EE-513

REV.	NO.

ATTACHMENT B
FIXTURE CUT SHEETS TYPES A,B,C,D,E,F,G
LIGHTING MITIGATION PLAN
FOR
KERR MCGEE OIL & GAS ONSHORE LP
LARKSPUR FED PAD
Project Number: 21010-40

Fixture Cut Sheet

Type A

Series Spec Sheet

WPS GEN 4

CLASSIC WALL PACK

Selectable color temperature (3 000 K / 4 000 K / 5 000 K)¹

Power selectable¹

Integrated photocell¹

Multi-Voltage (120-347 V)¹

This wall pack series is a classic and familiar design integrated with modern LED technology to promote better energy efficiency and long life. Certain configurations come with integrated photocell, selectable power and/or selectable color temperature. It is best suited for entrances, underpasses or anywhere controlled security lighting is required, the series luminaire is a great addition to any commercial or industrial outdoor wall mount application. The tough die cast aluminum housing is moisture and dustproof. ¹



FEATURES AND SPECIFICATIONS

• Construction

Housing

- This luminaire is made of aluminum die cast and comes standard in a bronze powder coat finish.
- The housing has four conduit entries of 1/2" on each sides and some of the configurations comes with a button type photocell that can be turned off by using the internal switch if needed.¹

Lens

Prismatic tempered glass lens is standard in this product series.

• Electrical

- The drivers allows an input voltage from 120-277 V or 120-347 V AC 50/60 Hz and are 0-10 V dimmable. They are coming with an onboard surge protection:
 - NS29: 2.5kV standard
 - NS40, NS60, NS80, PS40, PS100: 2kV standard
 - NS120: 4kV standard

- This wall pack series is suitable for ambient temperature range of -40°C to +50°C. Available in color temperatures of 4 000 K, 5 000 K or 3CCT selectable (3 000/4 000/5 000 K) with a lumen per watt ratio of 140 lm/W to 152 lm/W depending on the lumen package.
- The color temperature of the fixture is set by default at 4 000 K and can be changed on the field.

• Compliances

- Wet location
- IP65
- Meets requirements of ICES-005 issue 5 for class B products
- cULus
- IK06
- BC Hydro

OVERVIEW

Light source	LED
Watts (W)	25/30/40, 60/80/100 30, 40, 60, 80, 120
Lumens output (lm)	3 625 - 17 885
Efficiency (lm/W)	140 - 152
Color temperature (K)	3CCT (3 000/4 000/5 000) 4 000, 5 000
CRI	> 80

¹ Integrated photocell, multi-volt driver, CCT and Power selectable on some configurations. Consult Quick ship and technical specification table for more details.



quick ship



power selectable¹

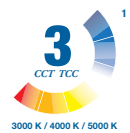

wet location



ICES 005



IK06



Not all products are qualified on the DLC QPL. To view our DLC qualified products, please consult the DLC Qualified Products List at www.designlights.org/search.

QUICK SHIP AND TECHNICAL SPECIFICATION TABLE  ¹

Order code	Model number	DLC unique ID	Watts (W)	Volts (V)	Color temp. (K) ²	Lumen output (lm) ³	Efficiency (lm/W)	Photo-cell ⁶	CRI	Life L70 (hrs) ⁵	Tested hours LM-80 (hrs) ⁵	Calculated TM21 (hrs) ⁵	Finish	Dimming	B.U.G.	LED current (mA)	Power factor	THD (%)	Case qty (master)
------------	--------------	---------------	-----------	-----------	------------------------------	--------------------------------	-------------------	-------------------------	-----	-----------------------------	---------------------------------------	------------------------------------	--------	---------	--------	------------------	--------------	---------	-------------------

Power Select, CCT Select and Integrated Photocell⁶

68314	WPS-PS40-Q-3C	PLW61NEJG50K	25/30/40	120-347	3000/4000/5000	3875/4500/5800 ⁴	141	Yes	>80	54 000	9 000	173 600	Bronze	Yes	B1U3G4	850	≥0.9	≤20	1
68315	WPS-PS100-Q-3C	PLE7PYF9LCSH	60/80/100	120-347	3000/4000/5000	9300/12000/14500 ⁴	137	Yes	>80	54 000	9 000	173 600	Bronze	Yes	B1U3G4	2 100	≥0.9	≤20	1

Single Power, Single CCT and Integrated Photocell⁶

68524	WPS-NS30-W-40K/P127		29	120-277	4 000	4 200	150	Yes	>80	54 000	9 000	173 600	Bronze	Yes	B1U3G5	230	≥0.9	≤20	1
68525	WPS-NS30-W-50K/P127		29	120-277	5 000	4 300	148	Yes	>80	54 000	9 000	173 600	Bronze	Yes	B1U3G5	230	≥0.9	≤20	1

Single Power and Single CCT

68490	WPS-NS40-W-40K	PLVM09BUX07G	40	120-277	4 000	6 004	142	No	>80	54 000	9 000	173 600	Bronze	Yes	B1U3G4	354	≥0.9	≤20	1
68491	WPS-NS40-W-50K	PL3ULW7TEV5H	40	120-277	5 000	6 034	144	No	>80	54 000	9 000	173 600	Bronze	Yes	B1U3G4	354	≥0.9	≤20	1
68492	WPS-NS60-W-40K	PL6EFOU7BPWB	60	120-277	4 000	8 458	146	No	>80	54 000	9 000	173 600	Bronze	Yes	B1U3G5	486	≥0.9	≤20	1
68493	WPS-NS60-W-50K	PL01JETYSQ80	60	120-277	5 000	8 611	147	No	>80	54 000	9 000	173 600	Bronze	Yes	B1U3G5	486	≥0.9	≤20	1
68497	WPS-NS80-W-40K	PLVXL8TOP2UF	80	120-277	4 000	11 242	146	No	>80	54 000	9 000	173 600	Bronze	Yes	B1U4G5	645	≥0.9	≤20	1
68498	WPS-NS80-W-50K	PL2AZJG3LDRQ	80	120-277	5 000	11 446	148	No	>80	54 000	9 000	173 600	Bronze	Yes	B1U4G5	645	≥0.9	≤20	1

Single Power, CCT Select and Integrated Photocell⁶

68316	WPS-NS120-Q-3C	PLYRMZYS3AY3	120	120-347	3000/4000/5000	16 943	137	Yes	>80	54 000	9 000	173 600	Bronze	Yes	B2U4G5	2 600	≥0.9	≤20	1
--------------	----------------	--------------	-----	---------	----------------	--------	-----	-----	-----	--------	-------	---------	--------	-----	--------	-------	------	-----	---

¹ **QUICK SHIP:** Product availability is subject to change without notice. Please contact your Stanpro customer service representative to confirm inventory levels at time of order.

² Typical color temperature range: +/- 5 %.

³ Lumen values are derived from photometric testing. Initial lumens range: +/- 10 %.

⁴ Lumen values are based on 4 000 K default settings. Please refer to Quick ship Technical Specification Table for more details on other color temperatures.

⁵ Life hours are derived from IESNA LM-80-08 testing report and projected per IESNA TM-21-11 extrapolations.

⁶ Integrated ON/OFF photocell that can be easily disabled.

ACCESSORIES (order separately)

Order code	Description
68370	18" Bronze metal backplate
68371	Bronze glare shield
68372	Stainless Steel wireguard



ORDERING GUIDE

Series	Lumen package (W)	Volts (V)	Color temp. (K)	Casting color	Options
WPS	PS40 - 25/30/40 PS100 - 60/80/100 NS120 - 120	Q - 120-347	3C - 3 000/4 000/5 000	BR - Bronze (standard) BK - Black WH - White	KV - 10 kV surge Protection PC - Polycarbonate lens
	NS30 ¹ - 29 NS40 - 40 NS60 - 60 NS80 - 80	W - 120-277	40K - 4 000 50K - 5 000	SP - Special color	KV - 10 kV surge Protection P127 ¹ - Button type photocell 120-277 V PC - Polycarbonate lens

¹ Button type photocell 120-277 V comes standard with the "NS30" lumen package.

Data is based upon tests performed in a controlled environment. Actual performance can vary depending on operating conditions. All products are subject to change or may be discontinued any time without notice.

DIMENSIONS

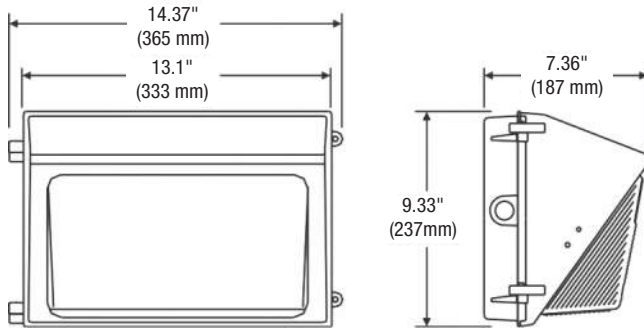

BACKPLATE

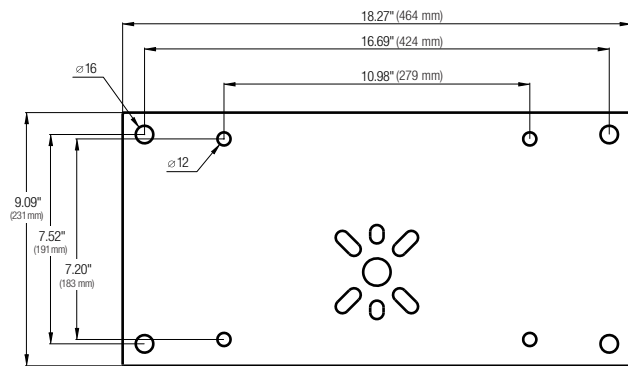

GLARESHIELD

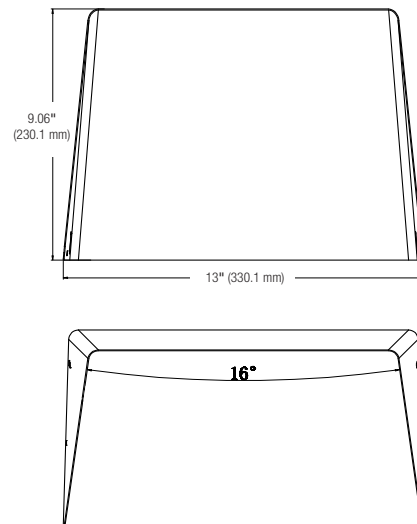

WIREGUARD

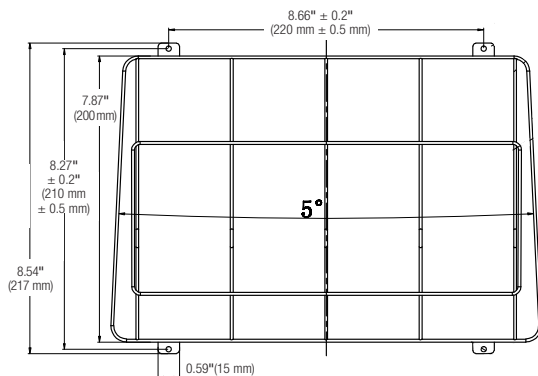

Data is based upon tests performed in a controlled environment. Actual performance can vary depending on operating conditions. All products are subject to change or may be discontinued any time without notice.

LUMINAIRE CLASSIFICATION SYSTEM (LCS) GRAPH

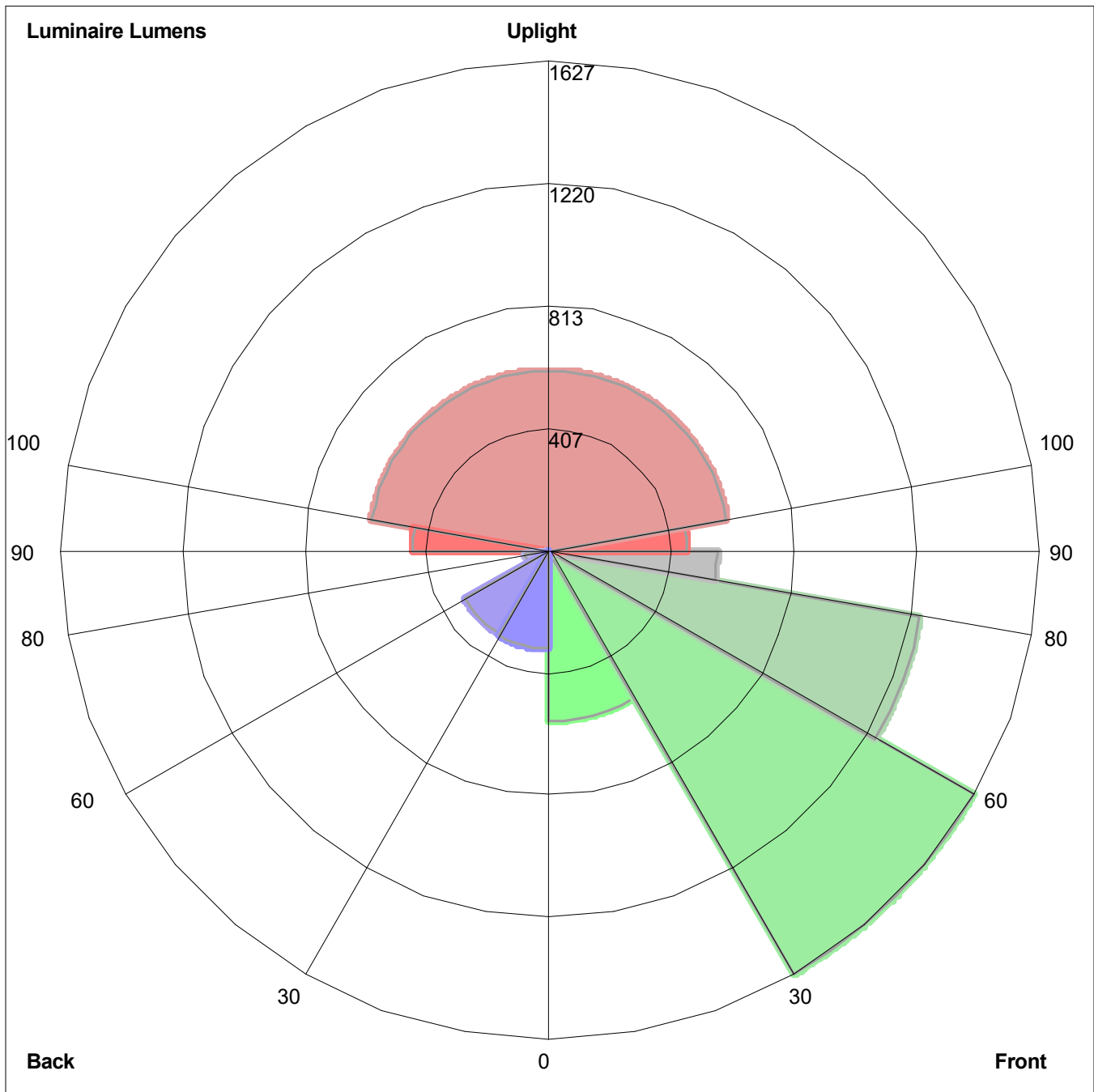

Luminaire Lumens:
Front: Low=566.0, Medium=1626.5, High=1251.8, Very High=558.0
Back: Low=327.7, Medium=323.2, High=79.4, Very High=11.6
Uplight: Low=456.3, High=599.7

BUG Rating : B1-U4-G4

Fixture Cut Sheet

Type B

Example Used



LED Module M8B Series

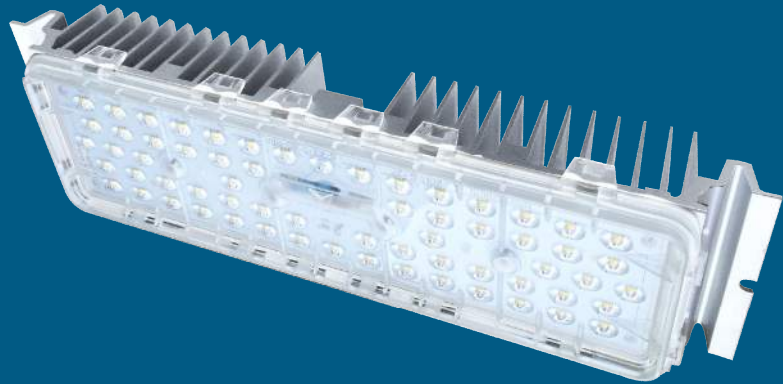

Specification

Working Environment: -40°C~+50°C

Storage Temperature: -40°C~+50°C

Relative humidity: 10%~90%RH

Typical value of pad temperature^[1]: 70°C

IP Rating of LED Light Engine: IP68

Impact Protection Level: IK09

Color Temperature (CCT)^[2]: 3000K, 4000K, 5000K, 5700K

Main Material: Aluminum 6063

Module N.W.: 0.67±0.04 kg

Note :

[1] Typical values of pad temperature is obtained based on 60W with a ambient temperature of 25°C.

[2] Efficacy of 3000K is 5% lower than other CCTs.

Features

- Lumileds Luxeon 3030;
- Super long lifetime(Lumen maintenance);
- Multiple lighting distributions available;
- Wide applicability for complex situations;
- High versatility apply for all sorts of lamps retrofit.

Application

- Street lighting retrofit and application;
- Factory lighting retrofit and application;
- Tunnel lighting retrofit and application;
- Sports lighting retrofit and application.

Ordering Information

For example: M8B-VCA-63 -1321-7040-LU

Module Model	Interface	Dimension of LEDS	Wire Material	LED Qty	Lens Model	Ra & CCT	LED Brand	
M8B	V: V-shape Groove	C: 3030	A: CCC+VDE C: PSE H: UL X: Others	49 49PCS	1324 Type II Short	1325 25 DEG	7030: Ra≥70, 3000K	LU: Lumileds
				63 63PCS	2322 Type II Short (V)	2360 60 DEG	8040: Ra≥80, 4000K	SN: Sanan
					5321 Type II Short	5340 40 DEG	...	XX: Others
					2321 Type II Short	5390 90 DEG		
					1321 Type III Medium	1310 Lambert Type		
					1390 Tunnel Lighting			

Performance

Model	Power (W)	Driving current (mA)	Input voltage (Vdc)	Efficacy (lm/W)	Lumens (lm)
M8B-VCA-63	40	700	48~61	140	5600
M8B-VCA-49	50	1050	38~48	127	6350
M8B-VCA-63	50	860	48~61	135	6750
M8B-VCA-63	60	1050	48~61	127	7620

Note : Values shown are subject to ±5%~±8% tolerance; Cable default A type;

Efficacy above is based on calculated @92% power efficiency ; Light efficacy of 3000K is 5% lower than other CCTs.

Dimensions

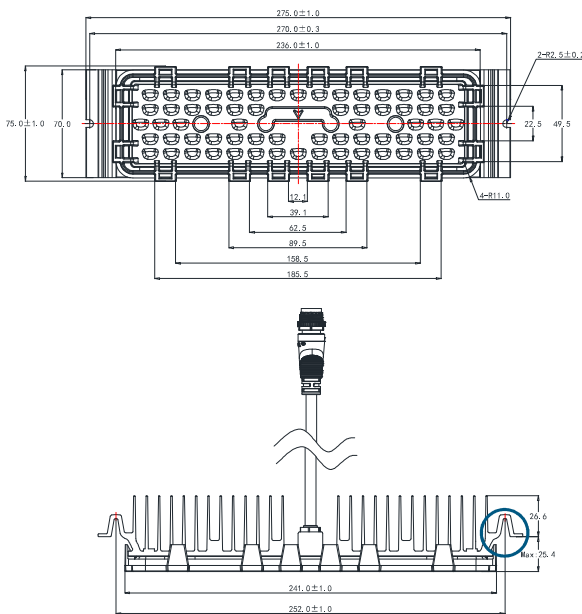

L (mm)	W (mm)	H (mm)
275	75	Max52

The height of the module is the maximum value.

Tolerance: ±0.5mm

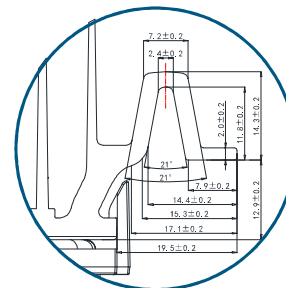

Available Lens Model

1321	1324	1390
1232	2322	5321

Dimensions

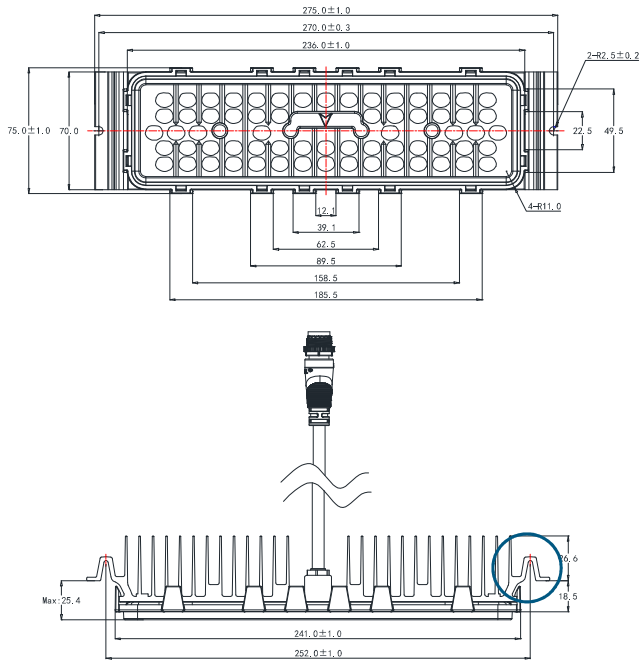

L (mm)	W (mm)	H (mm)
--------	--------	--------

275 75 Max52

The height of the module is the maximum value.

Tolerance: ±0.5mm

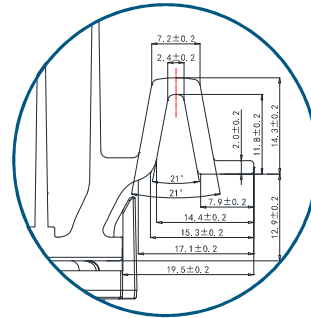

Available Lens Model

1310	1325	5340	2360
5390			

Package Information

L (mm)	W (mm)	H (mm)	Module pcs/carton (PCS)	Package weight (kg)
650	375	190	20	14.9

Values shown are subject to ±5% tolerance.

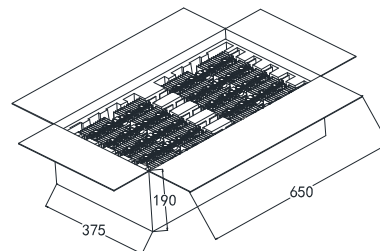
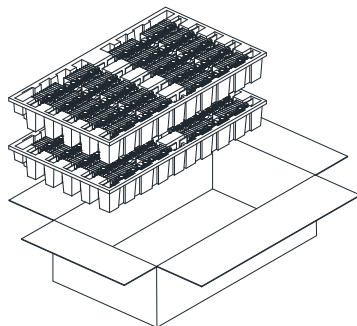

Lighting distributions

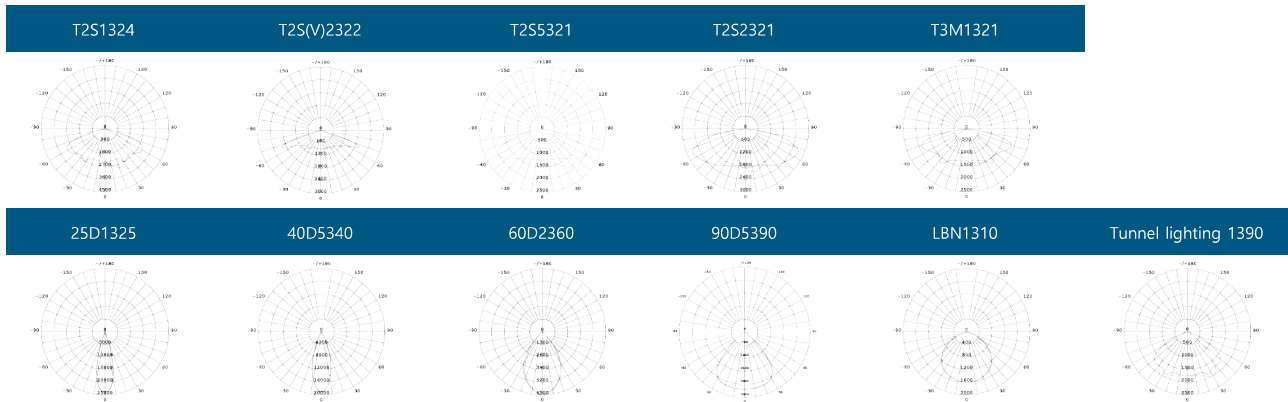

Version History

Change Date	Version	Description of Change		
		Item	From	To
20190905	Ver2.0	Data sheets release (new version) Update of luminous efficacy Optimized G.W of Module package	16.2kgs	14.9kgs

LUMINAIRE CLASSIFICATION SYSTEM (LCS) GRAPH

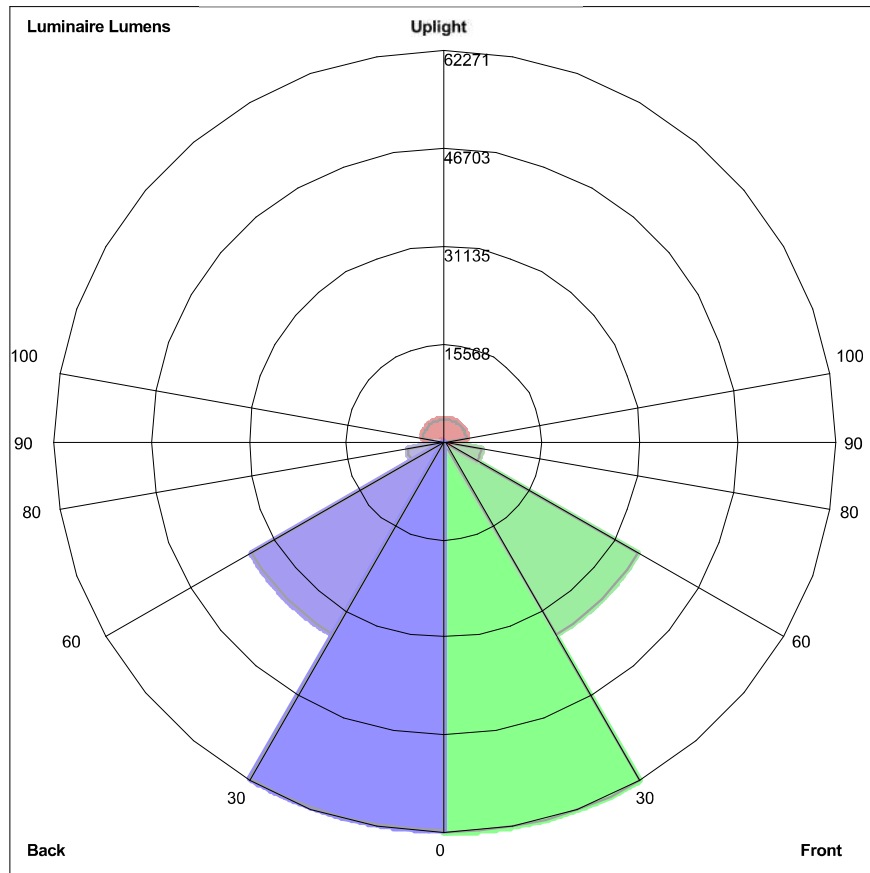

Luminaire Lumens:
Front: Low=62270.6, Medium=35421.7, High=5946.3, Very High= 1328.0
Back: Low= 61920.0, Medium=35466.8, High=5958.8, Very High=1320.7
Uplight: Low=493.0, High=3564.5

BUG Rating : B5-U5-G5

Fixture Cut Sheet

Type C

Pauluhn DFL HID hazardous area floodlights

Cl. I, Div. 2, Groups A, B, C, D
Cl. I, Zone 2, AEx nR II
Cl. II, Div. 1, Groups F, G (250W
max.)
Ex nR II

Marine & Wet Locations
NEMA 4X
IP66

6L

Applications:

- Onshore drilling and exploration
- Pipeline compressor and storage
- Corrosive environments
- Façade security lighting

Features:

- 150-400W high pressure sodium or 175-400W metal halide
- AEx nR, Ex nR restricted breathing rating is standard – restricted breathing offers cooler T-numbers for increased hazardous locations suitability
- NEMA 7x6 butterfly beam floodlight pattern – wide, uniform and far reaching to provide excellent efficiency and more light where you need it
- NEMA Type 4X and IP66 heavy duty, die cast copper-free aluminum construction is designed for use indoors and outdoors in marine and wet locations with stainless steel external hardware suitable for saltwater and corrosive applications
- 40°C, 55°C and 65°C ambient suitability – addresses high ambient common at industrial facilities
- Low ambient capability to -40°C – perfect for colder climates
- Hinged door frame assembly – has captive cover screws for ease of relamping
- Yoke mount design – standard construction provides the greatest mounting flexibility; can be mounted vertically (wall), horizontally (rooftop or floor) or any angle in between
- 3-axis resonance withstand and UL844 vibration compliant – can stand up to the tough jobs
- Precision formed aluminum reflector – superior beam control, distribution and efficiency
- High light output with a low cost of operation – cost-effectiveness in a high wattage floodlight
- Slipfitter adapter for pole mounting and wall mounting bracket available

Certifications and compliances:

- Class I, Division 2, Groups A, B, C, D
- Class I, Zone 2, AEx nR II
- Class II, Division 1, Groups F, G (250W maximum)
- Ex nR II
- UL/cUL844 – Hazardous Locations
- UL/cUL1598 – Luminaires
- UL/cUL1598A – Supplemental Requirements for Luminaires for Installation on Marine Vessels
- 60079-15
- NEMA Type 4X
- IP66
- Marine and wet locations
- ABS



Standard materials and finishes:

- Housing and lens frame – heavy duty die cast copper-free aluminum with Corro-free epoxy powder coat finish
- Lens – heat- and impact-resistant tempered glass
- Gasket – one-piece silicone
- Mounting brackets – aluminum with Corro-free epoxy powder coat finish
- Reflector – precision formed aluminum
- Lamp holder – porcelain
- Hardware – stainless steel

Technical specifications:

- Entries – one 3/4" AEx/Ex gland
- Wind rating – EPA: 2.90 at vertical
- Lamp type – high pressure sodium; probe start metal halide^A; pulse start metal halide (lamps not provided)
- Lamp holder – mogul base
- Ballast – multi-tap 120/208/240/277V, 60 Hz (standard); 220-240V, 50 Hz (optional); tri-tap 120/277/347V (optional); 480V (optional)

Mounting option:

- Yoke mount

Photometrics:

- Complete photometrics can be found at www.crouse-hinds.com/photometrics

^A Not available in the U.S.

Pauluhn DFL HID hazardous area floodlights

Cl. I, Div. 2, Groups A, B, C, D
Cl. I, Zone 2, AEx nR II
Cl. II, Div. 1, Groups F, G (250W max.)
Ex nR II

Marine & Wet Locations
NEMA 4X
IP66

6L

Options:

Description	Suffix
• Lamps included	L ⓐ
• 480V.....	480
<i>Replace /MT in catalog number with /480</i>	
• 230V.....	230
<i>Replace /220 ONLY in catalog number with /230</i>	

Accessories (ordered separately):

Description	Cat. #
• Pole mount slipfitter adapter.....	SFA6
• Wall mount bracket adapter.....	SWB6
• Bull horn, 2 tenon, gray.....	BLHN2
• Bull horn, 3 tenon, gray.....	BLHN3

Ordering information:

Cat. #	Lamp type	Watts	Weight (lbs.)	ANSI lamp type	Zone T-code	Division T-code	Ambient temperature °C	Supply wire °C
DFLMY250/MT 76 S828	Pulse start metal halide	250	42.0	M153	T3	T1	40/55/65	90/90/105
DFLMY400/MT 76 S828	Pulse start metal halide	400	44.0	M155	T3	T1	40/55	105/105
DFLMY320/MT 76 S828	Pulse start metal halide	320	44.0	M154	T3	T1	40/55	105/105
DFLMY250/TT 76 ⓐ	Probe start metal halide	250	42.0	M58 ⓐ	T3	T1	40/55/65	90/90/105
DFLMY400/TT 76 ⓐ	Probe start metal halide	400	44.0	M59 ⓐ	T3	T1	40/55	90/105
DFLMY250/220 50 76 ⓐ	Probe start metal halide	250	42.0	M58 ⓐ	T3	T1	40/55/65	90/90/105
DFLMY400/220 50 76 ⓐ	Probe start metal halide	400	44.0	M59 ⓐ	T3	T1	40/55	90/105
DFLSY250/MT 76	High pressure sodium	250	40.0	S50	T3	T1	40/55/65	90/90/105
DFLSY400/MT 76	High pressure sodium	400	44.0	S51	T3	T1	40/55	90/105
DFLSY250/TT 76	High pressure sodium	250	40.0	S50	T3	T1	40/55/65	90/90/105
DFLSY400/TT 76	High pressure sodium	400	44.0	S51	T3	T1	40/55	90/105
DFLSY250/220 50 76	High pressure sodium	250	40.0	S50	T3	T1	40/55/65	90/90/105
DFLSY400/220 50 76	High pressure sodium	400	44.0	S51	T3	T1	40/55	90/105

Dimensions (in inches):

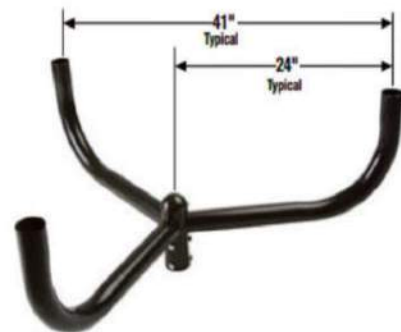
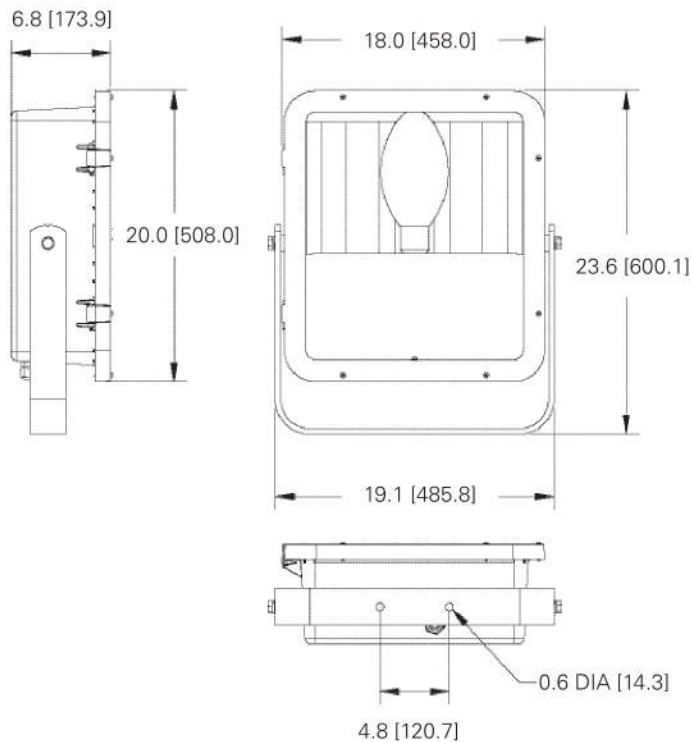

Bull horns – provided with 2 3/8" pole tenon

ⓐ Lamp is not included unless option 'L' is selected.
ⓐ Not available in the U.S.



6L

Pauluhn DFL HID hazardous area floodlight

The image below was obtained from the manufacturer's IES file of the fixture. It is included to show the lumen value of the fixture, which is not included in the manufacturer catalog cutsheet.

Active luminaire

CAST ALUMINUM HOUSING, FORMED SPECULAR HAMMERTONE REFLECTOR, CLEAR GLASS ENCSLOURE.
DFLMYM400



0.813 x 1.240 x 0.328ft

Luminaire type index

Designation in DWG plan

Select ▶

Properties

Name

Positioning

Position ft

Rotation °

Mounting type

Mounting type

Light centre height ft

Mounting height ft

▼ Photometric data

Luminaire luminous flux lm

Light output ratio %

Connected load W

Luminous efficacy lm / W

LUMINAIRE CLASSIFICATION SYSTEM (LCS) GRAPH

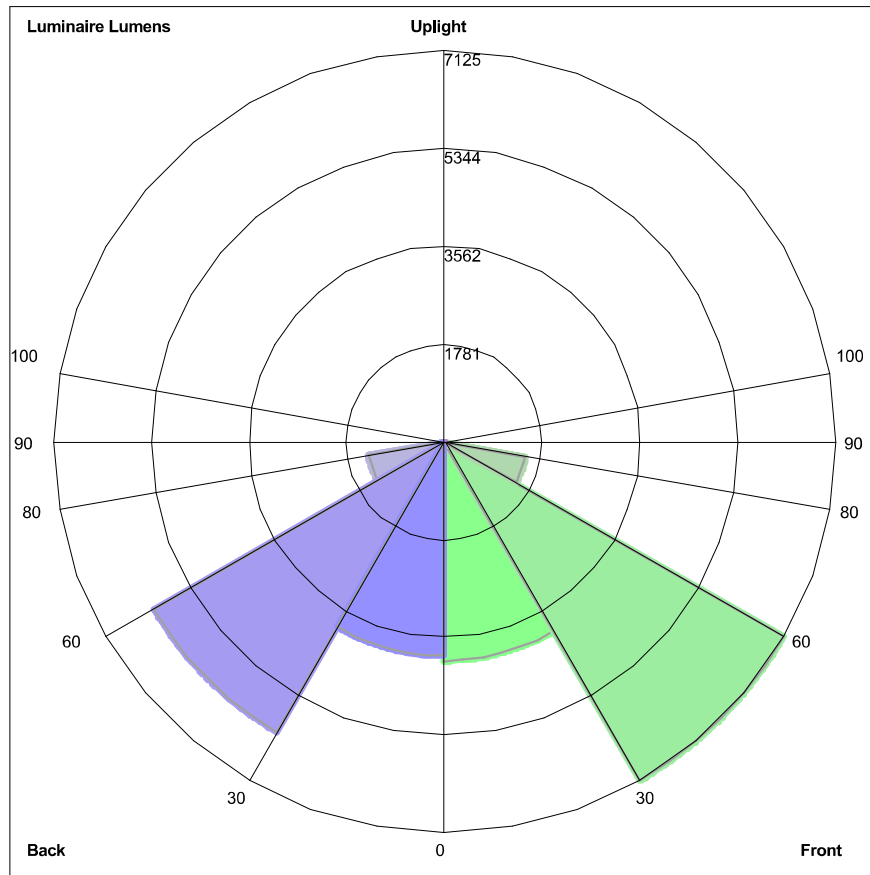

Luminaire Lumens:
Front: Low=3985.6, Medium= 7125.0, High=1500.3, Very High=28.6
Back: Low=3894.8, Medium=6102.1, High=1404.5, Very High=40.2
Uplight: Low=0.0, High=0.0

BUG Rating : B4-U0-G3

Fixture Cut Sheet

Type D

Pauluhn DLL LED Luminaires

For land-based drilling

Cl. I, Div. 2, Groups A, B, C, D
Cl. I, Zone 2
Cl. II, Div. 2, Groups F, G
Cl. III

UL Listed
CSA Certified
Marine & Wet Locations
NEMA 4X; IP66

2L

2L

The Pauluhn™ DLL linear LED is specifically designed to replace fluorescent T12, T8 and T5HO lighting on land-based and offshore drilling platforms. The rugged and durable design features the industry's most versatile and flexible mounting options. The Pauluhn DLL is the ideal solution for high vibration, impact and hose down in drilling applications.

Model	Typical lumens	Watts	Lumens per watt	Equivalent HID luminaire	Typical energy savings / lifetime
DLL2	3,958	32	124	T12HO	Up to 63%
				T8HO	Up to 59%
				T5HO	Up to 47%
				T12	Up to 36%
				T8	Up to 25%
DLL4	7,900	63	130	T5	Up to 9%
				T12HO	Up to 58%
				T8HO	Up to 54%
				T5HO	Up to 43%
				T12	Up to 37%
				T8	Up to 22%
				T5	Up to 10%

Applications:

- Land-based and offshore rigs; areas include: derrick, mast, SCR house, top drive, operator's house, power and pump stations

Features:

- High efficacy: up to 120 LPW
- 40°C to +65°C ambient operating temperature (standard model)
- Low profile (<3" height)
- Versatile ceiling/swivel, wall, flush, pole and pendant mounting options
- Wide and narrow optics for uniform illumination in control room and drill mast
- Four points of secondary retention
- 2,000 PSI high pressure hose rated
- High vibration resistance
- Emergency battery back-up (90 minutes) and surge protection options (up to 10 kV)Ⓐ
- DesignLights Consortium® Qualified (some models are not DLC qualified)Ⓑ
- 5 year fixture warranty

Standard materials:

- Housing – copper-free aluminum; Corro-free epoxy powder coat (optional)
- Lens – clear polycarbonate; diffused polycarbonate

Photometrics:

- Complete photometrics can be found at www.crouse-hinds.com/photometrics

Temperature performance data:

Ambient temp. °C	Min. temp. supply wire °C	Simultaneous rating		
		Class I, Div. 2	Class II, Div. 2	Class I, Div. 2; Class II, Div. 2
40	60	T6	T6	T6
55	75	T5	T5	T5
65	90	T5	T5	T5



Mounting (ordered separately):

Versatile mounting options:

- Flush back mount
- Swivel/ceiling back mount
- Offset ceiling mount
- Offset wall mount
- Pole mount
- Pendant mount

Easily retrofit to:

- Existing Pauluhn DuraPro and MagnaPro fluorescent light fixtures
- Rig-A-Lite and Snelson C1D2 fluorescent lighting fixtures

Certifications and compliances:

NEC:

- Class I, Division 2, Groups A, B, C, D
- Class I, Zone 2
- Class II, Division 2, Groups F, G
- Class III
- NEMA 4X, IP66
- Marine and wet locations

UL standards:

- UL844 – Electrical Fixture Hangers for Hazardous Locations
- UL1598 – Luminaire
- UL1598A – Luminaire for Installation on Marine Vessels
- UL924 – Emergency Lighting

CSA standard:

- C22.2 No. 137

Additional certifications:

- ABS design assessed

Electrical ratings:

	DLL2	DLL4
Lumen output	3,958	7,900
Frequency	50/60 Hz	50/60 Hz
Voltage	100-277 VAC, 108-250 VDC; 347-480 VAC	

Model	Voltage	Current (A)	Watts	Power factor	THD
DLL2/UNV1	100	0.33	32.5	0.92	<20%
DLL2/UNV1	277	0.13	34.3	0.92	<20%
DLL2/UNV34	347	0.10	32.2	0.92	<20%
DLL2/UNV34	480	0.07	34.5	0.92	<20%
DLL4/UNV1	100	0.63	63.4	0.92	<20%
DLL4/UNV1	277	0.23	62.5	0.92	<20%
DLL4/UNV34	347	0.18	61.4	0.92	<20%
DLL4/UNV34	480	0.13	63.9	0.92	<20%

Weights:

Model	Lbs.	Kg.
DLL2	12.50	5.70
DLL4	22.50	10.20

Ⓐ One year warranty.

Ⓑ Refer to www.designlights.org Qualified Products List under Family Models for full listing details. Not all models are approved for all application categories.

Pauluhn DLL LED luminaires

For land-based drilling

Cl. I, Div. 2, Groups A, B, C, D
Cl. I, Zone 2
Cl. II, Div. 2, Groups F, G
Cl. III

UL Listed
CSA Certified
Marine & Wet Locations
NEMA 4X; IP66

2L

Designed for drilling. Pauluhn DLL linear LED luminaires are engineered to handle demanding conditions faced on land-based drilling rigs. The DLL stands up to high vibration, hose down, shock and impact, while delivering long life and high lumen performance for up to 20 years.

Custom optics:

- Standard wide (120°) beam spread for control room and indoor application maximizes illumination on wall panels
- Narrow (80°) beam spread option for high mast/derrick application avoids spillage and light loss

Comprehensive certification:

- Single model certified for use in Class I, Division 2 and Class II, Division 2 harsh and hazardous applications

Quick & easy installation:

- Easy access to drivers and wiring
- No custom brackets or hardware needed
- Seven mounting options available
- Easily retrofit to Pauluhn DuraPro and MagnaPro, Rig-A-Lite and Snelson



Slim profile:

- 2.7" fixture height (excluding mounting brackets)
- Perfect for mounting in confined or low height areas

Built to last:

- Ingress protection from hose down water or diesel fuel in harsh operational conditions – passed 2,000 PSI high pressure test
- Vibration-, impact- and shock-resistant – passed 5G, 3-axis vibration test
- 60,000 hour lifetime at 55°C ambient



Pauluhn DLL LED luminaires

For land-based drilling

Cl. I, Div. 2, Groups A, B, C, D
Cl. I, Zone 2
Cl. II, Div. 2, Groups F, G
Cl. III

UL Listed
CSA Certified
Marine & Wet Locations
NEMA 4X; IP66

2L

2L

Ordering information:

Part number example

DLL4N/UNV1 S903 TF P EM1

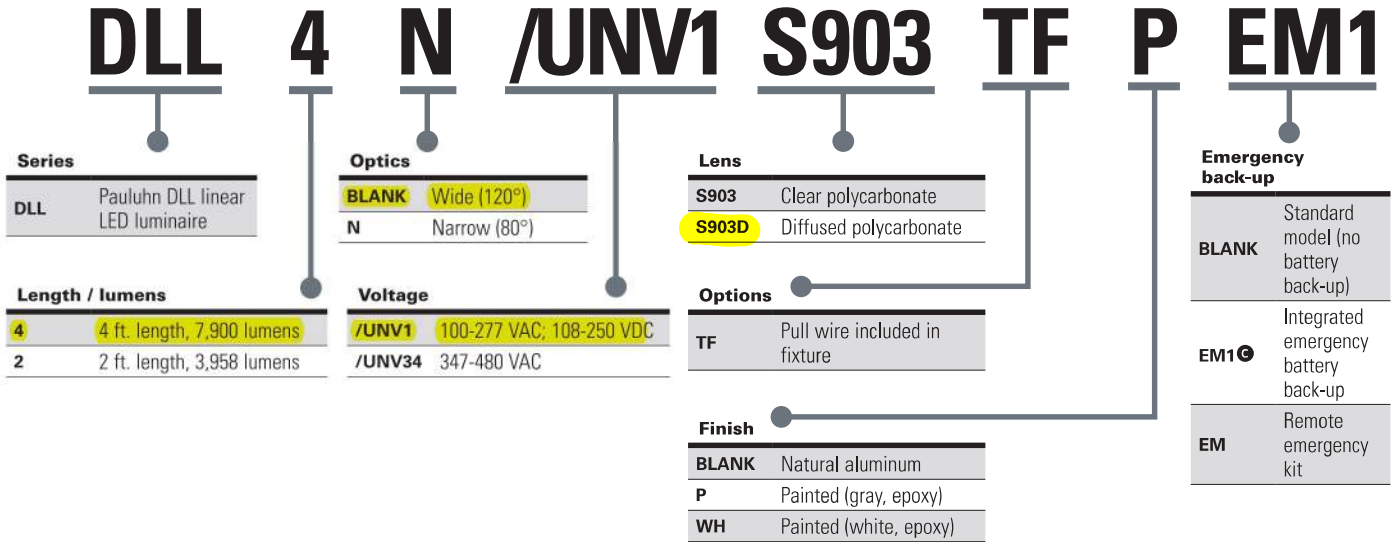

Accessories (ordered separately):

Description	Cat. #	Description	Cat. #
• Flush/back mount back plate.....	DP1057MTK <i>Compatible with DuraPro</i>	• Pendant mount kit.....	PEND HAZ KIT
• Ceiling/swivel mount.....	DP1050MTK <i>Compatible with DuraPro</i>	• Safety chain kit.....	SS KIT
• Ceiling/wall mount offset.....	DP1053MTK <i>Compatible with DuraPro</i>	• 1 amp driver replacement kit, 100-277 VAC for 4 ft. linear.....	VMVL/UNV1 80W 1A KIT
• Ceiling mount bracket and adapter kit.....	MP1054MTK KIT <i>Compatible with MagnaPro</i>	• 1 amp driver replacement kit, 347-480 VAC for 4 ft. linear.....	VMVL/UNV34 80W 1A KIT
• Offset wall mount.....	DP1052MTK <i>Compatible with DuraPro</i>	• 0.5 amp driver replacement kit, 100-277 VAC for 2 ft. linear.....	VMVL/UNV1 80W 0.5A KIT
• Pole mount kit, 1.25" conduit.....	PM KIT 1.25	• 0.5 amp driver replacement kit, 347-480 VAC for 2 ft. linear.....	VMVL/UNV34 80W 0.5A KIT
• Pole mount kit, 1.50" conduit.....	PM KIT 1.5		
• Pole mount kit, 2.00" conduit.....	PM KIT 2.0		

Dimensions and mounting options:

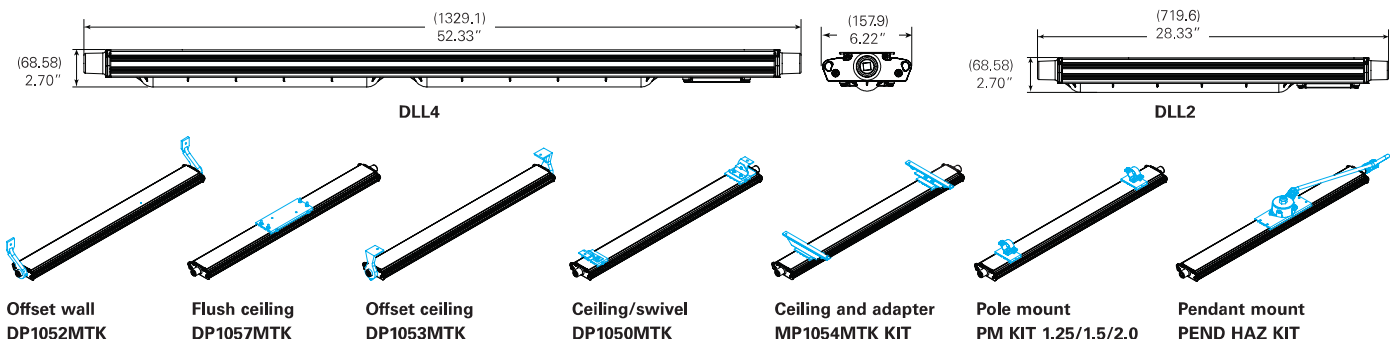

One year warranty. Remote EM kit also available, 120-277 VAC only. Available with 4 ft. model only.

Pauluhn DLL LED Luminaires

For land-based drilling

Cl. I, Div. 2, Groups A, B, C, D
Cl. I, Zone 2
Cl. II, Div. 2, Groups F, G
Cl. III

UL Listed
CSA Certified
Marine & Wet Locations
NEMA 4X; IP66

2L

Mounting options:

Ceiling/swivel mount DP1050MTK

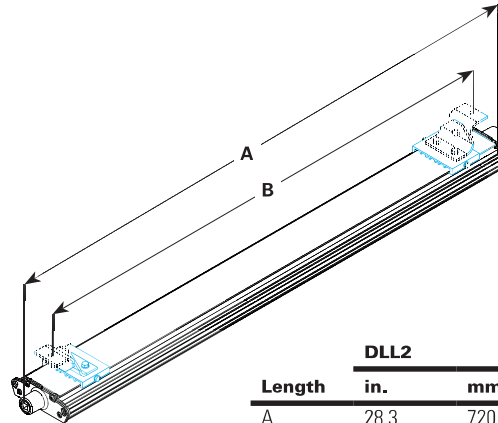
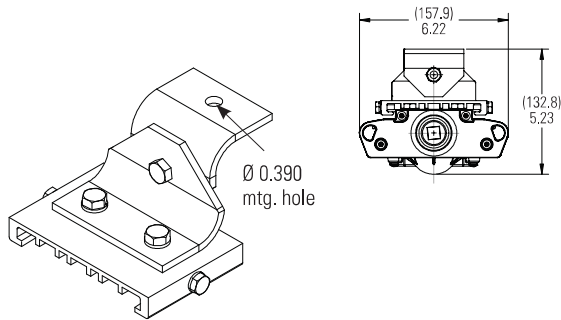

Length	DLL2		DLL4	
	in.	mm.	in.	mm.
A	28.3	720	52.3	1329
B	9-27	222-681	9-51	222-1289

Pole mount PM KIT 1.25/1.5/2.0

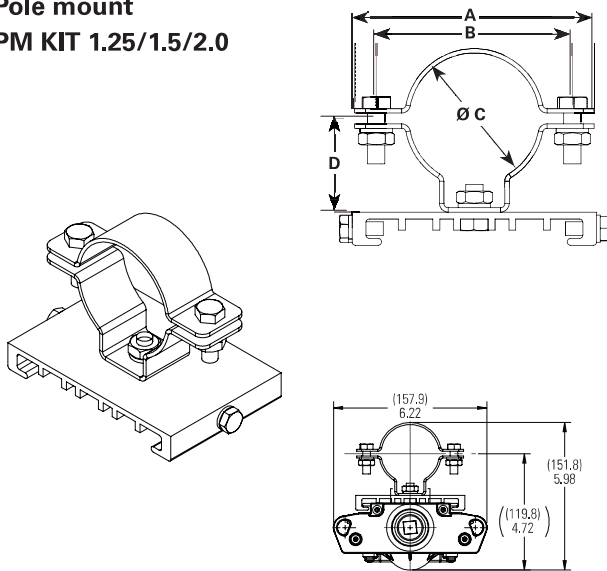

Configuration	ALL MEASUREMENTS IN INCHES			
	A	B	C	D
PM KIT 1.25	4.331	3.543	1.680	1.693
PM KIT 1.5	3.740	2.953	2.000	1.535
PM KIT 2.0	3.386	2.598	2.360	1.378

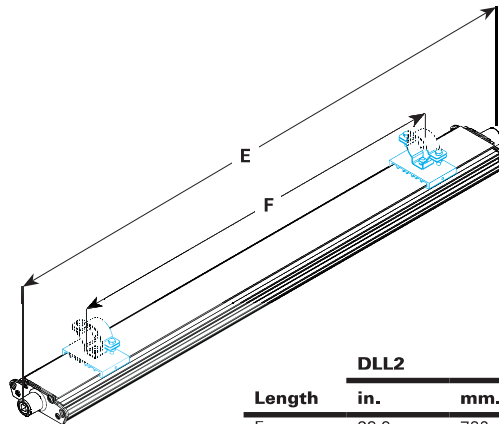

Length	DLL2		DLL4	
	in.	mm.	in.	mm.
E	28.3	720	52.3	1329
F	12-21	305-533	24-45	610-1143

MagnaPro mount MP1054MTK KIT

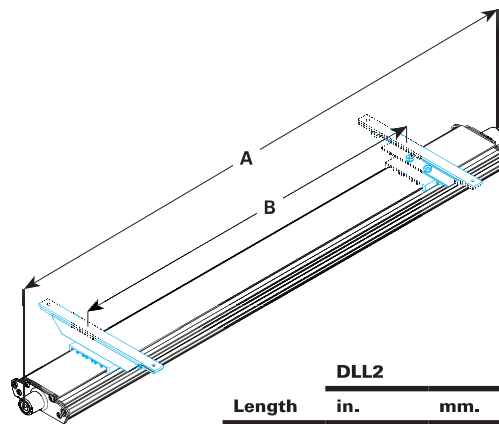
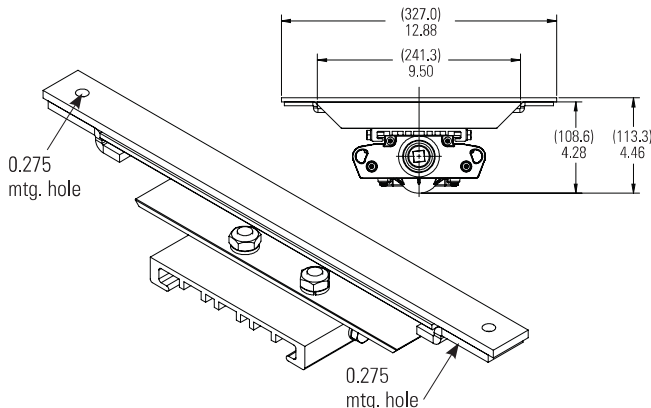

Length	DLL2		DLL4	
	in.	mm.	in.	mm.
A	28.3	720	52.3	1329
B	12-22	305-559	24-46	610-1168

Pauluhn DLL LED luminaires

For land-based drilling

Cl. I, Div. 2, Groups A, B, C, D
Cl. I, Zone 2
Cl. II, Div. 2, Groups F, G
Cl. III

UL Listed
CSA Certified
Marine & Wet Locations
NEMA 4X; IP66

2L

2L

Mounting options (continued):

Offset wall DP1052MTK

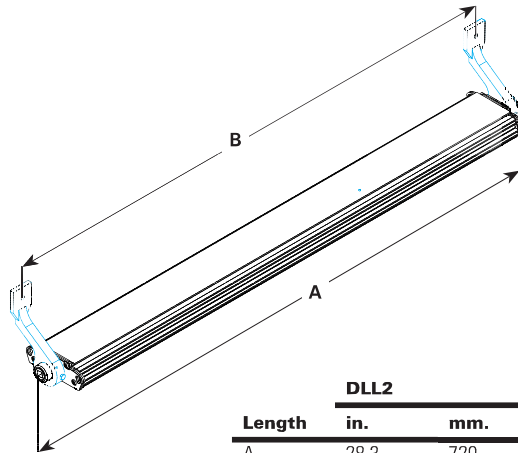
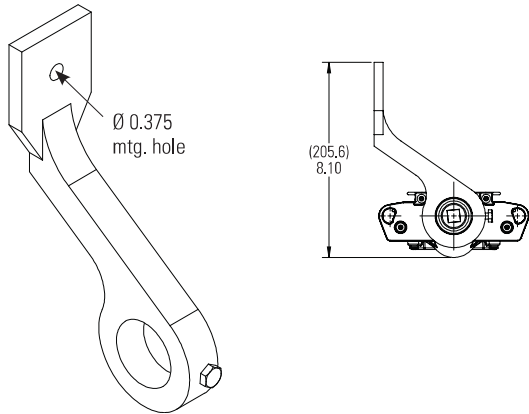

Length	DLL2		DLL4	
	in.	mm.	in.	mm.
A	28.3	720	52.3	1329
B	26.3	669	50.3	1278

Offset ceiling/wall mount DP1053MTK

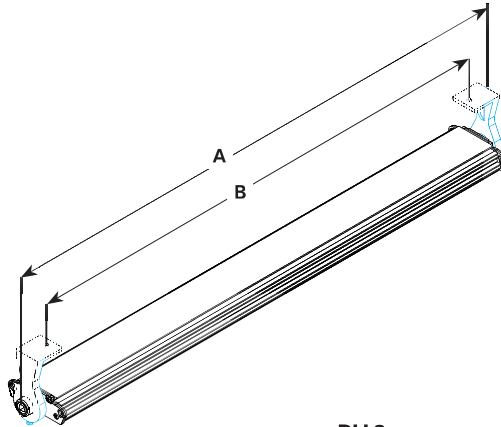
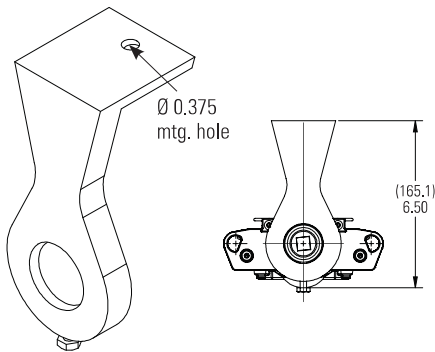

Length	DLL2		DLL4	
	in.	mm.	in.	mm.
A	28.3	720	52.3	1329
B	26.3	584	47.0	1194

Flush ceiling DP1057MTK

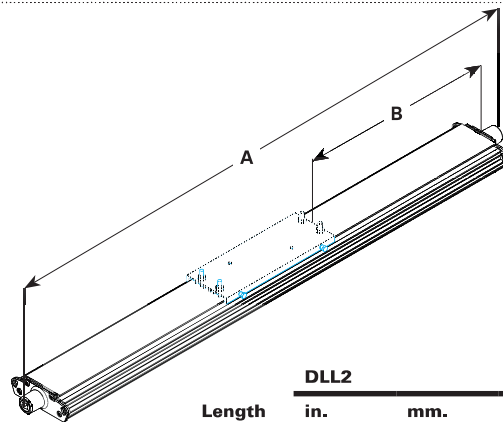
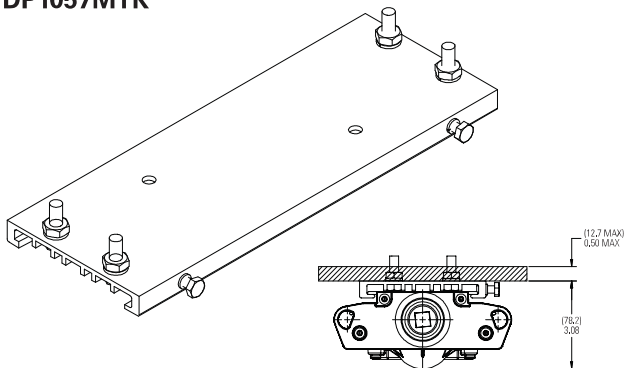

Length	DLL2		DLL4	
	in.	mm.	in.	mm.
A	28.3	720.0	52.3	1329.0
B	6.2	157.5	18.2	462.0

Pauluhn DLL LED luminaires

For land-based drilling

Cl. I, Div. 2, Groups A, B, C, D
Cl. I, Zone 2
Cl. II, Div. 2, Groups F, G
Cl. III

UL Listed
CSA Certified
Marine & Wet Locations
NEMA 4X; IP66

2L

2L

Mounting options (continued):

Pendant mount – Class I, Division 2 only
PEND HAZ KIT

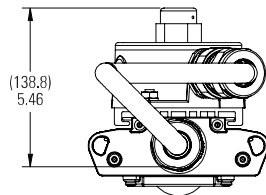
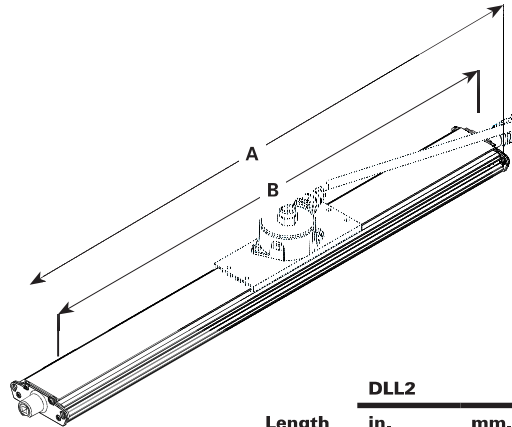
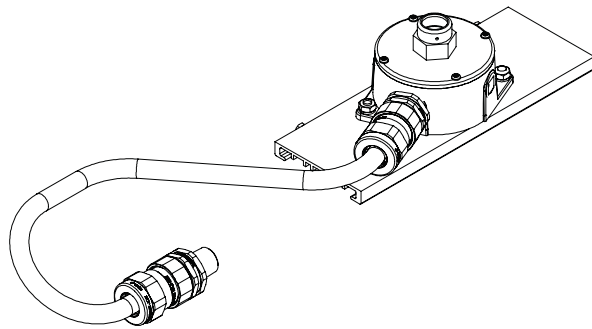

Length	DLL2		DLL4	
	in.	mm.	in.	mm.
A	31.7	805	55.8	1418
B	28.3	720	52.3	1329
C	4.2	108	16.0	406
D	12.2	310	24.0	610
E	34.9	886	58.9	1495

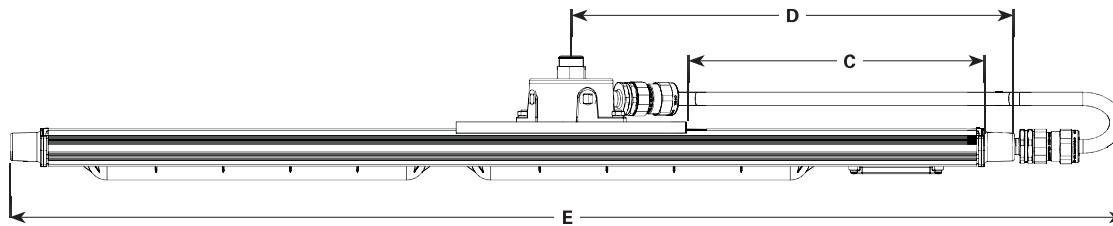

Pauluhn DLL LED luminaires

Integral battery back-up

Cl. I, Div. 2, Groups A, B, C, D
Cl. II, Div. 2, Groups F, G

UL Listed
CSA Certified
Wet Locations
Type 4X; IP66

2L

2L

Pauluhn DLL linear LED luminaires are available with an integral battery back-up module. Virtually the same size as the standard 4 foot model and 90 minutes of emergency lighting to keep your facility and personnel safe.



Model	EM output	Normal output
DLL4/UNV1 S903 EM1	1,400 lumens (100-277V)	6,720 lumens (100-277V)

Applications:

- Egress and emergency lighting for areas requiring uninterrupted lighting during power failure
- Hazardous rated indoor and outdoor emergency lighting in manufacturing plants, heavy industrial, chemical and petrochemical facilities, platforms, loading docks and parking areas

Features:

- Operating ambient: 0°C to +40°C
- 90-minute run time in emergency mode
- 6,720 lumen output for normal operation; 1,400 lumen output in emergency mode
- 50,000 hours rated life at 40°C
- IP66 rated enclosure
- LED indicator to check battery operation
- Nickel cadmium battery
- 1 year warranty

Certifications and compliances:

NEC/CEC:

- Class I, Division 2, Groups A, B, C, D
- Class II, Division 2, Groups F, G
- Wet locations, Type 4X, IP66

UL standards:

- UL844 – Hazardous (Classified)
- UL1598 – Luminaires
- UL1598A – Marine
- UL924 – Emergency Lighting

CSA standard:

- CSA C22.2 Nos. 137, 141

Electrical ratings:

	EM output	Normal output
Voltage	120	277
Amperage at 120 VAC	0.480	0.212
Wattage at 120 VAC	57.8	57.7
Lumen output	1,400	6,720
Frequency	50/60 Hz	50/60 Hz
Power factor at 100 VAC	>0.90	>0.90
THD	6.58	11.70

Temperature performance data:

Ambient temp. °C	Min. temp. supply wire °C	Simultaneous rating		
		Class I, Div. 2	Class II, Div. 2	Class I, Div. 2; Class II, Div. 2
40	60	T5	T6	T5

Photometrics:

- Complete photometrics can be found at www.crouse-hinds.com/photometrics

Dimensions:

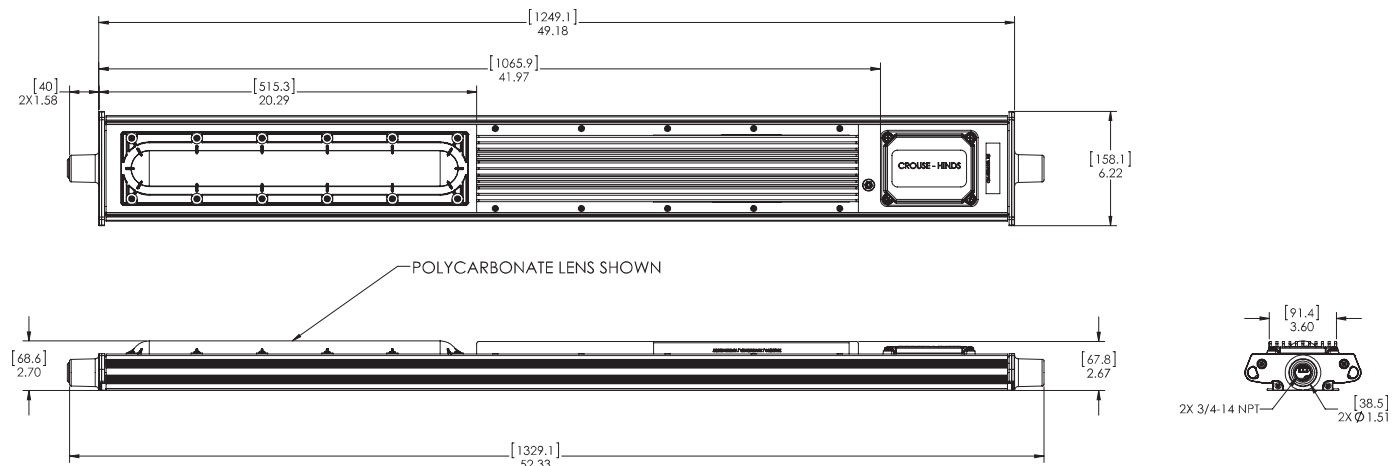

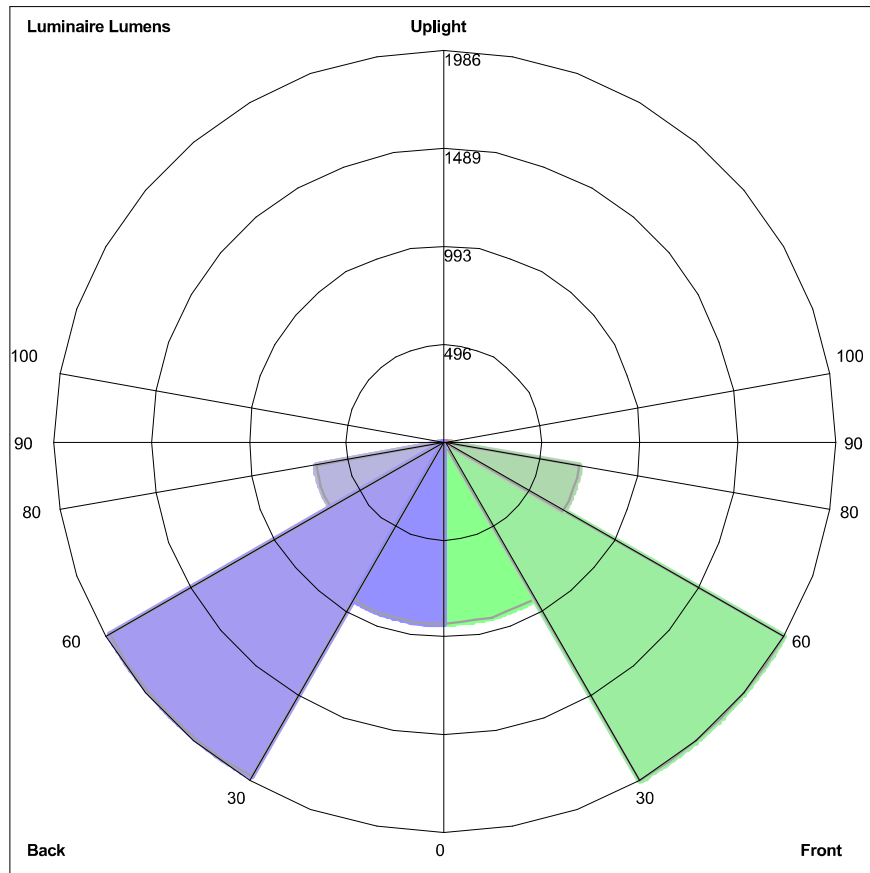

Luminaire Lumens:
 Front: Low=921.0, Medium=1985.6, High=698.7, Very High=29.2
 Back: Low=925.1, Medium=1963.4, High=664.7, Very High=26.5
 Uplight: Low=4.7, High=1.2

BUG Rating : B2-U1-G1

Fixture Cut Sheet

Type E

Pauluhn DLL LED luminaires

For land-based drilling

Cl. I, Div. 2, Groups A, B, C, D
Cl. I, Zone 2
Cl. II, Div. 2, Groups F, G
Cl. III

UL Listed
CSA Certified
Marine & Wet Locations
NEMA 4X; IP66

2L

2L

The Pauluhn™ DLL linear LED is specifically designed to replace fluorescent T12, T8 and T5HO lighting on land-based and offshore drilling platforms. The rugged and durable design features the industry's most versatile and flexible mounting options. The Pauluhn DLL is the ideal solution for high vibration, impact and hose down in drilling applications.

Model	Typical lumens	Watts	Lumens per watt	Equivalent HID luminaire	Typical energy savings / lifetime
DLL2	3,958	32	124	T12HO	Up to 63%
				T8HO	Up to 59%
				T5HO	Up to 47%
				T12	Up to 36%
				T8	Up to 25%
DLL4	7,900	63	130	T5	Up to 9%
				T12HO	Up to 58%
				T8HO	Up to 54%
				T5HO	Up to 43%
				T12	Up to 37%
				T8	Up to 22%
				T5	Up to 10%

Applications:

- Land-based and offshore rigs; areas include: derrick, mast, SCR house, top drive, operator's house, power and pump stations

Features:

- High efficacy: up to 120 LPW
- 40°C to +65°C ambient operating temperature (standard model)
- Low profile (<3" height)
- Versatile ceiling/swivel, wall, flush, pole and pendant mounting options
- Wide and narrow optics for uniform illumination in control room and drill mast
- Four points of secondary retention
- 2,000 PSI high pressure hose rated
- High vibration resistance
- Emergency battery back-up (90 minutes) and surge protection options (up to 10 kV)^A
- DesignLights Consortium® Qualified (some models are not DLC qualified)^B
- 5 year fixture warranty

Standard materials:

- Housing – copper-free aluminum; Corro-free epoxy powder coat (optional)
- Lens – clear polycarbonate; diffused polycarbonate

Photometrics:

- Complete photometrics can be found at www.crouse-hinds.com/photometrics

Temperature performance data:

Ambient temp. °C	Min. temp. supply wire °C	Simultaneous rating		
		Class I, Div. 2	Class II, Div. 2	Class I, Div. 2; Class II, Div. 2
40	60	T6	T6	T6
55	75	T5	T5	T5
65	90	T5	T5	T5



Mounting (ordered separately):

Versatile mounting options:

- Flush back mount
- Swivel/ceiling back mount
- Offset ceiling mount
- Offset wall mount
- Pole mount
- Pendant mount

Easily retrofit to:

- Existing Pauluhn DuraPro and MagnaPro fluorescent light fixtures
- Rig-A-Lite and Snelson C1D2 fluorescent lighting fixtures

Certifications and compliances:

NEC:

- Class I, Division 2, Groups A, B, C, D
- Class I, Zone 2
- Class II, Division 2, Groups F, G
- Class III
- NEMA 4X, IP66
- Marine and wet locations

UL standards:

- UL844 – Electrical Fixture Hangers for Hazardous Locations
- UL1598 – Luminaire
- UL1598A – Luminaire for Installation on Marine Vessels
- UL924 – Emergency Lighting

CSA standard:

- C22.2 No. 137

Additional certifications:

- ABS design assessed

Electrical ratings:

	DLL2	DLL4
Lumen output	3,958	7,900
Frequency	50/60 Hz	50/60 Hz
Voltage	100-277 VAC, 108-250 VDC; 347-480 VAC	

Model	Voltage	Current (A)	Watts	Power factor	THD
DLL2/UNV1	100	0.33	32.5	0.92	<20%
DLL2/UNV1	277	0.13	34.3	0.92	<20%
DLL2/UNV34	347	0.10	32.2	0.92	<20%
DLL2/UNV34	480	0.07	34.5	0.92	<20%
DLL4/UNV1	100	0.63	63.4	0.92	<20%
DLL4/UNV1	277	0.23	62.5	0.92	<20%
DLL4/UNV34	347	0.18	61.4	0.92	<20%
DLL4/UNV34	480	0.13	63.9	0.92	<20%

Weights:

Model	Lbs.	Kg.
DLL2	12.50	5.70
DLL4	22.50	10.20

^AOne year warranty.

^BRefer to www.designlights.org Qualified Products List under Family Models for full listing details. Not all models are approved for all application categories.

Pauluhn DLL LED luminaires

For land-based drilling

Cl. I, Div. 2, Groups A, B, C, D
Cl. I, Zone 2
Cl. II, Div. 2, Groups F, G
Cl. III

UL Listed
CSA Certified
Marine & Wet Locations
NEMA 4X; IP66

2L

2L

Designed for drilling. Pauluhn DLL linear LED luminaires are engineered to handle demanding conditions faced on land-based drilling rigs. The DLL stands up to high vibration, hose down, shock and impact, while delivering long life and high lumen performance for up to 20 years.

Custom optics:

- Standard wide (120°) beam spread for control room and indoor application maximizes illumination on wall panels
- Narrow (80°) beam spread option for high mast/derrick application avoids spillage and light loss

Comprehensive certification:

- Single model certified for use in Class I, Division 2 and Class II, Division 2 harsh and hazardous applications

Quick & easy installation:

- Easy access to drivers and wiring
- No custom brackets or hardware needed
- Seven mounting options available
- Easily retrofit to Pauluhn DuraPro and MagnaPro, Rig-A-Lite and Snelson



Slim profile:

- 2.7" fixture height (excluding mounting brackets)
- Perfect for mounting in confined or low height areas

Built to last:

- Ingress protection from hose down water or diesel fuel in harsh operational conditions – passed 2,000 PSI high pressure test
- Vibration-, impact- and shock-resistant – passed 5G, 3-axis vibration test
- 60,000 hour lifetime at 55°C ambient



Pauluhn DLL LED luminaires

For land-based drilling

Cl. I, Div. 2, Groups A, B, C, D
Cl. I, Zone 2
Cl. II, Div. 2, Groups F, G
Cl. III

UL Listed
CSA Certified
Marine & Wet Locations
NEMA 4X; IP66

2L

2L

Ordering information:

Part number example

DLL4N/UNV1 S903 TF P EM1

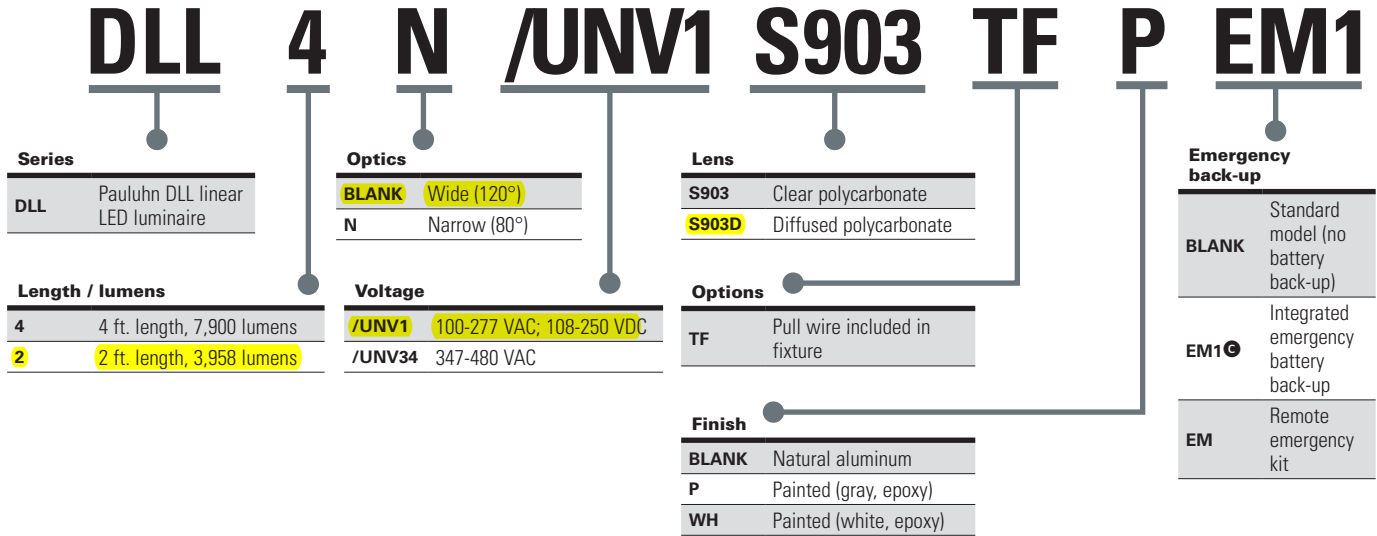

Accessories (ordered separately):

Description	Cat. #	Description	Cat. #
• Flush/back mount back plate.....	DP1057MTK <i>Compatible with DuraPro</i>	• Pendant mount kit.....	PEND HAZ KIT
• Ceiling/swivel mount.....	DP1050MTK <i>Compatible with DuraPro</i>	• Safety chain kit.....	SS KIT
• Ceiling/wall mount offset.....	DP1053MTK <i>Compatible with DuraPro</i>	• 1 amp driver replacement kit, 100-277 VAC for 4 ft. linear.....	VMVL/UNV1 80W 1A KIT
• Ceiling mount bracket and adapter kit.....	MP1054MTK KIT <i>Compatible with MagnaPro</i>	• 1 amp driver replacement kit, 347-480 VAC for 4 ft. linear.....	VMVL/UNV34 80W 1A KIT
• Offset wall mount.....	DP1052MTK <i>Compatible with DuraPro</i>	• 0.5 amp driver replacement kit, 100-277 VAC for 2 ft. linear.....	VMVL/UNV1 80W 0.5A KIT
• Pole mount kit, 1.25" conduit.....	PM KIT 1.25	• 0.5 amp driver replacement kit, 347-480 VAC for 2 ft. linear.....	VMVL/UNV34 80W 0.5A KIT
• Pole mount kit, 1.50" conduit.....	PM KIT 1.5		
• Pole mount kit, 2.00" conduit.....	PM KIT 2.0		

Dimensions and mounting options:

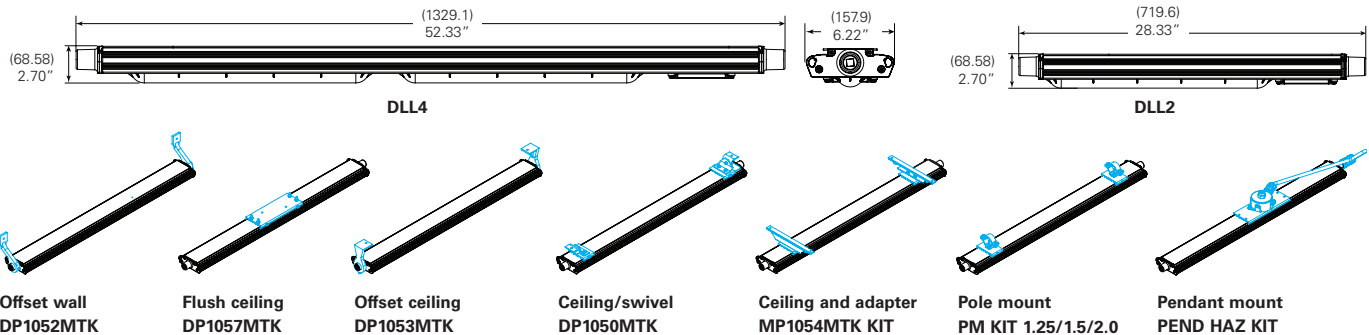

One year warranty. Remote EM kit also available, 120-277 VAC only. Available with 4 ft. model only.

Pauluhn DLL LED luminaires

For land-based drilling

Cl. I, Div. 2, Groups A, B, C, D
Cl. I, Zone 2
Cl. II, Div. 2, Groups F, G
Cl. III

UL Listed
CSA Certified
Marine & Wet Locations
NEMA 4X; IP66

2L

Mounting options:

Ceiling/swivel mount DP1050MTK

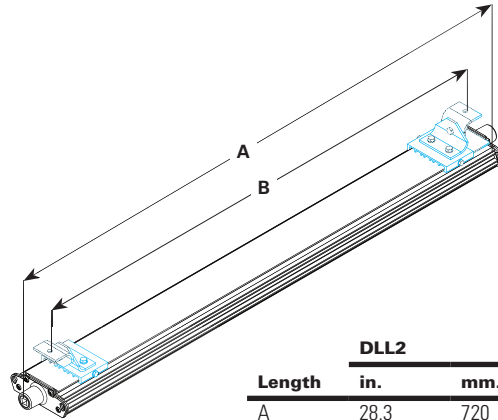
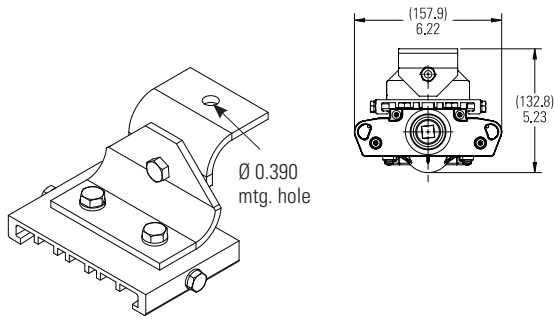

Length	DLL2		DLL4	
	in.	mm.	in.	mm.
A	28.3	720	52.3	1329
B	9-27	222-681	9-51	222-1289

Pole mount PM KIT 1.25/1.5/2.0

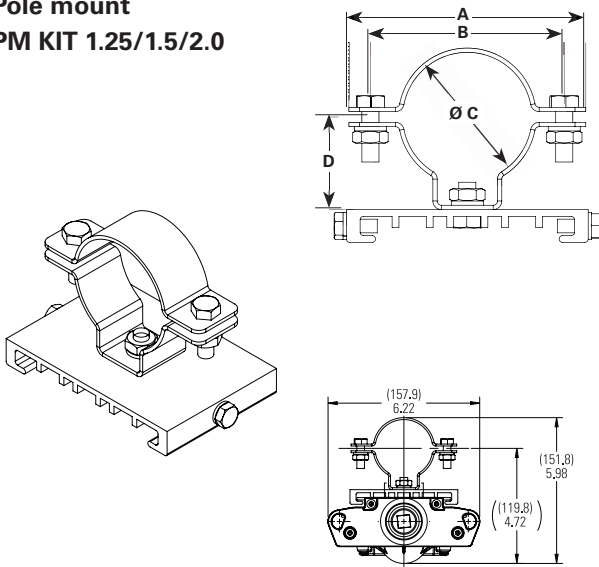

Configuration	ALL MEASUREMENTS IN INCHES			
	A	B	C	D
PM KIT 1.25	4.331	3.543	1.680	1.693
PM KIT 1.5	3.740	2.953	2.000	1.535
PM KIT 2.0	3.386	2.598	2.360	1.378

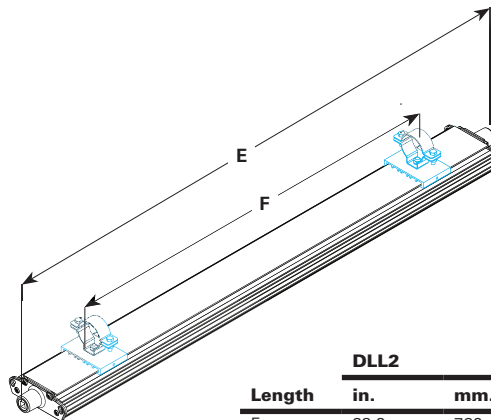

Length	DLL2		DLL4	
	in.	mm.	in.	mm.
E	28.3	720	52.3	1329
F	12-21	305-533	24-45	610-1143

MagnaPro mount MP1054MTK KIT

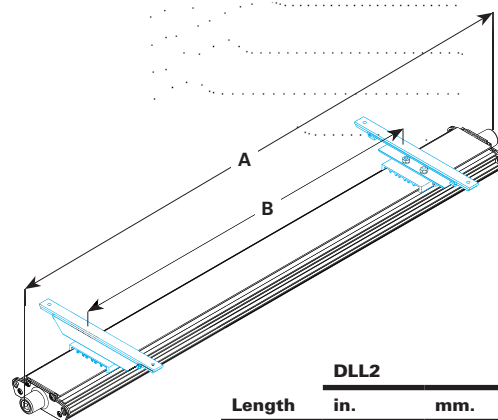
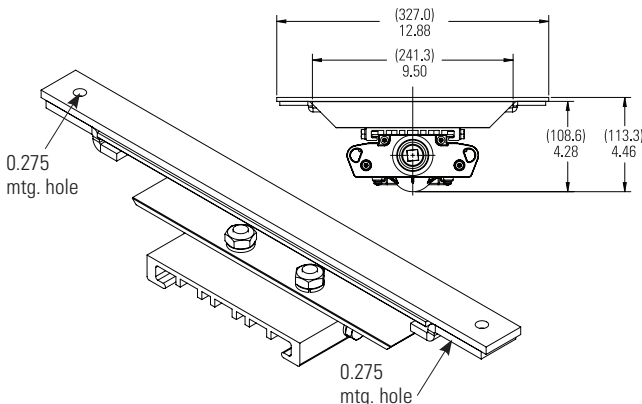

Length	DLL2		DLL4	
	in.	mm.	in.	mm.
A	28.3	720	52.3	1329
B	12-22	305-559	24-46	610-1168

Pauluhn DLL LED Luminaires

For land-based drilling

Cl. I, Div. 2, Groups A, B, C, D
Cl. I, Zone 2
Cl. II, Div. 2, Groups F, G
Cl. III

UL Listed
CSA Certified
Marine & Wet Locations
NEMA 4X; IP66

2L

2L

Mounting options (continued):

Offset wall DP1052MTK

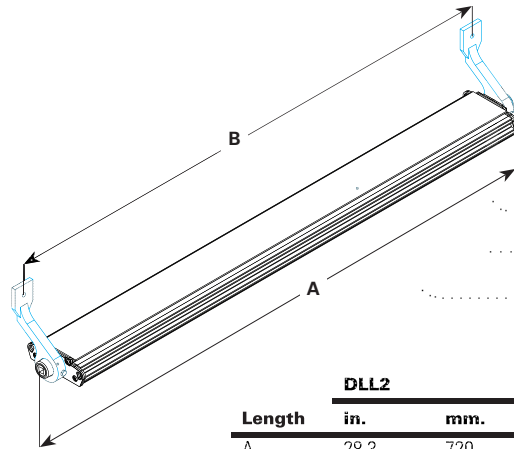
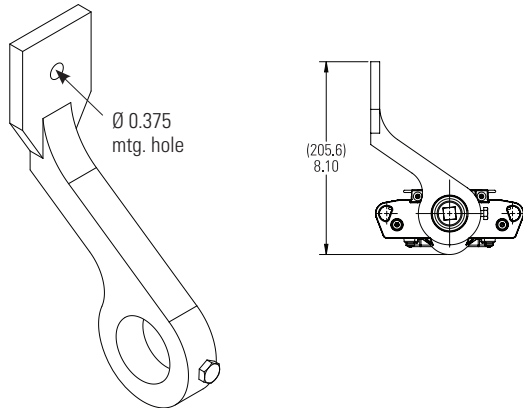

Length	DLL2		DLL4	
	in.	mm.	in.	mm.
A	28.3	720	52.3	1329
B	26.3	669	50.3	1278

Offset ceiling/wall mount DP1053MTK

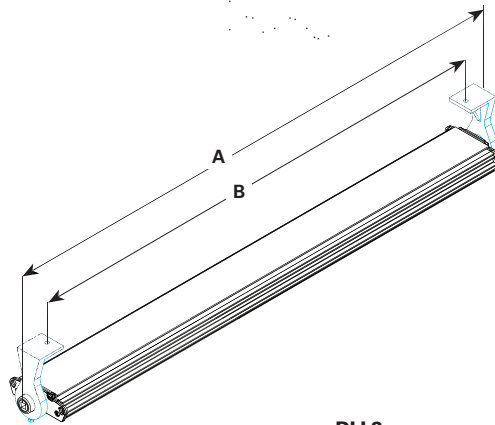
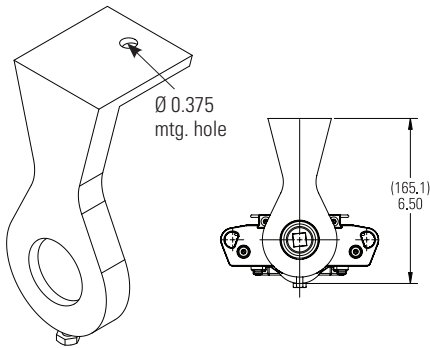

Length	DLL2		DLL4	
	in.	mm.	in.	mm.
A	28.3	720	52.3	1329
B	26.3	584	47.0	1194

Flush ceiling DP1057MTK

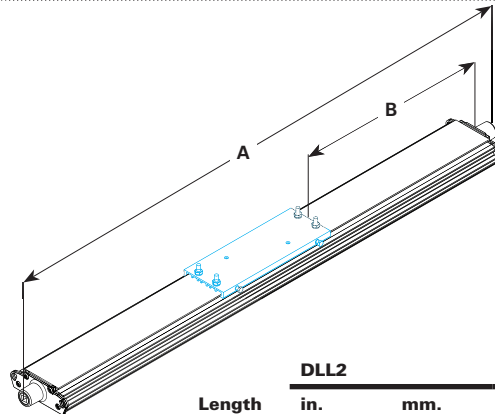
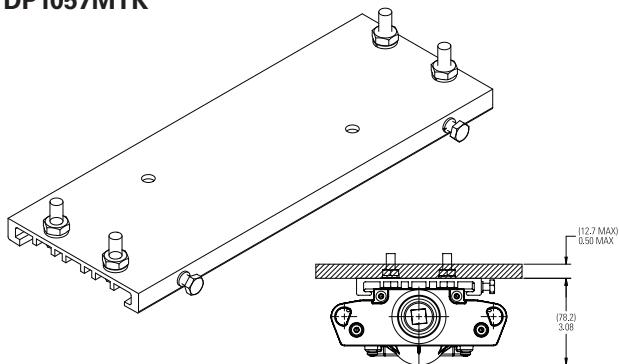

Length	DLL2		DLL4	
	in.	mm.	in.	mm.
A	28.3	720.0	52.3	1329.0
B	6.2	157.5	18.2	462.0

Pauluhn DLL LED luminaires

For land-based drilling

Cl. I, Div. 2, Groups A, B, C, D
Cl. I, Zone 2
Cl. II, Div. 2, Groups F, G
Cl. III

UL Listed
CSA Certified
Marine & Wet Locations
NEMA 4X; IP66

2L

2L

Mounting options (continued):

Pendant mount – Class I, Division 2 only
PEND HAZ KIT

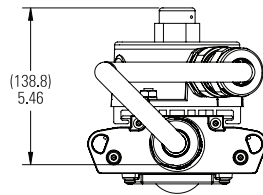
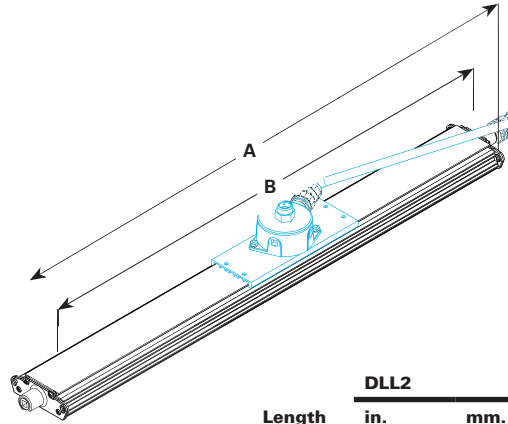
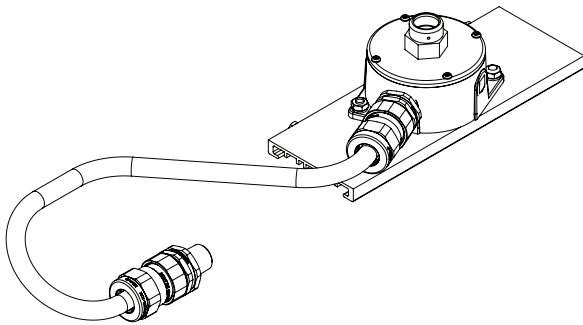

Length	DLL2		DLL4	
	in.	mm.	in.	mm.
A	31.7	805	55.8	1418
B	28.3	720	52.3	1329
C	4.2	108	16.0	406
D	12.2	310	24.0	610
E	34.9	886	58.9	1495

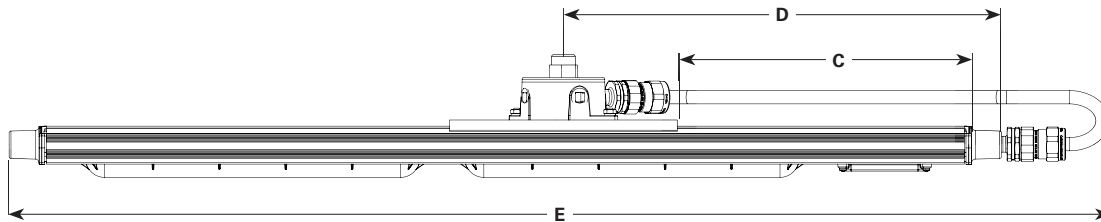

Pauluhn DLL LED luminaires

Integral battery back-up

Cl. I, Div. 2, Groups A, B, C, D
Cl. II, Div. 2, Groups F, G

UL Listed
CSA Certified
Wet Locations
Type 4X; IP66

2L

2L

Pauluhn DLL linear LED luminaires are available with an integral battery back-up module. Virtually the same size as the standard 4 foot model and 90 minutes of emergency lighting to keep your facility and personnel safe.

Model	EM output	Normal output
DLL4/UNV1 S903 EM1	1,400 lumens (100-277V)	6,720 lumens (100-277V)

Applications:

- Egress and emergency lighting for areas requiring uninterrupted lighting during power failure
- Hazardous rated indoor and outdoor emergency lighting in manufacturing plants, heavy industrial, chemical and petrochemical facilities, platforms, loading docks and parking areas

Features:

- Operating ambient: 0°C to +40°C
- 90-minute run time in emergency mode
- 6,720 lumen output for normal operation; 1,400 lumen output in emergency mode
- 50,000 hours rated life at 40°C
- IP66 rated enclosure
- LED indicator to check battery operation
- Nickel cadmium battery
- 1 year warranty

Certifications and compliances:

NEC/CEC:

- Class I, Division 2, Groups A, B, C, D
- Class II, Division 2, Groups F, G
- Wet locations, Type 4X, IP66

UL standards:

- UL844 – Hazardous (Classified)
- UL1598 – Luminaires
- UL1598A – Marine
- UL924 – Emergency Lighting

CSA standard:

- CSA C22.2 Nos. 137, 141

Dimensions:

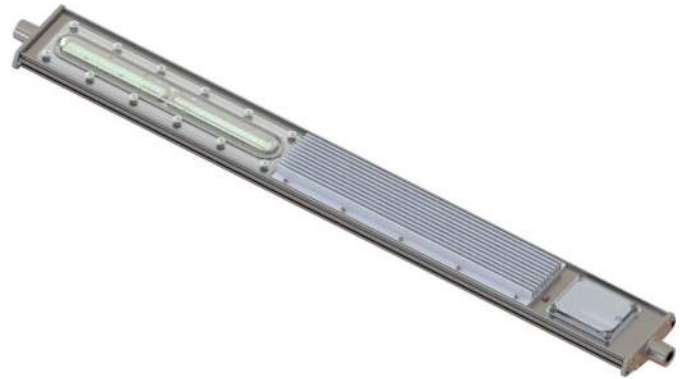
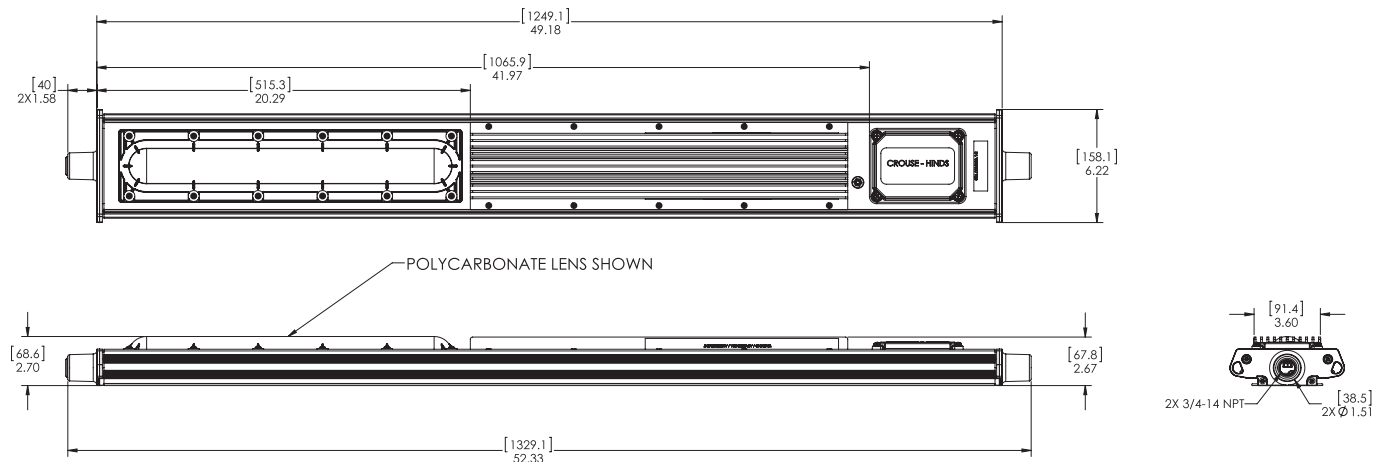

Electrical ratings:

	EM output	Normal output
Voltage	120	277
Amperage at 120 VAC	0.480	0.212
Wattage at 120 VAC	57.8	57.7
Lumen output	1,400	6,720
Frequency	50/60 Hz	50/60 Hz
Power factor at 100 VAC	>0.90	>0.90
THD	6.58	11.70

Temperature performance data:

Ambient temp. °C	Min. temp. supply wire °C	Simultaneous rating		
		Class I, Div. 2	Class II, Div. 2	Class I, Div. 2; Class II, Div. 2
40	60	T5	T6	T5

Photometrics:

- Complete photometrics can be found at www.crouse-hinds.com/photometrics

LUMINAIRE CLASSIFICATION SYSTEM (LCS) GRAPH

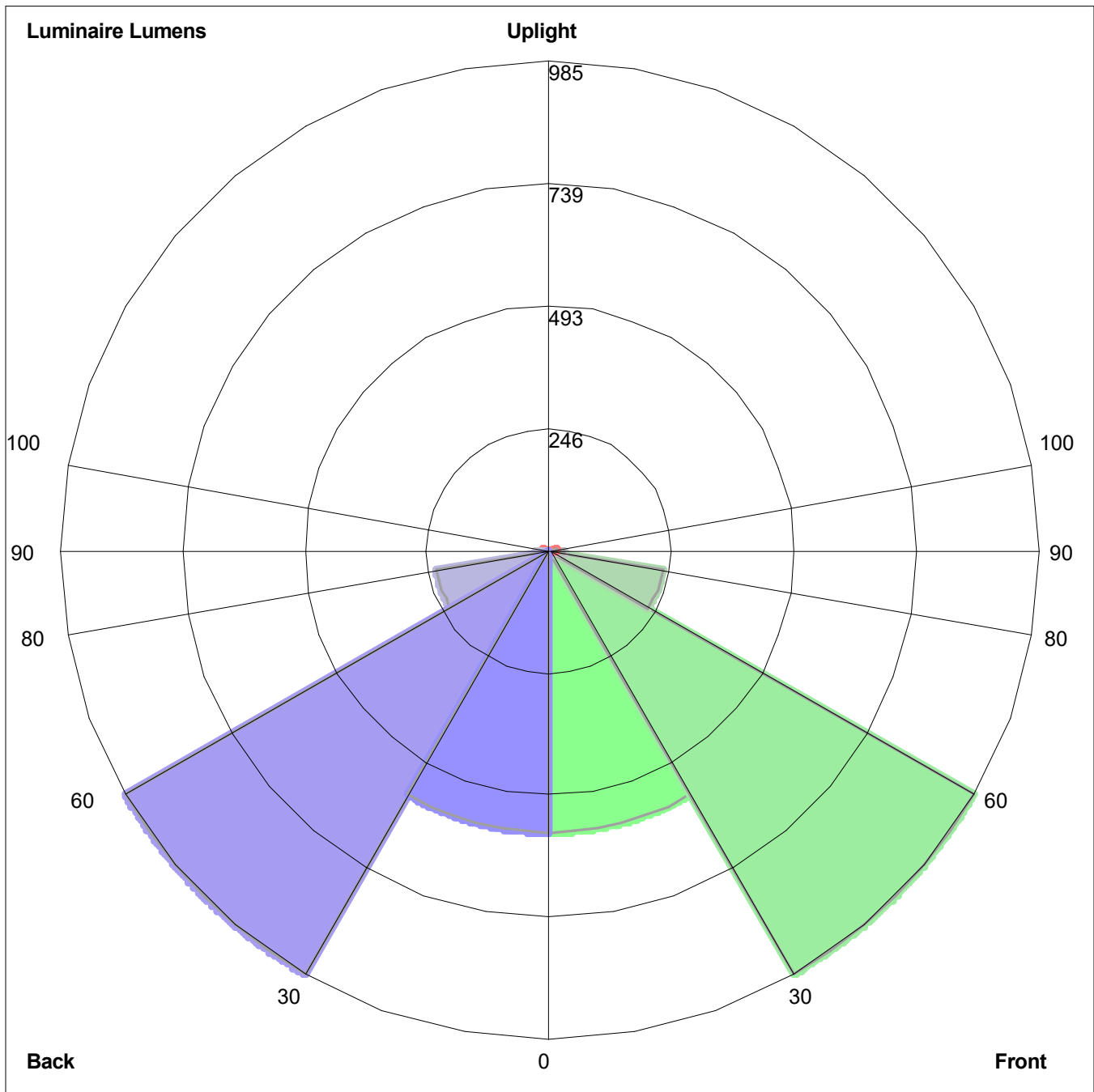

Luminaire Lumens:
Front: Low=568.6, Medium=985.4, High=230.6, Very High=28.4
Back: Low=568.6, Medium=985.4, High=230.6, Very High=28.4
Uplight: Low=12.8, High=0.3

BUG Rating : B2-U2-G1

Fixture Cut Sheet

Type F



Mounting: Vertical Green LED Heat Trace End Seal Kit

Mounting Height: Piping Height Varies.

Part Number: E-100-L-A

Manufacturer: Raychem

Wattage: 2 watts at 60 Lumens/watt LED. 120 Lumens per end seal

APPROVALS

E-100-E	E-100-L-E
PTB 09 ATEX 1060 U Ⓜ II 2G Ex e II II 2D Ex tD A21 IP66 IECEx PTB 09.0038U Ex e II Ex tD A21 IP66 Ⓜ Ex e II T*	Sira 14ATEX3015X Ⓜ II 2GD Ex e mb IIC T* Gb Ex tb IIIC T***°C Db Ta = -40°C to +40°C IECEx SIR 14.0007X Ex e mb IIC T* Gb Ex tb IIIC T***°C Db Ta = -40°C to +40°C FM CLI, ZN1, AEx e mb IIC T* Gb (1) ZN21 AEx tb IIIC T* Ⓜ Ex e mb IIC T* Gb Ⓜ Ex tb IIIC T***°C Db
DNV Certificate No. E-11564 and E-11565 *For T-rating, see heating cable or design documentation (1) Except VPL	
EAC Ex TC RU C-BE.MI062.B.00054/18 Ex e IIC Gb U Ex tb IIIC Db U Ex e mb IIC Gb U Ex tb mb IIIC Db U Ta -55°C...+56°C IP66 000 "ТехИмпорт"	EAC Ex TC RU C-BE.MI062.B.00054/18 Ex e IIC Gb U Ex tb IIIC Db U Ex e mb IIC Gb U Ex tb mb IIIC Db U Ta -55°C...+56°C IP66 000 "ТехИмпорт"

PRODUCT SPECIFICATIONS

	E-100-E	E-100-L-E
Max. pipe temperature	Refer to heating cable specification (absolute maximum is 260°C)	
Max. operating voltage	480 V*	277 V
	*Extra conditions for safe use apply for voltages above 277 V. Please refer to the certificate or installation instructions for full details.	
Ambient temperature range	-50°C to +56°C*	-40°C to +40°C
	*Extra conditions for safe use apply for ambient temperatures above +40°C. Please refer to the summary the certificate or installation instructions for full details.	
Min. installation temperature	-50°C	-40°C
Overall height	171 mm	197 mm
Outer diameter	46 mm Usable with up to 100 mm thermal insulation	66 mm
Ingress protection	IP66, Type 4X	IP66, Type 4X
Impact resistance	EN 60079-30-1, ≥ 7 joules	EN 60079-30-1, ≥ 7 joules
UV stability	No degradation after > 1000 h	No degradation after > 1000 h
Solvent resistance	Excellent	Excellent
Strain relief	> 250 N	> 250 N

LIGHT SOURCE

Type	Green LEDs
Voltage rating range	110-277 Vac, 50/60 Hz
Power consumption	< 2 W
Electromagnetic immunity/emissions	Complies with IEC61000-6 and IEC61000-4

INSTALLATION DATA

Tools required	Cable knife, wire cutters, screwdriver	Cable knife, wire cutters, screwdriver, crimp tool (Panduit-CT-100), long nose pliers
----------------	--	---

ORDERING DETAILS

End seal

Part description	E-100-E	E-100-L-E
PN (Weight)	101255-000 (0.22 kg) Requires one pipe strap (not supplied)	P000001583 (0.63 kg) Requires one pipe strap (not supplied) PTB, DNV and EAC approved product

ACCESSORIES

Small pipe adaptor JBS- SPA, required for pipes $\leq 1"$ (DN 25), E 90515-000 (bag of 5 adaptors)

SPARE PART

Boot pack for E-100-E

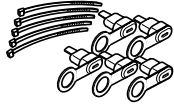

Part description	E-100-BOOT-5-PACK
PN (Weight)	281053-000 (140 g)
Pack size	5 sealant filled boots and 5 cable ties

Replacement indicator light for E-100-L

Part description:	E-100-LR-E
PN	P000001586

North America

Tel +1.800.545.6258
Fax +1.800.527.5703
thermal.info@nVent.com

Europe, Middle East, Africa

Tel +32.16.213.502
Fax +32.16.213.604
thermal.info@nVent.com

Asia Pacific

Tel +86.21.2412.1688
Fax +86.21.5426.3167
cn.thermal.info@nVent.com

Latin America

Tel +1.713.868.4800
Fax +1.713.868.2333
thermal.info@nVent.com



Our powerful portfolio of brands:

nVent.com

CADDY

ERICO

HOFFMAN

RAYCHEM

SCHROFF

TRACER

LUMINAIRE CLASSIFICATION SYSTEM (LCS) GRAPH

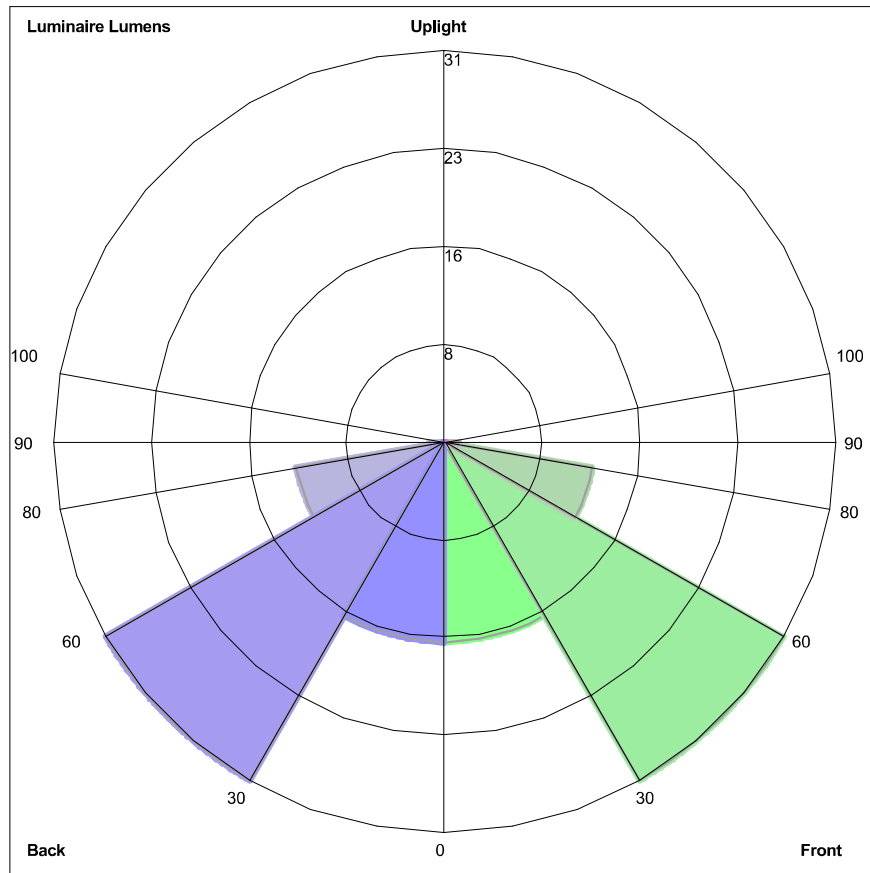

Luminaire Lumens:
Front: Low=16.0, Medium=31.2, High=12.0, Very High=1.2
Back: Low=16.0, Medium=31.2, High=12.0, Very High=1.2
Uplight: Low=0.0, High=0.0

BUG Rating : B0-U0-G0

Fixture Cut Sheet

Type G

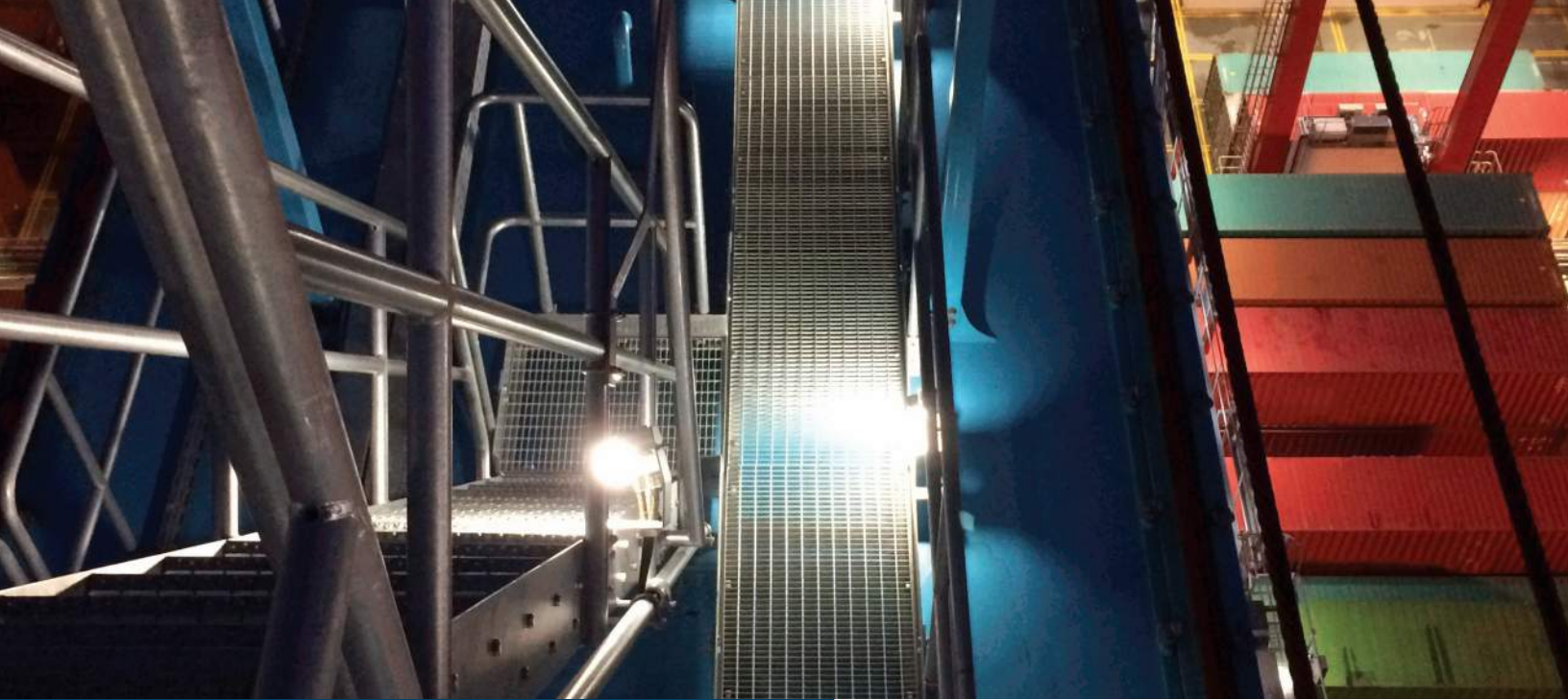

PHOENIX[®]
DURABILITY X DESIGN™



Cube-Light

Compact LED Area Light

Australian Design No. 359170
US Patent No. D762,321 S

Delivers up to 1000 lumens to doorways, walkways, cabins or other small areas

Competitive pricing with short lead times

Various mounting options for maximum versatility

LED technology increases efficiency, eliminates maintenance and supports green initiatives

Dimensions

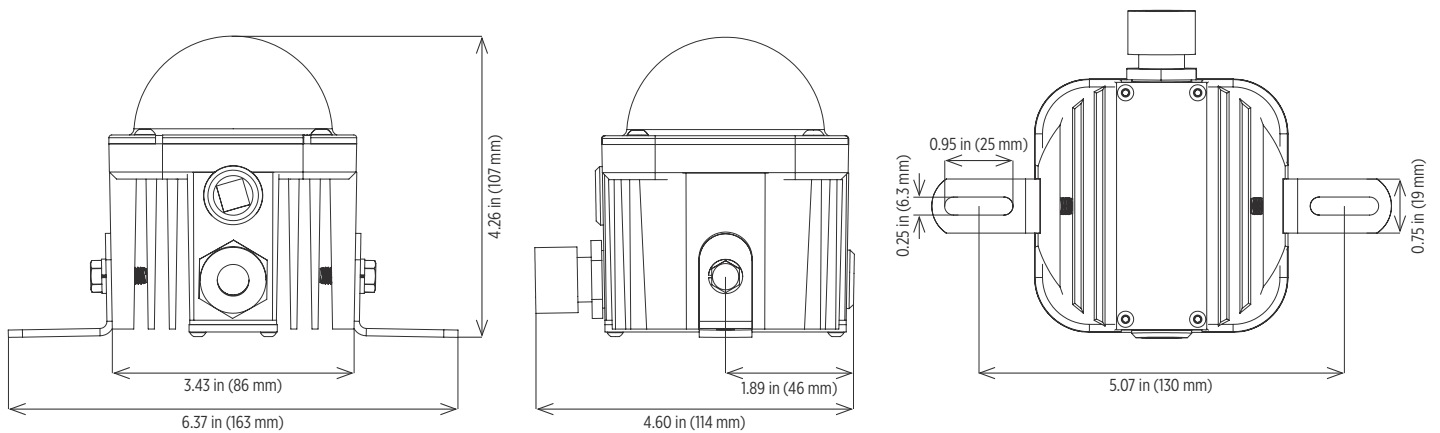

Cube-Light

Compact LED Area Light

Specifications

Construction	Cast aluminum housing
Finish	White thermoset powder coat
Hardware	Marine grade (316) stainless steel
Lens	Impact-resistant, diffuse polycarbonate Diffuse red, green, blue and amber lens accessories available (AMB-CL, BLU-CL, GRN-CL, RED-CL)
Light source	13W, up to 1000 lumens Conformal coated CRI ≥ 70 CCT 5000K 50,000 hour rated life
Power source	120-240V, 50/60Hz 240V, 50/60Hz 13-27V DC
Wiring	Stranded wires Cord not included - standard 72.00 inch (1829 mm) cord with pigtail option (CD) NEMA 5-15 plug (120V only) sold separately (PLG-515)
Through wiring	Continuous row mounting option (TW)
Ambient operating temperature	-30°C to +50°C
Mounting	Flush mount brackets - standard Harp mount available Rail mount available - 2.00 inch overall diameter Fixture can be mounted in any orientation
Weight	2.0 lb (0.9 kg)
Warranty	3 years

For IES files, see website or contact factory

Compliances

ETL/cETL Listed to:

- UL 1598 Suitable for Wet Locations
- UL 1598A Marine Outside Type (Saltwater)
- CSA C22.2 No. 250.0

CE

ABS

IP66 rated

LM79 and LM80 reports available



The Cube-Light on an STS crane



Ordering Information

Example: CL-13LED-120-240

Fixture	Wattage/Type	Voltage	Options
CL	13LED	120-240 ^{1,2} 240 ² DC ³	CD TW

Wattage/Type	Voltage	Options	Notes
13LED 13W, up to 1000 lumens	120-240 ^{1,2} 120-240V, 50/60Hz 240 ² 240V, 50/60Hz DC ³ 13-27V DC	CD 72.00 inch (1829 mm) cord with pigtail option TW Continuous row mounting	1 ETL/cETL listed 2 CE 3 No certifications

Special Projects: We may be able to accommodate your special projects, so please don't hesitate to ask about additional options. Minimum order quantities and/or extended lead times will apply. Contact your Phoenix representative with specific inquiries.

Mounting (order separately)

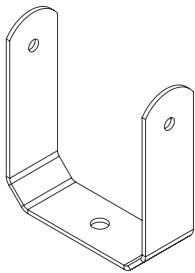

Harp Mount
HRP-CL

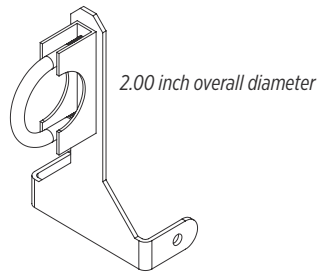

Rail Mount
RLMT-CL
Contact factory

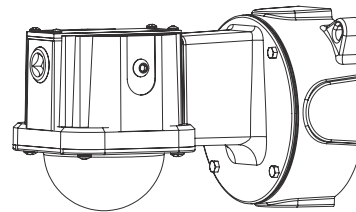

Wall Mount
Complete fixture sold separately
Refer to Cube-Light Wall Mount spec sheet

Flush mount comes standard with fixture

Accessories (order separately)

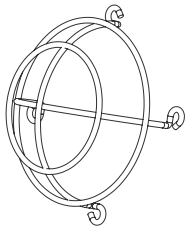

Wire Guard Kit
WG-CL

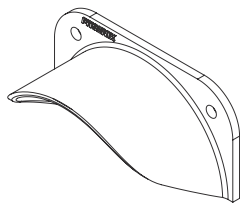

Visor Kit
VSR-CL

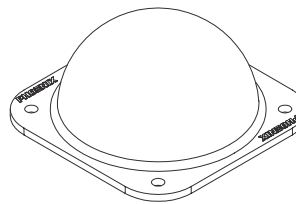

Color Lens Kits
AMB-CL amber lens kit
BLU-CL blue lens kit
GRN-CL green lens kit
RED-CL red lens kit

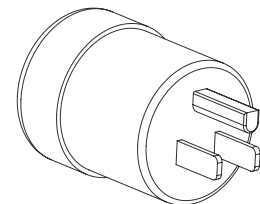

NEMA 5-15 plug (120V only)
PLG-515



LUMINAIRE CLASSIFICATION SYSTEM (LCS) GRAPH

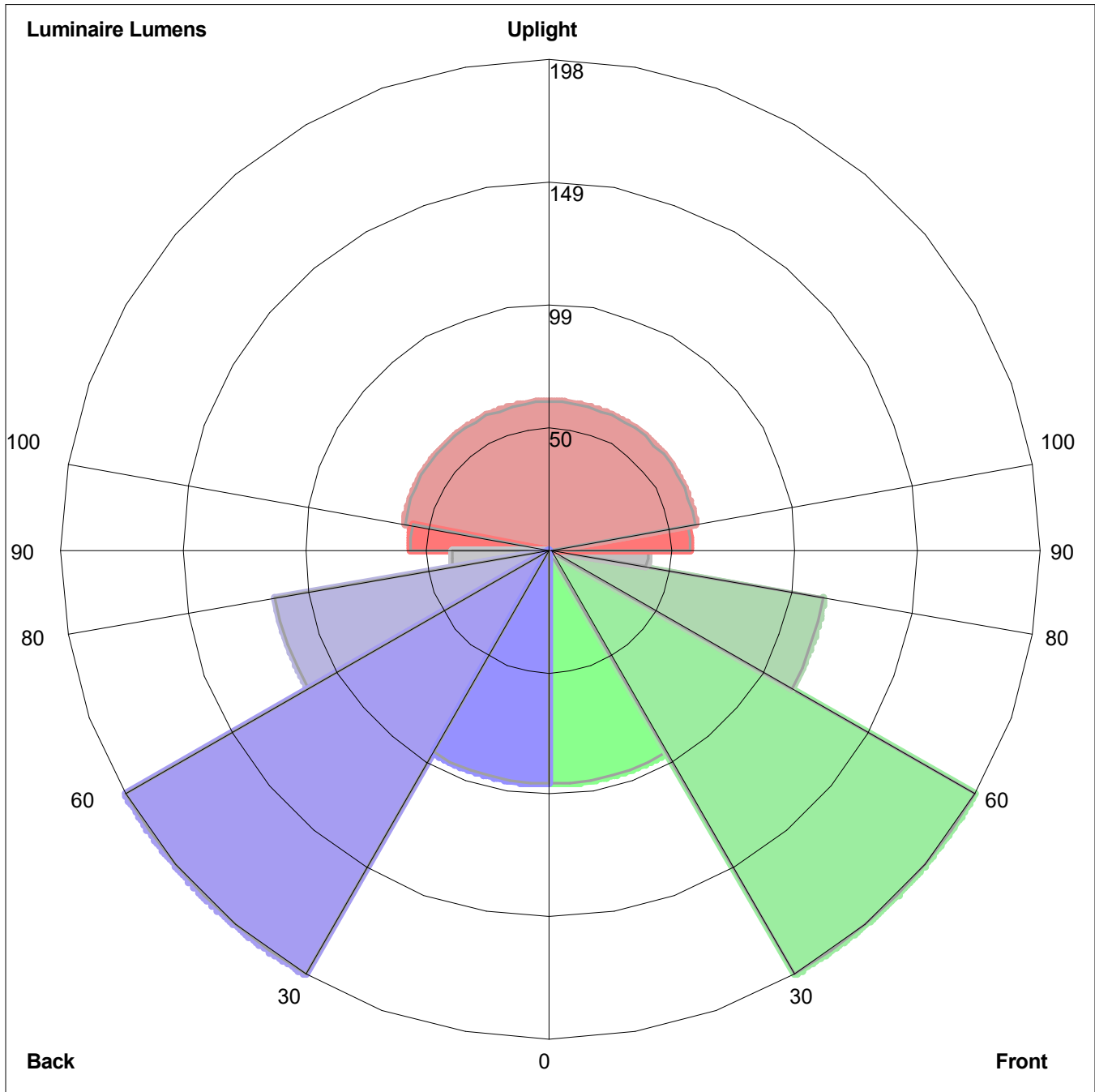

Luminaire Lumens:
Front: Low=94.7, Medium=198.1, High=112.5, Very High=39.7
Back: Low=94.7, Medium=198.1, High=112.5, Very High=39.7
Uplight: Low=56.4, High=59.7

BUG Rating : B1-U3-G1