



TOPSOIL PROTECTION PLAN
FOR
Washington Pad

Prepared For:



1120 Lincoln Street, Suite 801
Denver, Colorado, 80203

Prepared By:



1720 Bellaire Street, Suite 202
Denver, CO 80202
www.rpgres.com

Date Prepared: September 2022

Table of Contents

| | |
|--|---|
| 1. INTRODUCTION..... | 3 |
| 2. SITE DESCRIPTION | 3 |
| 2.1. General..... | 3 |
| 2.2. Topography and Land use..... | 3 |
| 2.3. Natural features..... | 3 |
| 3. FIELD OBSERVATIONS | 3 |
| 3.1. Methodology..... | 3 |
| 3.2. Soil Physical & Morphological Characteristics | 4 |
| Table 1. Soil Test Pit Characteristics | 5 |
| 3.3. Laboratory Results | 6 |
| 3.4. Conclusions | 6 |
| 4. OPERATIONAL PHASES..... | 6 |
| 4.1. Construction Activities | 6 |
| 4.1.1. Soil removal and segregation..... | 6 |
| 4.1.2. Rocky or Thin Soil Horizons..... | 6 |
| 4.2. Drilling and Completions..... | 7 |
| 4.2.1. Protection of Soils | 7 |
| 4.2.2. Weed Management | 7 |
| 4.2.3. Maintenance & Repairs..... | 7 |
| 4.3. Interim Reclamation | 7 |
| 4.3.1. Stockpile Management. | 7 |
| 4.3.2. Inspections | 7 |
| 5. SITE-SPECIFIC BMPS | 8 |

APPENDIX A – Soil Sample Photos

APPENDIX B – Topsoil Protection Plan Exhibit

APPENDIX C – BMP Datasheets

APPENDIX D – Seed Mix

1. INTRODUCTION

This Topsoil Protection Plan (Plan) was prepared by RPG Resources, LLC (RPG) to support Extraction Oil & Gas, Inc. (Civitas Resources, Inc; hereafter Extraction) in preparing Form 2A to permit the new Washington Pad location.

The intent of this plan is to provide site-specific guidance and recommended best management practices (BMPs) for topsoil management throughout the construction and interim reclamation project phases. The operator has developed this plan to comply with federal, state, and local criteria and guidelines, as they relate to topsoil management. The following procedures will be implemented to ensure protection of soils through all oil and gas exploration and production phases.

2. SITE DESCRIPTION

2.1. General

The Washington Pad will be located entirely within privately owned property within Township 1S 68W, Section 10 in Adams County, Colorado, at approximately 5165 – 5200 feet in elevation. For the purposes of this plan, the limit of disturbance refers to the proposed Oil and Gas Location and is hereafter referred to as the Site. The Washington Pad is scheduled to be constructed upon permit approval.

2.2. Topography and Land use

The Site generally slopes to the east at a 2-10% grade. The Site is located on agricultural land within a highly disturbed area adjacent to vehicular traffic and planned industrial development. Currently active oil and gas facilities operated by Extraction are located approximately 700 feet to the southeast.

2.3. Natural features

Bull Canal, a concrete lined irrigation ditch, intersects the proposed development area approximately 0.25 miles west of Washington Street. The portion of Bull Canal which intersects the Site is isolated, inactive and has been deeded back to the landowner. Given the feature's isolated status, it is not considered a constraint for this project. All other wetland and current water features in the vicinity are located outside the Site. Impacts to wetlands and waterways are not anticipated as a part of this project.

3. FIELD OBSERVATIONS

3.1. Methodology

Topsoil depth was evaluated using physical and morphological soil characteristics. As described below, eight (8) soil test pits, each measuring approximately 36 inches in depth, were evaluated across the proposed disturbance area for the Washington Pad (See Appendix A). Soil colors were evaluated using a Munsell Soil Color Book. Eight (8) of eight (8) test pit locations had soil samples collected within the proposed topsoil salvage depths. Soil samples were submitted to Weld Laboratories in Greeley, CO for analysis of baseline agronomic soil properties. The results will be used to apply topsoil reclamation amendments as needed.

As detailed below, four (4) soil types were identified by the United States Department of Agriculture (USDA) Natural Resource Conservation Service (NRCS) Web Soil Survey (WSS): Platner loam 0-3% slopes (PIB), Platner loam 3-5% slopes (PIC), Ulm loam 3-5% slopes (UIC), and Ulm loam 5-9% slopes (UID).

Naming conventions of the test pits discussed within the subsections below refer to the WSS map unit symbology.

Platner loam 0-3% slopes (PIB) covers approximately 5.6 acres of land within the proposed disturbance area, and two test pits were dug within the mapped limits of soil type PIB, described below as PIB-1 and PIB-2. Platner loam 3-5% slopes (PIC) covers approximately 4.9 acres of land within the proposed disturbance area, and two test pits were dug within the mapped limits of soil type PIC, described below as PIC-1, and PIC-2. Ulm loam 3-5% slopes (UIC) covers approximately 3.0 acres within the proposed disturbance area, and two test pits were dug within the mapped limits of soil type UIC, described below as UIC-1, and UIC-2. Ulm loam 5-9% slopes (UID) covers approximately 0.7 acres within the proposed disturbance area, and two test pits were dug within the mapped limits of soil type UID, described below as UID-1, and UID-2.

3.2. Soil Physical & Morphological Characteristics

In test pit PIB -1 the A horizon (topsoil) was measured from 0 to 6 inches below ground surface with a hue of 10YR, value of 5, chroma of 3 and loam texture. The B horizon (subsoil) was measured from 6 to 24 inches below ground surface with a color of 10YR 4/3 with a clay texture. The C horizon (substratum) was observed from 24 to 36 inches with a color of 10YR 5/6, and a clay texture.

In test pit PIB-2 the A horizon (topsoil) was measured from 0 to 9 inches below ground surface with a color of 10YR 4/4, and loam texture. The B horizon (subsoil) was measured from 12 to 27 inches below ground surface with a color of 10YR 4/3, and a clay texture. The C horizon (substratum) was observed from 27 to 36 inches below ground surface with a color of 10YR 4/4, and a clay texture.

In test pit PIC-1 the A horizon (topsoil) was measured from 0 to 9 inches below ground surface with a color of 10YR 5/3, and a loam texture. The B horizon (subsoil) was measured from 9 to 24 inches below ground surface with a color of 10YR 4/3, and a clay loam texture. The C horizon (substratum) was measured from 24 to 36 inches below ground surface with a color of 10YR 5/2, and a clay loam texture.

In test pit PIC-2 the A horizon (topsoil) was measured from 0 to 12 inches below ground surface with a color of 10YR 5/3, with a clay loam texture. The B horizon (subsoil) was measured from 12 to 25 inches below ground surface with a color of 10YR 5/3, and a clay texture. The C horizon (substratum) was measured from 25 to 36 inches below ground surface with a color of 10YR 5/3 and a clay texture. Calcium carbonate deposits were observed within the substratum layer.

In test pit UIC-1 the A horizon (topsoil) was measured from 0 to 6 inches below ground surface with a color of 10YR 5/3 and a clay loam texture. The B horizon (subsoil) was measured from 6 to 27 inches below ground surface with a color of 10YR 4/3, and a clay texture. The C horizon (substratum) was measured from 27 to 36 inches below ground surface with a color of 10YR 5/6, and a clay texture.

In test pit UIC-2 the A horizon (topsoil) was measured from 0-12 inches below ground surface with a color of 10YR 4/4, and a loam texture. The B horizon (subsoil) was measured from 12 to 36 inches below ground surface with a color of 10YR 6/3, and a loam texture. A C horizon (substratum) was not observed within soil test pit UIC-2.

In test pit UID-1 the A horizon (topsoil) was measured from 0-9 inches below ground surface with a color of 10YR 4/4 and a loam texture. The B horizon (subsoil) was measured from 9 to 36 inches below ground

surface with a color of 10YR 6/3, and a loam texture. A C horizon (substratum) was not observed within soil test pit UID-1.

In test pit UID-2 the A horizon (topsoil) was measured from 0 to 9 inches below ground surface with a color of 10YR 4/4 and a loam texture. The B horizon (subsoil) was measured from 9 to 16 inches below ground surface with a color of 10YR 5/4, and a loam texture. The C horizon (substratum) was measured from 16 to 36 inches below ground surface with a color of 10YR 8/1, and a clay loam texture.

Table 1. Soil Test Pit Characteristics

| Test Pit | A Horizon (topsoil) | B Horizon (subsoil) | C Horizon (substratum) |
|----------|---|---|--|
| PIB-1 | Depth: 0-6 inches Color: 10YR 5/3 Texture: clay loam | Depth: 6-24 inches Color: 10YR 4/3 Texture: clay | Depth: 24-36 inches Color: 10YR 5/6 Texture: clay |
| PIB-2 | Depth: 0-12 inches Color: 10YR 4/3 Texture: loam | Depth: 12-27 inches Color: 10YR 4/3 Texture: clay | Depth: 27-36 inches Color: 10YR 4/3 Texture: clay |
| PIC-1 | Depth: 0-9 inches Color: 10YR 5/3 Texture: loam | Depth: 9-24 inches Color: 10YR 4/3 Texture: clay loam | Depth: 24-36 inches Color: 10YR 5/2 Texture: clay loam |
| PIC-2 | Depth: 0-12 inches Color: 10YR 5/3 Texture: clay loam | Depth: 12-25 inches Color: 10YR 5/3 Texture: clay | Depth: 25-36 inches Color: 10YR 5/3 Texture: clay |
| UIC-1 | Depth: 0-6 inches Color: 10YR 5/3 Texture: clay loam | Depth: 6-27 inches Color: 10YR 4/3 Texture: clay | Depth: 27-36 inches Color: 10YR 5/6 Texture: clay |
| UIC-2 | Depth: 0-12 inches Color: 10YR 4/4 Texture: loam | Depth: 12-36 inches Color: 10YR 6/3 Texture: loam | Not observed |
| UID-1 | Depth: 0-9 inches Color: 10YR 4/4 Texture: loam | Depth: 9-36 inches Color: 10YR 6/3 Texture: loam | Not observed |
| UID-2 | Depth: 0-9 inches Color: 10YR 4/4 Texture: loam | Depth: 9-16 Color: 10YR 5/4 Texture: loam | Depth: 16-36 inches Color: 10YR 8/1 Texture: clay loam |

3.3. Laboratory Results

Soil samples were submitted to Weld Laboratories in Greeley, CO for analysis of baseline agronomic properties. The results will be referenced in the case of poor revegetation and used to propose topsoil amendments as necessary.

3.4. Conclusions

The topsoil horizon was measured at an approximate depth of up to twelve (12) inches across the site with the majority of organic material observed was within the first six (6) inches. Observed topsoil color was recorded as 10YR 5/3, 10YR 4/3, and 10YR 4/4. Topsoil texture was recorded consistently as loam or clay loam. Salvaged topsoil will be stored along the eastern edge of the pad at a height of approximately 10 feet and with slopes no greater than 3:1. Stockpiles will be vertically tracked by heavy equipment to wind and water erosion during active construction.

4. OPERATIONAL PHASES

4.1. Construction Activities

4.1.1. Soil removal and segregation

During all excavation activities on site, the Operator shall separate and store soil horizons separately from one another and mark or document stockpile locations to facilitate subsequent Reclamation. When separating soil horizons, the Operator shall segregate horizons based upon noted changes in physical characteristics such as organic content, color, texture, density, or consistency. Since the Site is located on cropland, Segregation will be performed to the extent practicable to a depth of six (6) feet or bedrock, whichever is shallower.

4.1.2. Rocky or Thin Soil Horizons

This Site is not expected to have rocky soil horizons within any of the proposed excavation areas. However, if encountered, the Operator shall use best practices to properly segregate and store the topsoil to the extent practicable.

Too rocky shall mean that the soil horizon consists of greater than thirty-five percent (35%) by volume rock fragments larger than ten (10) inches in diameter. Too thin shall mean soil horizons that are less than six (6) inches in thickness. The Operator shall segregate remaining soils to the extent practicable to a depth of six (6) feet below the ground surface or bedrock, whichever is shallower, based upon noted changes in physical characteristics such as color, texture, density or consistency and such soils shall be stockpiled to avoid loss and mixing with other soils.

It is anticipated that topsoil will be stockpiled on location for a duration greater than 30 days. All stockpiled topsoil shall be stabilized as soon as possible, but no later than 14 days after completion of construction activities. All topsoil stockpiles will be drill seeded and mulched using a certified weed free mixture or similar hydroseeding application with binding agent to ensure seed takes to soil. Surface roughening should occur prior to seeding to assist the holding seed/mulch and or hydroseed, particular after rain events.

Approximately 250,722 cubic feet (9,286 cubic yards) of total topsoil will be segregated and stockpiled along the eastern edge of the pad. The stockpile will measure approximately 10 feet in height, and be staged at a ratio of 3:1.

4.2. Drilling and Completions

4.2.1. Protection of Soils

All stockpiled soils shall be protected from degradation due to contamination, compaction and, to the extent practicable, from wind and water erosion during drilling and production operations. BMPs to prevent weed establishment and to maintain soil microbial activity shall be implemented.

4.2.2. Weed Management

During normal operations and stormwater inspections, extraction employees and contractors will monitor the stockpile for erosion and establishment of undesirable and noxious weeds. Weeds will be treated mechanically with a mower whenever plant height exceeds 6 inches or before seed development. Chemical treatment of weeds with broad-leaf herbicides will only occur in spot-specific situations where prostrate weed growth or other site conditions preventing mechanical treatment are encountered. Soil sterilant and non-selective herbicides will not be used.

4.2.3. Maintenance & Repairs

Throughout all phases of development, any identified erosion will be repaired as soon as practicable, which is typically within 72 hours. Additional stormwater control measures will be deployed as needed. All deployed temporary stormwater control measures will be maintained and will remain in place until the disturbance achieves final stabilization as defined in the Colorado Department of Public Health and Environment (CDPHE) Water Quality Control Division COR400000 permit.

4.3. Interim Reclamation

When the Site enters the production phase of operations, areas no longer in use, totaling approximately 3.64 acres, will be interim reclaimed. Twelve (12) inches of topsoil will be redistributed throughout the interim reclamation area and contoured to match pre-disturbance topography. The redistributed soils will be tilled to adequately prepare the seedbed for seeding operations. Approximately 158,558 cubic feet (5,873 cubic yards) of total topsoil will be used during the interim reclamation phase.

4.3.1. Stockpile Management.

Prior to stockpile being adequately stabilized, perimeter sediment BMPs should be utilized to minimize any topsoil migration off site due to a rain event. Perimeter BMPs can be removed after stabilization is achieved. Once vegetation coverage begins, the stockpile should be mowed periodically to help promote even vegetative growth. Weeds should be removed if present. Soil sampling and chemical or mechanical remedies such as pH additives or aeration, respectively, may be needed if grass growth is not achieved during the growing season. Additional seeding might also be required to achieve widespread coverage.

4.3.2. Inspections

Inspection of BMPs shall occur for as long as they remain installed onsite. As per the CDPHE guidance, over the course of active construction, inspection shall occur every seven (7) days; or every fourteen

(14) days with post-storm inspections completed within 24 hours of precipitation accumulation or snow melt. When the construction site is considered idle, routine inspections must be performed minimally every 14 days and within 72 hours following storm events. When construction is complete and the Site is awaiting vegetative growth inspections shall be conducted once every 30 days. Please note post storm inspections are not required during this phase of construction. During all inspections, necessary repairs to BMPs will be noted and corrective action shall be immediately implemented. If noted deficiencies cannot be immediately addressed, the reasoning shall be noted and repair will be scheduled.

Topsoil will continue to be monitored during 30-day stormwater inspections conducted until the disturbance meets the 80% of reference area cover specified for achieving final stabilization under applicable stormwater CDPHE stormwater permit requirements. Topsoil protection, weed management and erosion control/repair will continue throughout the life of the Location per Colorado Oil and Gas Conservation Commission (COGCC) 1000 Series Rules.

5. SITE-SPECIFIC BMPS

Each of the BMPs listed below are intended for use at this site specifically (see Topsoil Protection Plan Exhibit in Appendix B). These BMPs are also consistent with the field-wide SWMP for Extraction. Detailed design and maintenance information for each BMP has been included as an attachment (Appendix C).

- Stockpile Management
 - Topsoil will be stockpiled along the southeastern edge of the proposed pad. In order to mitigate topsoil loss and migration of soil offsite, the stockpile will be contained using a perimeter erosion control device. Perimeter erosion controls will remain in place at any time the stockpile is not being actively accessed and until vegetative cover is established. Erosion control devices shall be placed within 5-10 feet of the toe of slope.
- Seeding
 - Once topsoil segregation and stockpiling are complete, the soil will be seeded with the specified seed mix (see Appendix D). Establishing vegetative cover will help to stabilize the soil, reduce wind and water erosion, minimize sheet flow and rill erosion, and reduce overall surface runoff. The stockpile will be regularly monitored for noxious weed growth. Re-seeding will occur as necessary, over the course of the project life in order to achieve wide spread, uniform vegetative cover.
- Mulching
 - Post seeding, a layer of straw or hay mulch will be installed via crimping along the stockpile, in order to promote seed germination and further stabilization of the soil. Mulching helps to mitigate the impacts of rainfall and increase soil moisture retention. Mulching will be monitored and re-applied as necessary, until vegetative growth is established.
- Filter Sock
 - Filter socks composed of excelsior, rocks, straw, coconut fibers, wood chips, or compost will be installed along the northern perimeter of the stormwater pond and the topsoil stockpiles. Erosion logs will aid in reducing flow velocities to mitigate rill erosion, and

capture sediment to mitigate runoff. Erosion control logs will remain in place until the pad is stabilized.

APPENDIX A
Soil Sample Photos

PHOTOS



1. PIB-1 Soil Test Pit Location



2. PIB-2 Soil Test Pit Location

PHOTOS



3. PIC-1 Soil Test Pit Location.



4. PIC-2 Soil Test Pit Location.

PHOTOS



5. UIC-1 Soil Test Pit Location.



6. UIC-2 Soil Test Pit Location.



7. UID-1 Soil Test Pit Location.



8. UID-2 Soil Test Pit

APPENDIX B

Topsoil Protection Plan Exhibit

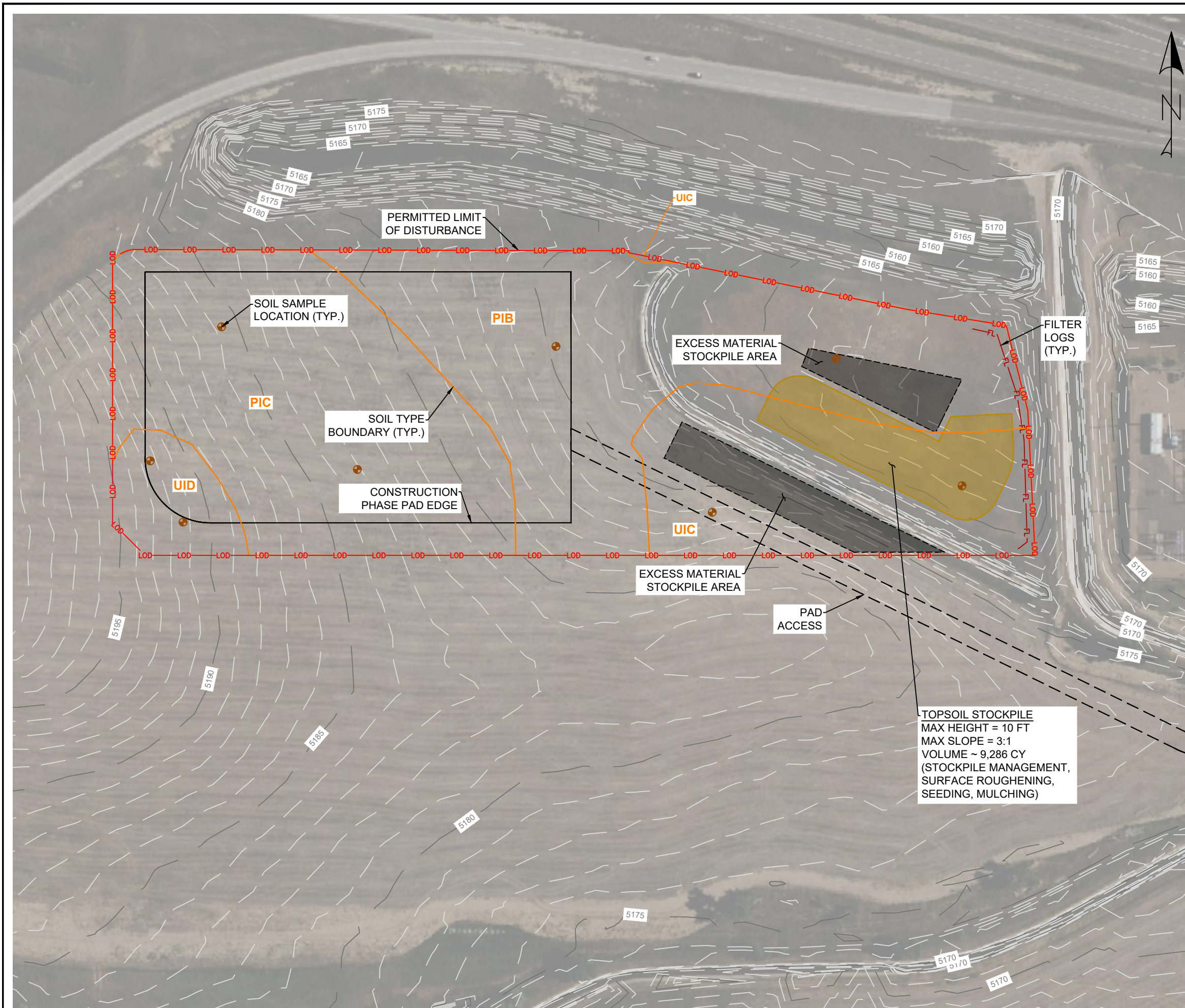

| MAP UNIT SYMBOL | MAP UNIT NAME | RATING | ACRES IN AOI | PERCENTAGE OF AOI |
|------------------------------------|---------------------------|--------|--------------|-------------------|
| PIB | PLANTER LOAM, 0-3% SLOPES | C | 5.6 | 39.5% |
| PIC | PLANTER LOAM, 3-5% SLOPES | C | 4.9 | 34.2% |
| UIC | ULM LOAM, 3-5% SLOPES | C | 3.0 | 21.3% |
| UID | ULM LOAM, 5-9% SLOPES | C | 0.7 | 4.9% |
| TOTALS FOR AREA OF INTEREST | | | 14.2 | 100% |

LEGEND

- 5100 EXISTING MAJOR CONTOUR
- EXISTING MINOR CONTOUR
- CONSTRUCTION PHASE PAD EDGE
- PAD ACCESS
- PERMITTED LIMIT OF DISTURBANCE
- FILTER LOGS
- TOPSOIL STOCKPILE
- EXCESS MATERIAL STOCKPILE
- SOIL UNIT BOUNDARY
- PIB** SOIL UNIT SYMBOL
- SOIL SAMPLE LOCATION

TOPSOIL STOCKPILE
 MAX HEIGHT = 10 FT
 MAX SLOPE = 3:1
 VOLUME ~ 9,286 CY
 (STOCKPILE MANAGEMENT,
 SURFACE ROUGHENING,
 SEEDING, MULCHING)

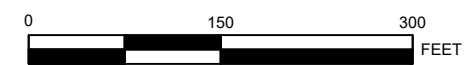

EXTRACTION OIL & GAS

DATE PREPARED: SEPTEMBER 2022

WASHINGTON PAD

| | |
|---------------------------------|--------|
| TOPSOIL MANAGEMENT PLAN EXHIBIT | 1 OF 1 |
|---------------------------------|--------|

APPENDIX C
BMP Datasheets

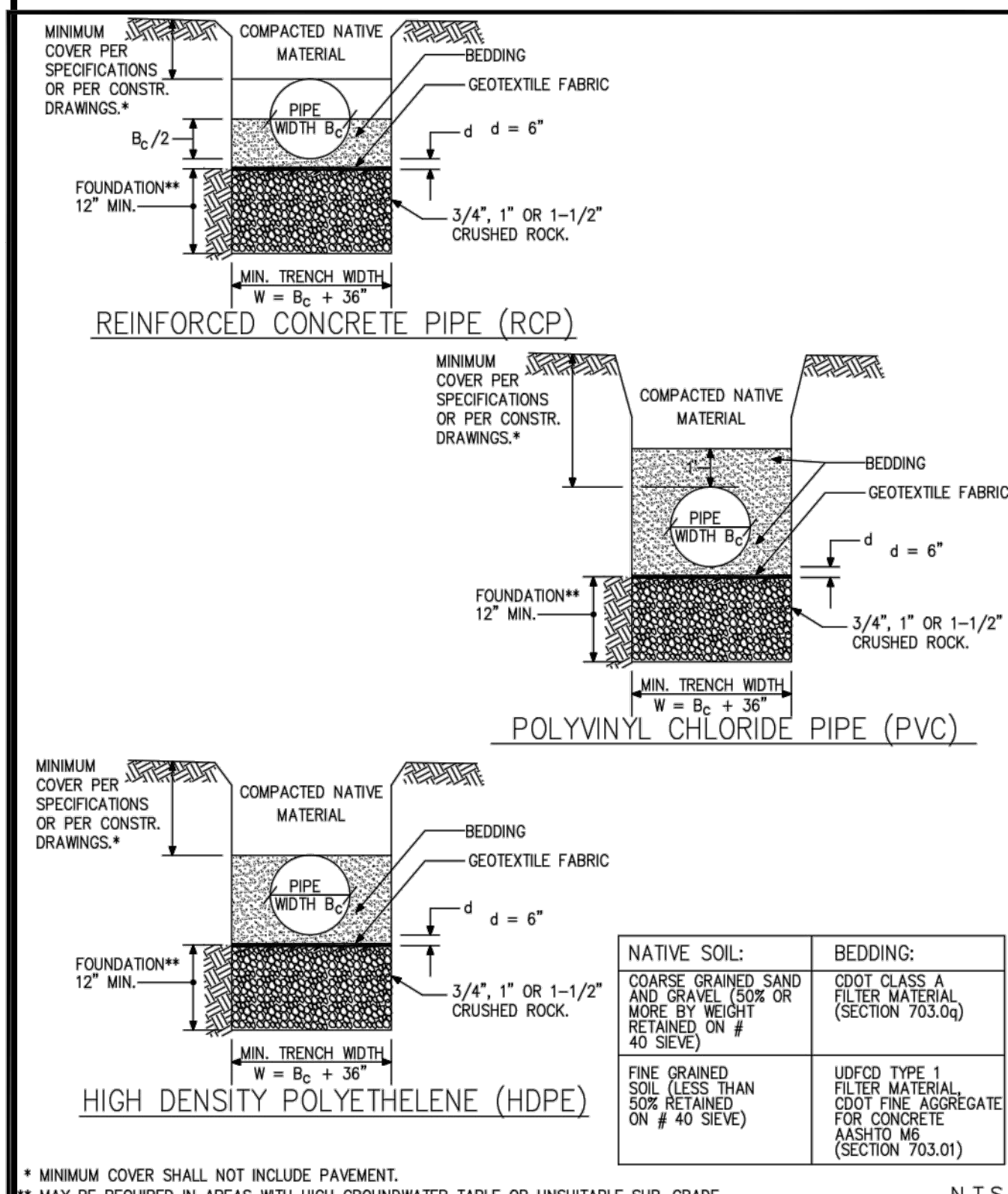

| | | |
|----------------------|--|--------------------------|
| | CITY OF THORNTON, COLORADO STANDARDS & SPECIFICATIONS STORM DRAINAGE PIPE BEDDING DETAILS | ISSUED: DECEMBER 2002 |
| | | REVISOR: APRIL 2010 |
| DRAWING NO. 400-2 | | N.T.S. |

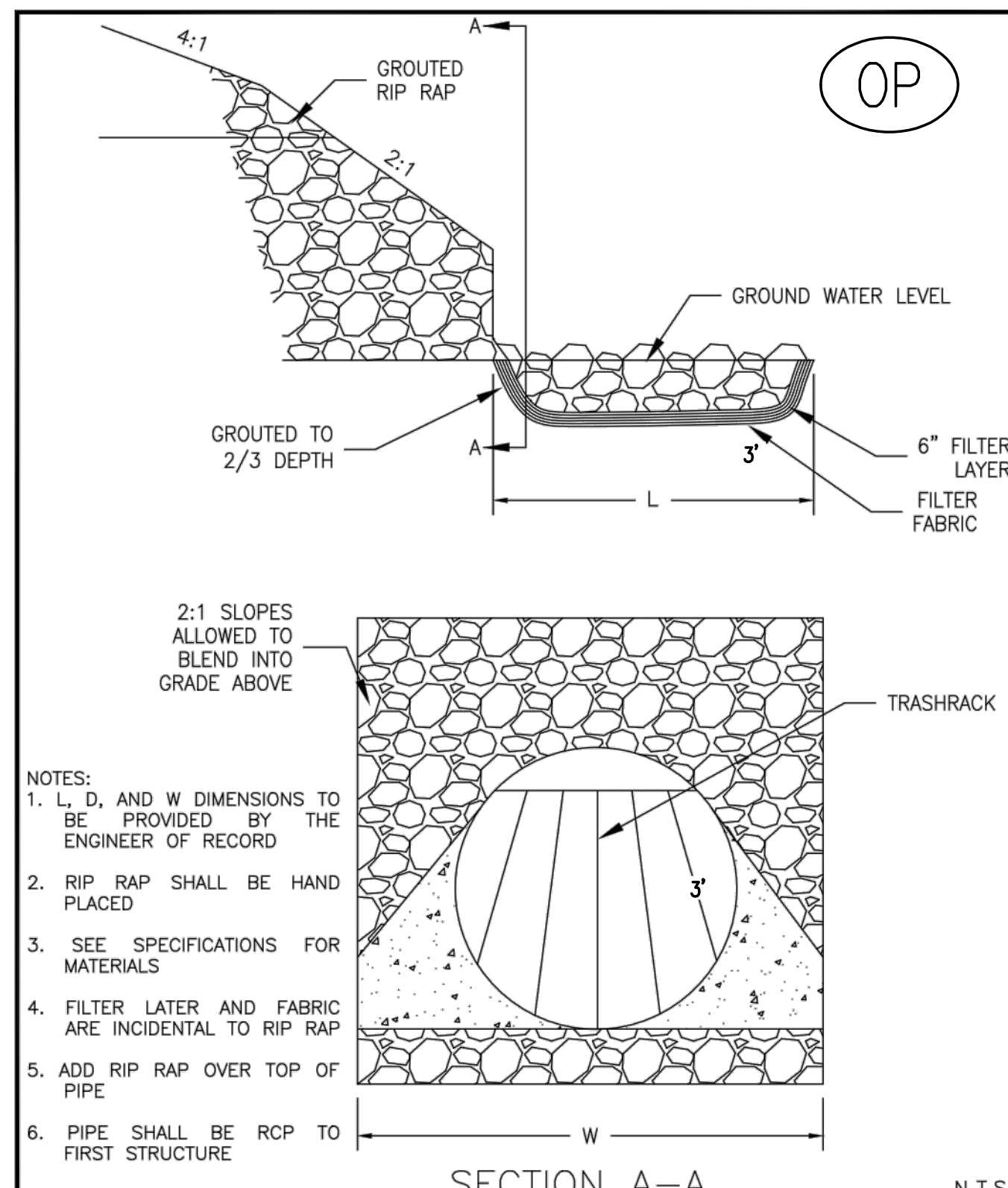

| | | |
|----------------------|---|------------------------|
| | CITY OF THORNTON, COLORADO STANDARDS & SPECIFICATIONS RIP RAP AT CULVERT OUTLET DETAIL | ISSUED: APRIL 1995 |
| | | REVISOR: APRIL 2010 |
| DRAWING NO. 400-4 | | N.T.S. |

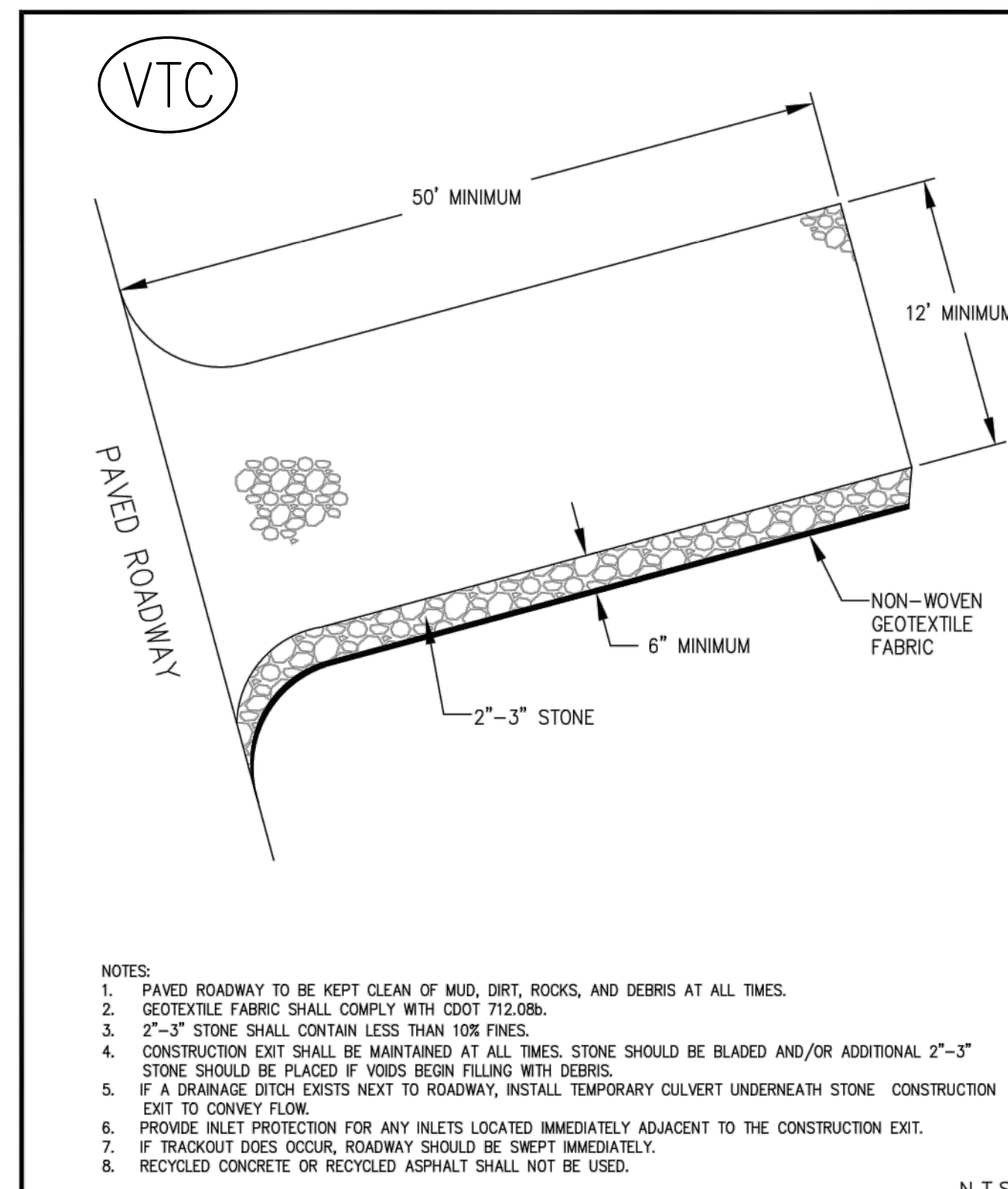

| | | |
|----------------------|---|-------------------|
| | CITY OF THORNTON, COLORADO STANDARDS & SPECIFICATIONS VEHICLE TRACKING PAD | ISSUED: NOV 08 |
| | | REVISOR: |
| DRAWING NO. 400-7 | | N.T.S. |

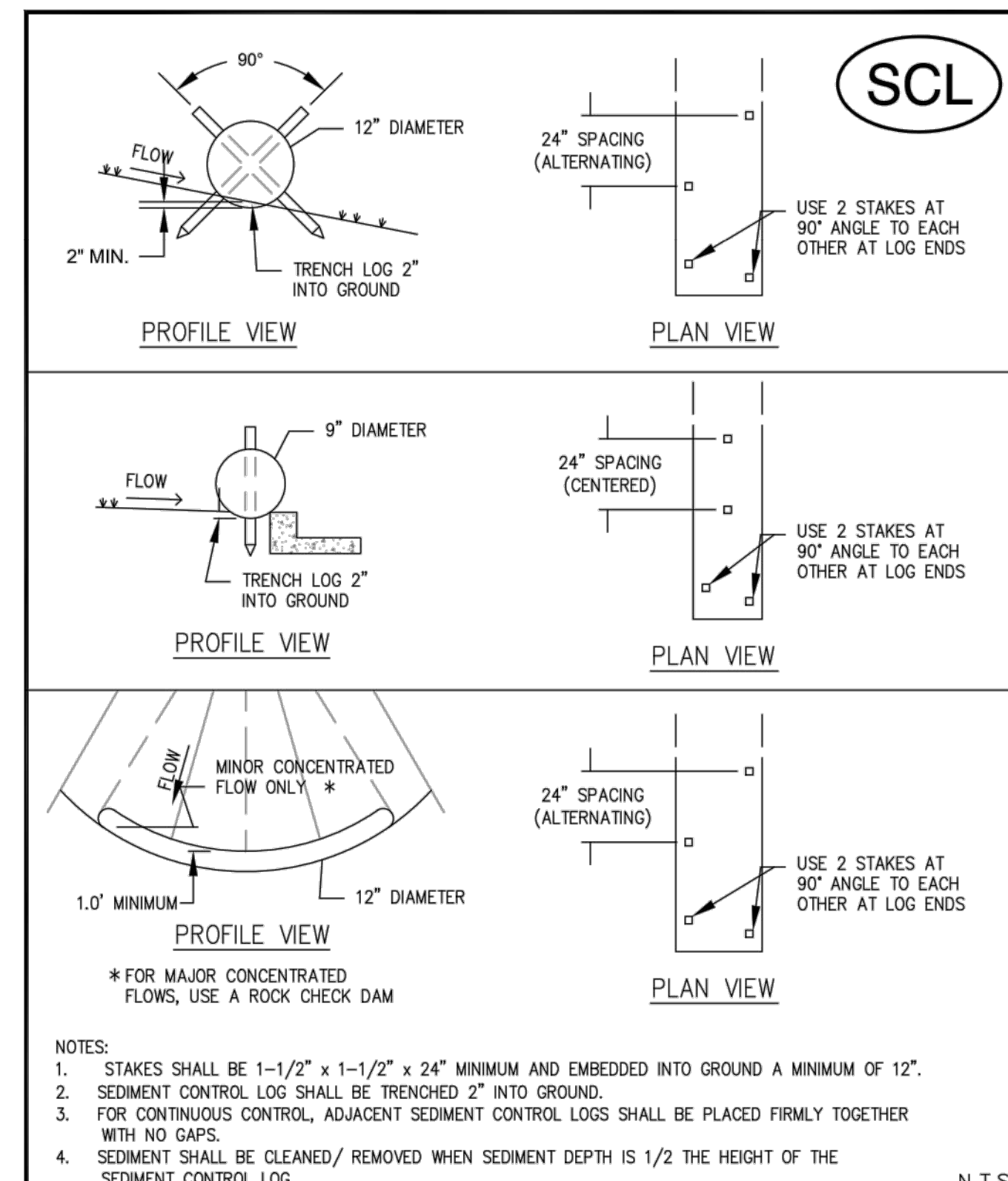

| | | |
|----------------------|---|-------------------|
| | CITY OF THORNTON, COLORADO STANDARDS & SPECIFICATIONS SEDIMENT CONTROL LOG | ISSUED: NOV 08 |
| | | REVISOR: |
| DRAWING NO. 400-9 | | N.T.S. |

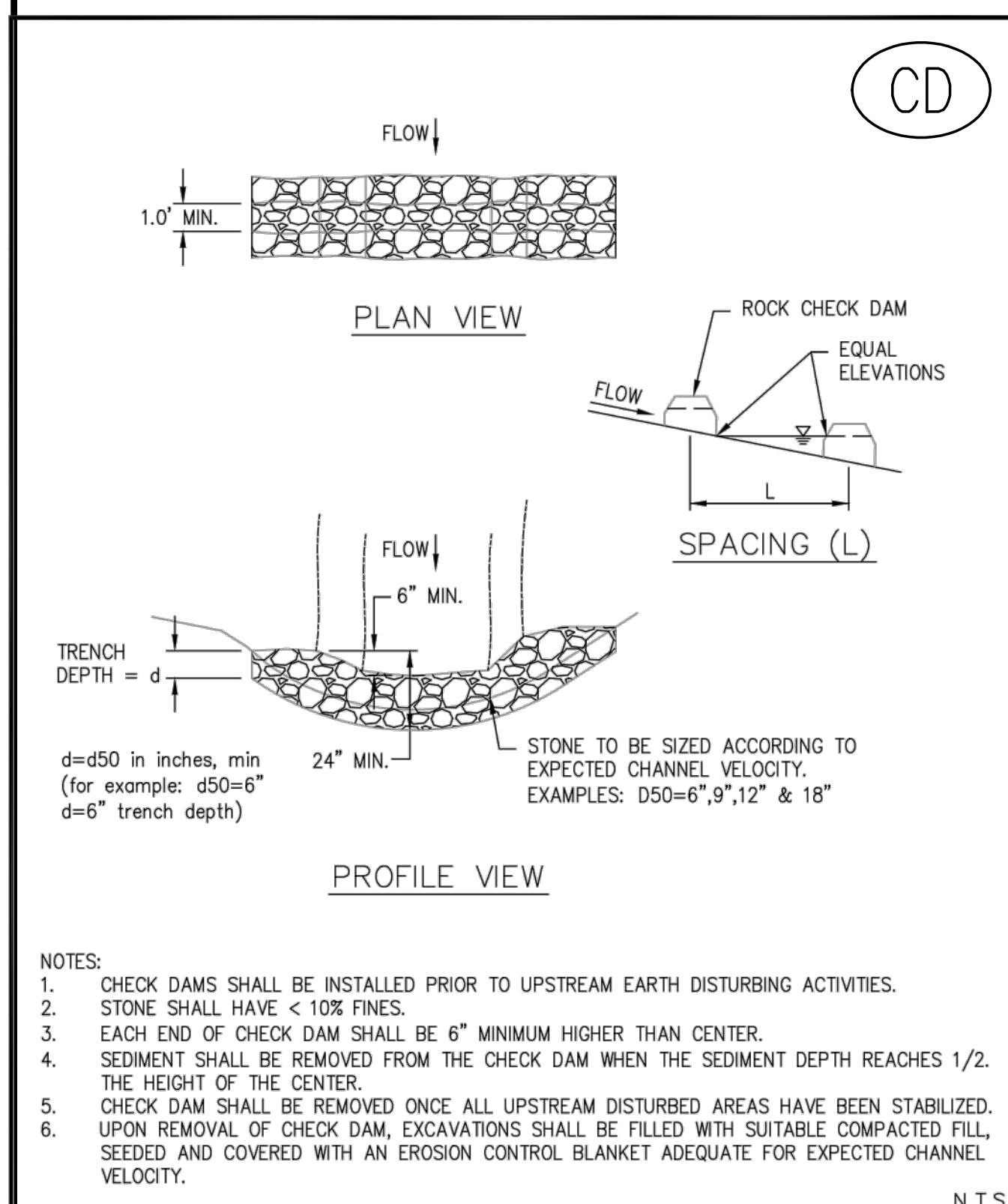

| | | |
|-----------------------|--|-------------------|
| | CITY OF THORNTON, COLORADO STANDARDS & SPECIFICATIONS CHECK DAM | ISSUED: NOV 08 |
| | | REVISOR: |
| DRAWING NO. 400-11 | | N.T.S. |

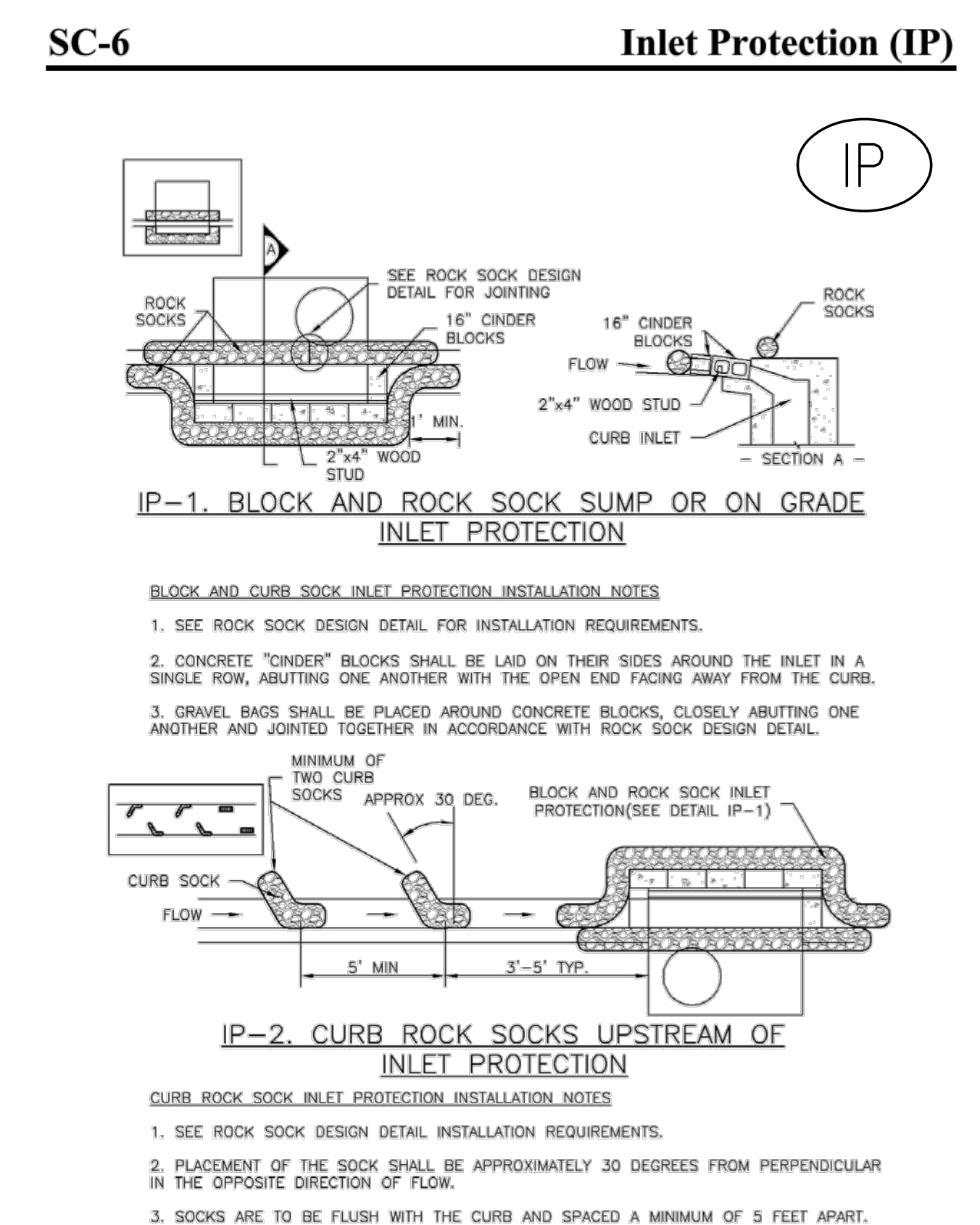

| | | |
|-----------------------|--|-------------------|
| | CITY OF THORNTON, COLORADO STANDARDS & SPECIFICATIONS IP-1. BLOCK AND ROCK SOCK SUMP OR ON GRADE INLET PROTECTION | ISSUED: NOV 08 |
| | | REVISOR: |
| DRAWING NO. 400-11 | | N.T.S. |

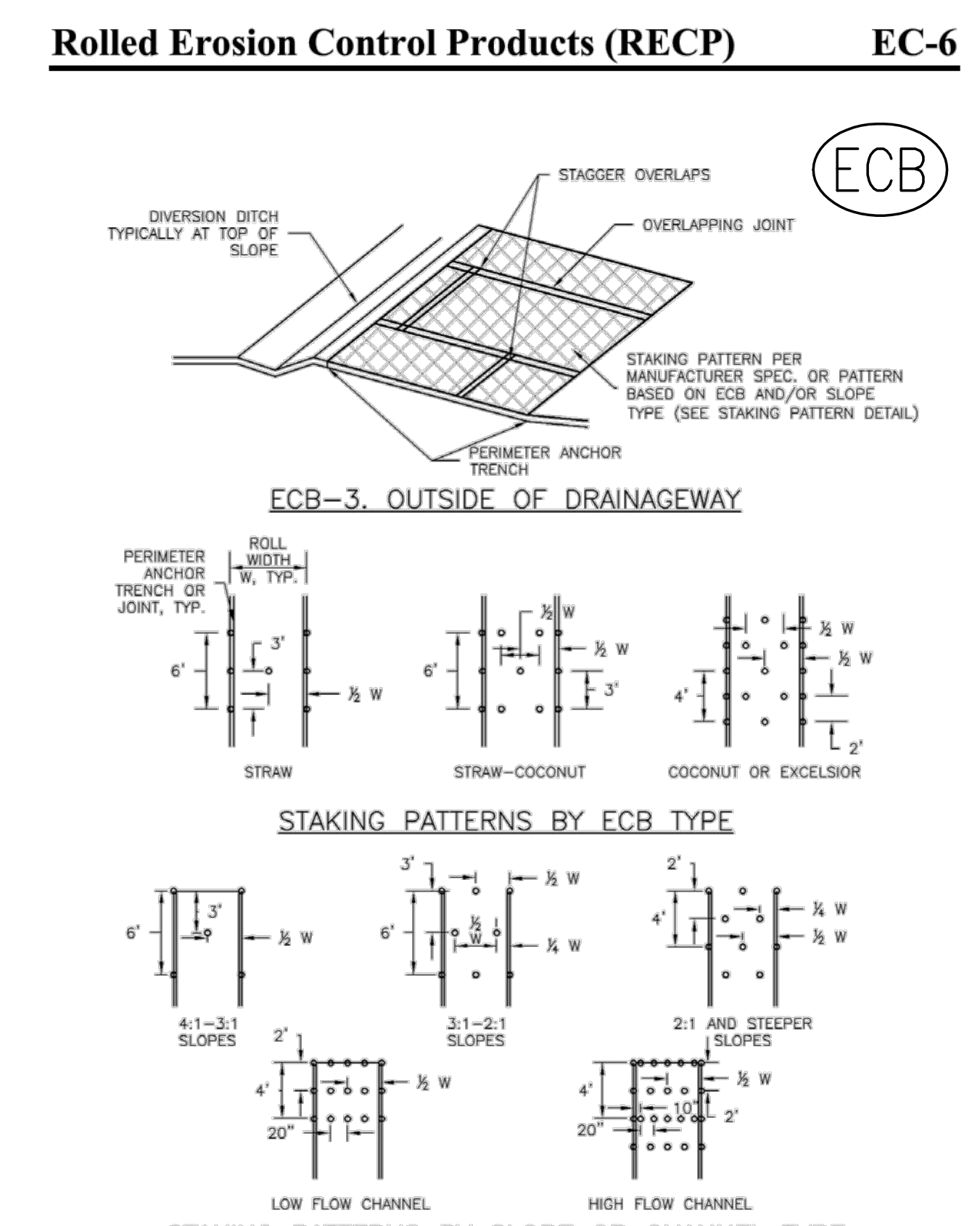

| | | |
|----------------------|--|-------------------|
| | CITY OF THORNTON, COLORADO STANDARDS & SPECIFICATIONS ECB-3. OUTSIDE OF DRAINAGEWAY | ISSUED: NOV 08 |
| | | REVISOR: |
| DRAWING NO. 400-7 | | N.T.S. |

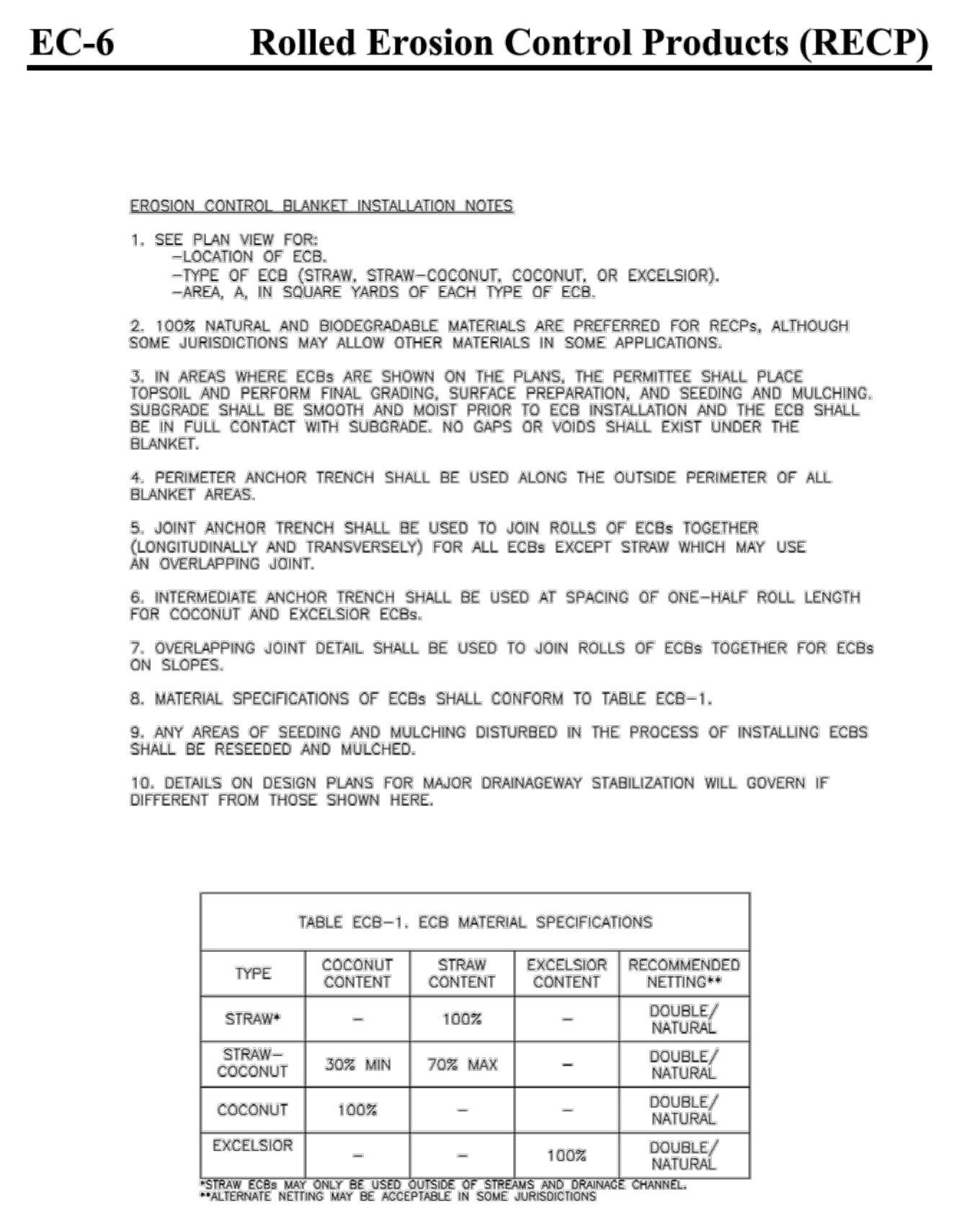

| | | |
|----------------------|--|-------------------|
| | CITY OF THORNTON, COLORADO STANDARDS & SPECIFICATIONS ECB-6. ROLLED EROSION CONTROL PRODUCTS (RECP) | ISSUED: NOV 08 |
| | | REVISOR: |
| DRAWING NO. 400-7 | | N.T.S. |

BASELINE
Engineering • Planning • Surveying
112 W. RUBEY DRIVE, SUITE 210 • GOLDEN, COLORADO 80401
P: 303.428.8668 • F: 303.428.8669 • www.baselinecorp.com

DESIGNED BY: JDD
DRAWN BY: JDD
CHECKED BY: LOS

PREPARED BY: DATE

REVISION DESCRIPTION

ADAMS COUNTY
WASHINGTON PAD
SOUTHEAST QUARTER OF SECTION 10, TOWNSHIP 1 SOUTH, RANGE 68 WEST
EROSION AND SEDIMENT CONTROL DETAILS

CITY OF THORNTON

FOR AND ON BEHALF OF
BASELINE CORPORATION
PRELIMINARY
NOT FOR
CONSTRUCTION

INITIAL SUBMITTAL: 05/25/2022
DRAWING SIZE: 22" x 34"
SURVEY FIRM: SURVEY DATE: 02/25/2022
JOB NO.: EXT01568W10-02
DRAWING NAME: 11MS2.dwg
SHEET: 11 OF 27

FOR AND ON BEHALF OF
BASELINE CORPORATION
November 2010
Urban Drainage and Flood Control District
Urban Storm Drainage Criteria Manual Volume 3
RECP-7

November 2010
Urban Drainage and Flood Control District
Urban Storm Drainage Criteria Manual Volume 3
RECP-8

November 2010
Urban Drainage and Flood Control District
Urban Storm Drainage Criteria Manual Volume 3
RECP-6

M:\co - Well Head Staking\EXT01568W10-02 (WASHINGTON W)\Drawings\Construction Documents\North\DET\AL2.dwg, 6/7/15/2022 5:29:56 PM, Jay Davis

Surface Roughening (SR)

EC-1

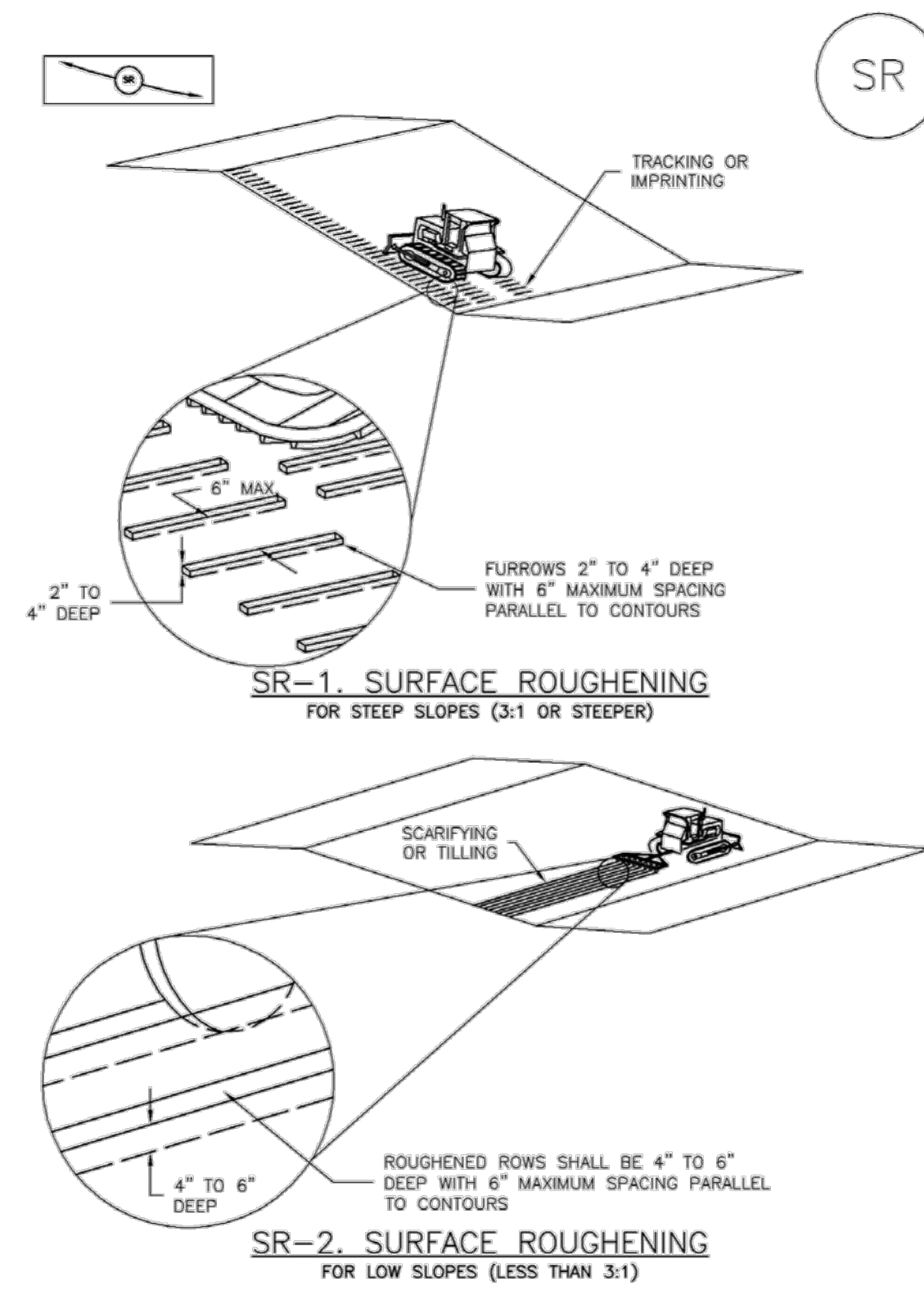

EC-1

Surface Roughening (SR)

SURFACE ROUGHENING INSTALLATION NOTES

- SEE PLAN VIEW FOR:
-LOCATION(S) OF SURFACE ROUGHENING.
- SURFACE ROUGHENING SHALL BE PROVIDED PROMPTLY AFTER COMPLETION OF FINISHED GRADING (FOR AREAS NOT RECEIVING TOPSOIL) OR PRIOR TO TOPSOIL PLACEMENT OR ANY FORECASTED RAIN EVENT.
- AREAS WHERE BUILDING FOUNDATIONS, PAVEMENT, OR SOD WILL BE PLACED WITHOUT DELAY IN THE CONSTRUCTION SEQUENCE, SURFACE ROUGHENING IS NOT REQUIRED.
- DISTURBED SURFACES SHALL BE ROUGHENED USING RIPPING OR TILLING EQUIPMENT ON THE CONTOUR OR TRACKING UP AND DOWN A SLOPE USING EQUIPMENT TREADS.
- A FARMING DISK SHALL NOT BE USED FOR SURFACE ROUGHENING.

SURFACE ROUGHENING MAINTENANCE NOTES

- INSPECT BMPs EACH WORKDAY, AND MAINTAIN THEM IN EFFECTIVE OPERATING CONDITION. MAINTENANCE OF BMPs SHOULD BE PROACTIVE, NOT REACTIVE. INSPECT BMPs AS SOON AS POSSIBLE (AND ALWAYS WITHIN 24 HOURS) FOLLOWING A STORM THAT CAUSES SURFACE EROSION, AND PERFORM NECESSARY MAINTENANCE.
- FREQUENT OBSERVATIONS AND MAINTENANCE ARE NECESSARY TO MAINTAIN BMPs IN EFFECTIVE OPERATING CONDITION. INSPECTIONS AND CORRECTIVE MEASURES SHOULD BE DOCUMENTED THOROUGHLY.
- WHERE BMPs HAVE FAILED, REPAIR OR REPLACE UPON DISCOVERY OF THE FAILURE.
- VEHICLES AND EQUIPMENT SHALL NOT BE DRIVEN OVER AREAS THAT HAVE BEEN SURFACE ROUGHENED.
- IN NON-TURF GRASS FINISHED AREAS, SEEDING AND MULCHING SHALL TAKE PLACE DIRECTLY OVER SURFACE ROUGHENED AREAS WITHOUT FIRST SMOOTHING OUT THE SURFACE.
- IN AREAS NOT SEEDED AND MULCHED AFTER SURFACE ROUGHENING, SURFACES SHALL BE RE-ROUGHENED AS NECESSARY TO MAINTAIN GROOVE DEPTH AND SMOOTH OVER RILL EROSION.

(DETAILS ADAPTED FROM TOWN OF PARKER, COLORADO, NOT AVAILABLE IN AUTOCAD)

NOTE: MANY JURISDICTIONS HAVE BMP DETAILS THAT VARY FROM UDFCD STANDARD DETAILS. CONSULT WITH LOCAL JURISDICTIONS AS TO WHICH DETAIL SHOULD BE USED WHEN DIFFERENCES ARE NOTED.

November 2010 Urban Drainage and Flood Control District SR-3
Urban Storm Drainage Criteria Manual Volume 3

SR-4 Urban Drainage and Flood Control District November 2010
Urban Storm Drainage Criteria Manual Volume 3

Mulching (MU)

EC-4

Description

Mulching consists of evenly applying straw, hay, shredded wood mulch, rock, bark or compost to disturbed soils and securing the mulch by crimping, tackifiers, netting or other measures. Mulching helps reduce erosion by protecting bare soil from rainfall impact, increasing infiltration, and reducing runoff. Although often applied in conjunction with temporary or permanent seeding, it can also be used for temporary stabilization of areas that cannot be reseeded due to seasonal constraints.



Photograph MU-1. An area that was recently seeded, mulched, and crimped.

Mulch can be applied either using standard mechanical dry application methods or using hydromulching equipment that hydraulically applies a slurry of water, wood fiber mulch, and often a tackifier.

Appropriate Uses

Use mulch in conjunction with seeding to help protect the seedbed and stabilize the soil. Mulch can also be used as a temporary cover on low to mild slopes to help temporarily stabilize disturbed areas where growing season constraints prevent effective reseeding. Disturbed areas should be properly mulched and tacked, or seeded, mulched and tacked promptly after final grade is reached (typically within no longer than 14 days) on portions of the site not otherwise permanently stabilized.

Standard dry mulching is encouraged in most jurisdictions; however, hydromulching may not be allowed in certain jurisdictions or may not be allowed near waterways.

Do not apply mulch during windy conditions.

Design and Installation

Prior to mulching, surface-roughen areas by rolling with a crimping or punching type roller or by track walking. Track walking should only be used where other methods are impractical because track walking with heavy equipment typically compacts the soil.

A variety of mulches can be used effectively at construction sites. Consider the following:

| Mulch | |
|--------------------------|----------|
| Functions | |
| Erosion Control | Yes |
| Sediment Control | Moderate |
| Site/Material Management | No |

June 2012 Urban Drainage and Flood Control District MU-1
Urban Storm Drainage Criteria Manual Volume 3

EC-4

Mulching (MU)

- Clean, weed-free and seed-free cereal grain straw should be applied evenly at a rate of 2 tons per acre and must be tacked or fastened by a method suitable for the condition of the site. Straw mulch must be anchored (and not merely placed) on the surface. This can be accomplished mechanically by crimping or with the aid of tackifiers or nets. Anchoring with a crimping implement is preferred, and is the recommended method for areas flatter than 3:1. Mechanical crimpers must be capable of tucking the long mulch fibers into the soil to a depth of 3 inches without cutting them. An agricultural disk, while not an ideal substitute, may work if the disk blades are dull or blunted and set vertically; however, the frame may have to be weighted to afford proper soil penetration.
- Grass hay may be used in place of straw; however, because hay is comprised of the entire plant including seed, mulching with hay may seed the site with non-native grass species which might in turn out-compete the native seed. Alternatively, native species of grass hay may be purchased, but can be difficult to find and are more expensive than straw. Purchasing and utilizing a certified weed-free straw is an easier and less costly mulching method. When using grass hay, follow the same guidelines as for straw (provided above).
- On small areas sheltered from the wind and heavy runoff, spraying a tackifier on the mulch is satisfactory for holding it in place. For steep slopes and special situations where greater control is needed, erosion control blankets anchored with stakes should be used instead of mulch.
- Hydraulic mulching consists of wood cellulose fibers mixed with water and a tackifying agent and should be applied at a rate of no less than 1,500 pounds per acre (1,425 lbs of fibers mixed with at least 75 lbs of tackifier) with a hydraulic mulcher. For steeper slopes, up to 2000 pounds per acre may be required for effective hydroseeding. Hydromulch typically requires up to 24 hours to dry; therefore, it should not be applied immediately prior to inclement weather. Application to roads, waterways and existing vegetation should be avoided.
- Erosion control mats, blankets, or nets are recommended to help stabilize steep slopes (generally 3:1 and steeper) and waterways. Depending on the product, these may be used alone or in conjunction with grass or straw mulch. Normally, use of these products will be restricted to relatively small areas. Biodegradable mats made of straw and jute, straw-coconut, coconut fiber, or excelsior can be used instead of mulch. (See the ECM/TRM BMP for more information.)
- Some tackifiers or binders may be used to anchor mulch. Check with the local jurisdiction for allowed tackifiers. Manufacturer's recommendations should be followed at all times. (See the Soil Binder BMP for more information on general types of tackifiers.)
- Rock can also be used as mulch. It provides protection of exposed soils to wind and water erosion and allows infiltration of precipitation. An aggregate base course can be spread on disturbed areas for temporary or permanent stabilization. The rock mulch layer should be thick enough to provide full coverage of exposed soil on the area it is applied.

Maintenance and Removal

After mulching, the bare ground surface should not be more than 10 percent exposed. Reapply mulch, as needed, to cover bare areas.

MU-2 Urban Drainage and Flood Control District June 2012
Urban Storm Drainage Criteria Manual Volume 3

BASELINE
Engineering • Planning • Surveying
112 W. RUBEY DRIVE, SUITE 210 • GOLDEN, COLORADO 80403
P: 303.540.8666 • F: 303.540.8669 • www.baselinecorp.com

| DESIGNED BY | DATE |
|-------------|------|
| JDD | |
| DRAWN BY | DATE |
| JDD | |
| CHECKED BY | DATE |
| LDS | |

EXTRACTION OIL & GAS
ADAMS COUNTY
WASHINGTON PAD
CITY OF THORNTON
SOUTHEAST QUARTER OF SECTION 10, TOWNSHIP 1 SOUTH, RANGE 68 WEST
EROSION AND SEDIMENT CONTROL DETAILS

FOR AND ON BEHALF OF
BASELINE CORPORATION
INITIAL SUBMITTAL 05/25/2022
DRAWING SIZE 22" x 34"
SURVEY FIRM SURVEY DATE
BASELINE 02/25/2022
JOB NO. EXT01568W10-02
DRAWING NAME
EXT01568W10-02
SHEET 12 OF 27
11.12

**PRELIMINARY
NOT FOR
CONSTRUCTION**

M:\co - Well Head Staking\EXT01568W10-02 (WASHINGTON W)\Drawings\Construction Documents\North\DETAILS2.dwg, 6/7/15/2022 5:30:00 PM, Jay Davis

APPENDIX D
Seed Mix

Seed Mix

| Common Name | Scientific Name | Variety | # Pure Live Seed/Acre | Percent of Mix |
|--------------------|--------------------------------|---------|-----------------------|----------------|
| Blue grama | <i>Bouteloua gracilis</i> | Native | 0.42 | 20 |
| Sideoats grama | <i>Bouteloua curtipendula</i> | Vaughn | 1.37 | 15 |
| Buffalograss | <i>Bouteloua dactyloides</i> | Native | 4.67 | 15 |
| Western wheatgrass | <i>Pascopyrum smithii</i> | Native | 1.98 | 12.5 |
| Western wheatgrass | <i>Pascopyrum smithii</i> | Arriba | 1.98 | 12.5 |
| Green needlegrass | <i>Nassella viridula</i> | Lodorm | 1.16 | 12 |
| Little bluestem | <i>Schizachyrium scoparium</i> | Native | 0.87 | 13 |
| | Total | | 12.45 | 100 |

Seeding and Amendments

Note: The seed mix may be adjusted based on landowner preference, seeding dates, or other variables. Adjustments to the seed mix are not expected to warrant significant adjustments to the cost or schedule of reclamation. Fall/winter seeding and amendment applications are recommended to optimize dormancy and moisture conditions for suitable winter- spring germination and growth. Planting of native species between May and September will not favor planted grasses, for example, and may encourage weed growth through surface disturbance.

In the Fall/Winter/Spring:

- Apply 40lbs/acre of slow release nitrogen to the well/facility pad and access road to account for the less than optimal nitrate levels present.
- Following or concurrent with amendment application, drill-seed reclamation area with the seed mix specified.
- Crimp reclamation area with two (2) tons/acre certified weed-free straw after seeding