

Lighting Mitigation Plan

For



Garnet 21-K Pad

Project Number: 21282

Originators:	<u>L. Ohl</u>	Date	<u>11-04-2021</u>
Project Engineer Approval:	<u>R. Morris</u>	Date	<u>11-04-2021</u>
Project Manager Approval:	<u>B. Primeaux</u>	Date	<u>11-04-2021</u>
Client Review:	<u>M. Brown</u>	Date	<u>11-04-2021</u>

Rev. No.	By	Revisions	Approval	Date
0	LO	Issued for Attachment to Permit	BP	4-13-2022

TABLE OF CONTENTS

1.0 EXECUTIVE SUMMARY..... 3

2.0 INTRODUCTION AND DEFINITION OF TECHNICAL TERMS..... 4

 2.1 INTRODUCTION 4

 2.2 DEFINITION OF TECHNICAL TERMS 4

3.0 MODEL AND ANALYSIS DEVELOPMENT 5

4.0 LIGHTING ANALYSIS RESULTS..... 6

 4.1 CUMULATIVE LIGHTING IMPACTS..... 6

 4.2 HARDSCAPE VS LUMEN LEVEL RESULTS..... 8

 4.2.1 Pre-Production Drilling Hardscape per Lumens Compliance 9

 4.2.2 Pre-Production Completions Hardscape per Lumens Compliance 9

 4.2.3 Production Hardscape per Lumens Compliance 10

5.0 SITE LIGHTING POSITIONS AND ORIENTATION 11

 5.1 SITE LIGHTING NOTES..... 11

 5.2 PRE-PRODUCTION - DRILLING SITE LAYOUT AND LUMINAIRE SCHEDULE..... 12

 5.3 PRE-PRODUCTION - DRILLING - DETAIL A - SITE LAYOUT AND LUMINAIRE SCHEDULE 14

 5.4 PRE-PRODUCTION - DRILLING - DETAIL B - SITE LAYOUT AND LUMINAIRE SCHEDULE 16

 5.5 PRE-PRODUCTION - COMPLETIONS - SITE LAYOUT AND LUMINAIRE SCHEDULE. 19

 5.6 PRODUCTION - SITE LAYOUT, LUMINAIRE SCHEDULE, AND PHOTOMETRIC..... 21

6.0 SITE MITIGATION NOTES AND TECHNIQUES 25

7.0 ATTACHMENTS..... 26

1.0 EXECUTIVE SUMMARY

Bayswater commissioned Samuel Engineering to develop a lighting mitigation plan for the Garnet 21-K Pad site. The purpose of this report is to demonstrate compliance with the various State and Local lighting regulations, predict the lighting impacts of the different development phases, and to detail the various lighting mitigation techniques that were implemented.

The key points of the study are:

- Demonstrate compliance with Colorado Oil and Gas Conservation Commission (COGCC) Rule 424 and Weld County Regulations.
- Identify the light level impacts associated with each phase of the facility operations on surrounding buildings.
- Demonstrate compliance with the total lighting used based on site working surfaces.
- Demonstrate the various lighting mitigation techniques that were implemented to reduce lighting pollution.

Site specific three-dimensional lighting models were developed for each of the phases to determine their associated lighting impacts. The lighting fixtures used in the models were selected based on currently operated representative sites and research conducted into available vendor lighting systems.

The following Table 1.0 summarizes the calculated findings of this report compared to the regulatory limits:

Calculated Lighting Values vs. Regulatory Limits Summary			
	Calculated Value	Regulatory Limit	Code Reference
Max. Light Impact on Surrounding Building	0.18 lux	=< 4.0 lux	<i>COGCC 424.f</i>
Pre-Production – Drilling Phase (Lumens / Hardscape)	4.1 lm/ft ²	=< 12 lm/ft ²	<i>Weld County Ordinance ORD2020-12 Table 405 B.1</i>
Pre-Production – Completions Phase (Lumens / Hardscape)	2.0 lm/ft ²	=< 12 lm/ft ²	<i>Weld County Ordinance ORD2020-12 Table 405 B.1</i>
Production (Lumens / Hardscape)	0.5 lm/ft ²	=< 2.5 lm/ ft ²	<i>Weld County Sec 21-5-405 Table 405.C.1 for land use LZ-2 and COGCC Rule 424.d.(2) for Agricultural/Commercial</i>

Table 1.0 - Calculated Lighting Values vs. Regulatory Limits

As shown, all calculated values fall within their prescribed regulatory limits.

2.0 INTRODUCTION AND DEFINITION OF TECHNICAL TERMS

2.1 INTRODUCTION

Light mitigation plans seek to quantify and prescribe methods to address the negative effects of multiple forms of light pollution. Effective mitigation plans address light pollution by limiting the impacts on the surrounding communities, preserving the overall night-sky aesthetics, and maintaining existing ecosystems, all while maintaining a safe work environment.

There are a number of standards, best practices, and regulations which are used as guidelines when developing lighting plans for reducing the negative effects of artificial lighting. The applicable regulations used for this report are COGCC Rule 424 and Weld County Ordinance ORD2020-12.

2.2 DEFINITION OF TECHNICAL TERMS

A number of technical terms are used throughout this report and, as an aid to the reader, are defined below.

Illuminance (lx)

Illuminance is defined as the amount of light falling on a surface area. It is measured in Lux (lx). One lux is equal to one lumen per square meter. As an example, the photo in Figure 2.2 shows the lux levels decreasing on the sidewalk, as the distance from the light source increases.

Illuminance is often associated with values for lighting levels for safe operation in various standard codes. In addition, photometric plans are used to predict the illuminance on surfaces of an area to provide minimum lighting levels and for mitigation of light trespass into adjoining properties or areas. Most lighting meter units used today are in lux and used to measure these values at a given distance. It should be noted that the measured value is dependent on angle, sensitivity, and optics.

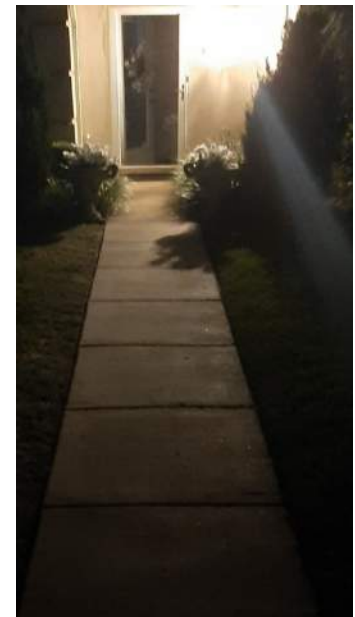

Figure 2.2 – Illuminance (lx) level decreasing with distance from light source.

Table 2.2 below provides examples of typical Lux values.

Example Lux Values	
Clear night, no moon:	0.002 lx
Clear night, full Moon:	0.27-1 lx
Family Living Room	50 lx
Sunrise/sunset	300-500 lx
Overcast day:	1000 lx
Daylight:	10000-25000 lx
Direct sunlight:	32000-130000 lx

Table 2.2 – Example Lux Values

Luminous Flux (lm)

Luminous Flux is defined as the amount of light energy produced per unit time and is measured in Lumens (lm). It is a physical property of light and, in general terms, is a measurement of the total amount of light emanating from a source. It is important to note that the luminous flux value of a given source is independent of where a measurement is taken.

For example, a 60-watt light bulb produces approximately 800 lumens, regardless of if the measurement is taken at 1 foot, 10 miles, or 10,000 miles away from the source.

3.0 MODEL AND ANALYSIS DEVELOPMENT

Site-specific three-dimensional models were developed for each of the major project development phases. These phases being Pre-Production Drilling, Pre-Production Completions, and final Production. Elements incorporated into the models, among others, were the local site topographical information, major lighting obstructions (sound wall, large equipment, etc), individual luminaire lighting qualities, lighting mounting characteristics and surrounding building units.

The site geographical information was obtained using USGS topographical information to model the surrounding 1-mile landscape.

To determine the lighting impacts on local building units, 25-foot vertical walls were modeled at the unit’s locations, at the USGS identified elevations.

Modeling of site-specific information (including large equipment, type of luminaire, and sound wall locations)

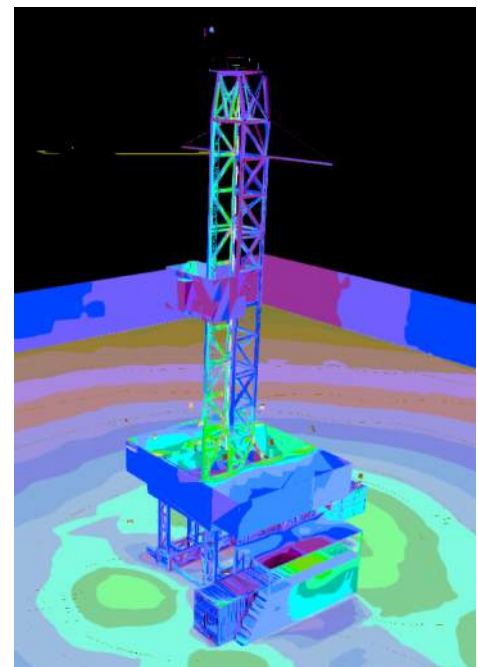

Figure 3.0 – Screenshot from an example 3-D model showing a false color rendering

were based on inspections of operational representative sites, provided vendor information, and research into various available lighting systems. The major pieces of equipment modeled included:

- Drilling: Drill rig floor, derrick, substructure, temporary lighting, sound barriers, backyard, and trailers.
- Completions: Temporary lighting, sound barriers, completions fleet equipment, and trailers.
- Production: LACT skids, separators, large tanks, and associated equipment.

Once site-specific topographical information and equipment were modeled, lighting characteristics were placed within the model. These characteristics were obtained from the various manufacturers and were specific to the make/model of the light to be used. The luminaire information included in the model were the type, quantity, mounting height, orientation, and tilt angle.

Models for each of the various project phases were developed in a similar manner and the resulting calculated lighting impacts were tabulated. An Excel spreadsheet was used to total the site lumens for each fixture and compare it to the site working pad surface (hardscape).

In the Pre-Production phases, temporary lighting fixtures were based on currently available rental units and on observations from representative sites. The temporary lighting system that will be used might vary based on rental availability at the time of procurement but is expected to be representative of the lumen values used in this analysis.

4.0 LIGHTING ANALYSIS RESULTS

4.1 CUMULATIVE LIGHTING IMPACTS

Applicable Code Reference: COGCC Rule 424.f:

“Operators will develop site lighting to reduce cumulative nighttime light intensity from all Oil and Gas Facilities to 4 lux at any Residential Building Unit or High Occupancy Building Unit within 1 mile of any Oil and Gas Facility, measured at 5.5 feet above grade in a direct line of sight to the brightest light fixture onsite.”

Due to the large number of buildings units located within the 1-mile radius of the site, buildings were grouped into clusters and a representative "wall" location was selected for analysis. These analyzed "wall" locations were selected to determine an upper cumulative light impact limit for that clustered group, taking into account the local topography, orientation, and distance to the site.

Figure 4.1 shows the residential building units that are located within a 1-mile radius of the Garnet 21-K Pad site.

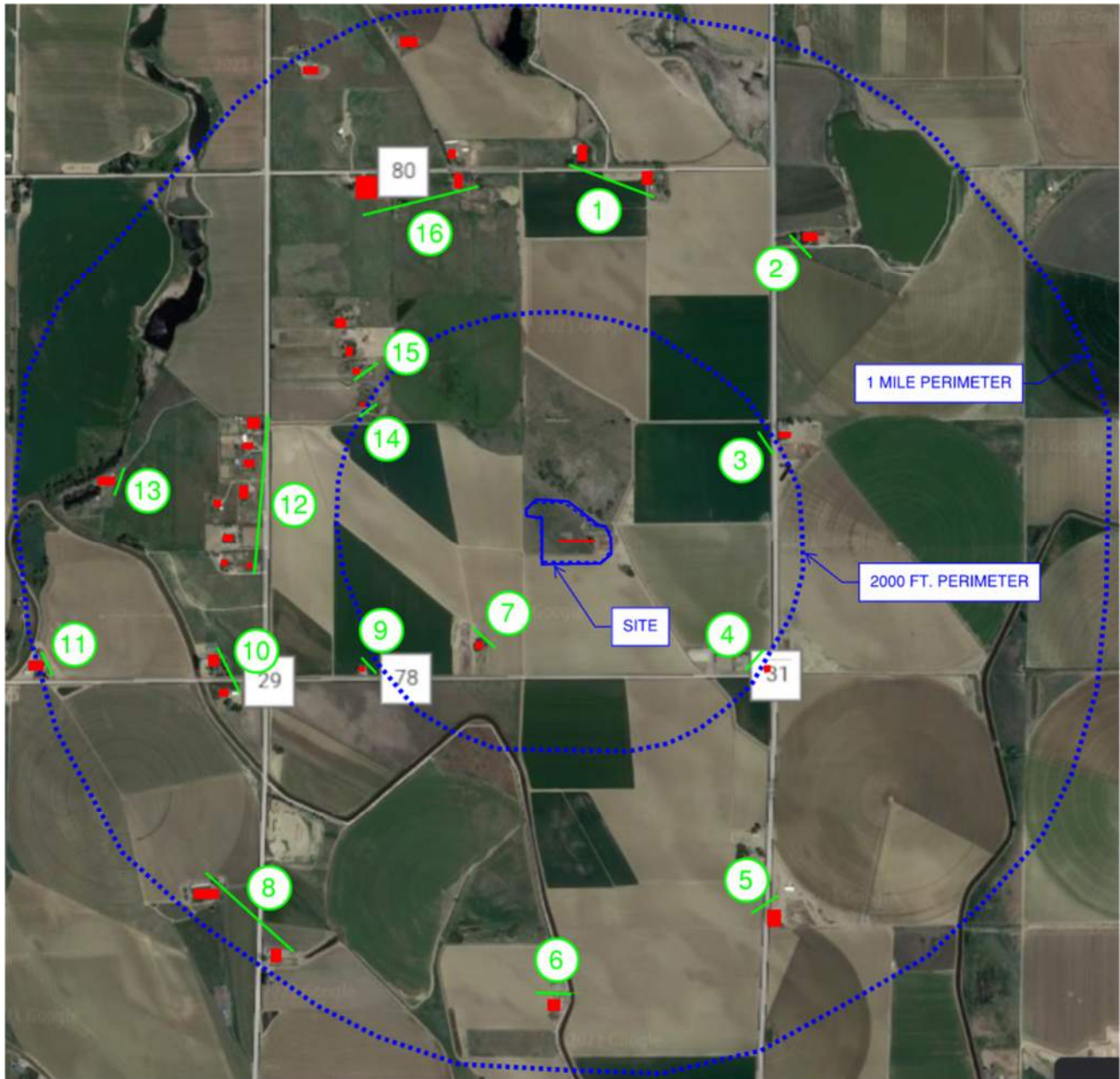

LEGEND

- - BUILDING UNIT
- - ANALYZED CUMULATIVE LIGHT IMPACT LOCATION AS MEASURE 5.5FT ABOVE GRADE

Figure 4.1 – Building Units Within a 1-Mile Radius of Garnet 21-K Site

Calculated Lighting Impact Results				
Building Unit No.	Pre-Production Drilling	Pre-Production Completions	Production	Regulatory Limit
1	< 0.1 lux	< 0.1 lux	< 0.1 lux	4 lux
2	< 0.1 lux	< 0.1 lux	< 0.1 lux	4 lux
3	< 0.1 lux	< 0.1 lux	< 0.1 lux	4 lux
4	< 0.1 lux	< 0.1 lux	< 0.1 lux	4 lux
5	< 0.1 lux	< 0.1 lux	< 0.1 lux	4 lux
6	< 0.1 lux	< 0.1 lux	< 0.1 lux	4 lux
7	0.18 lux	< 0.1 lux	< 0.1 lux	4 lux
8	< 0.1 lux	< 0.1 lux	< 0.1 lux	4 lux
9	< 0.1 lux	< 0.1 lux	< 0.1 lux	4 lux
10	< 0.1 lux	< 0.1 lux	< 0.1 lux	4 lux
11	< 0.1 lux	< 0.1 lux	< 0.1 lux	4 lux
12	< 0.1 lux	< 0.1 lux	< 0.1 lux	4 lux
13	< 0.1 lux	< 0.1 lux	< 0.1 lux	4 lux
14	< 0.1 lux	< 0.1 lux	< 0.1 lux	4 lux
15	< 0.1 lux	< 0.1 lux	< 0.1 lux	4 lux
16	< 0.1 lux	< 0.1 lux	< 0.1 lux	4 lux

Table 4.1 – Building Units Within a 1-Mile Radius of Garnet 21-K Site

Table 4.1 demonstrates compliance with COGCC Rule 424.f.

4.2 HARDSCAPE VS LUMEN LEVEL RESULTS

Applicable Code Reference: Weld County Ordinance ORD2020-12 TABLE 405 B.1 (B)

Lumens per hardscape calculations were performed based on the number of exterior fixtures light output (lumens) and the working pad surface (hardscape). The calculated lumen values were then compared to the regulatory allowed site lumens per square foot to demonstrate compliance.

4.2.1 Pre-Production Drilling Hardscape per Lumens Compliance

Pre-Production Drilling Lighting Compliance		
	Calculated Value	Notes
Site Hardscape Area:	400,752 ft ²	
Site Hardscape Acres:	9.2 Acres	
Site Total Lumens:	1,645,809 lm	See Section 5.2
Site Allowance Initial Lumens Total:	4,809,024 lm	
Calculated Site (Lumens / ft ²):	4.1 lm/(ft ²)	Construction Site is Verified
Regulatory Allowed Limit:	12 lm/(ft ²)	Per Weld County Ordinance ORD2020-12 Table 405 B.1

Table 4.2.1 – Pre-Production Drilling Operation Compliance Calculation

Based on the calculation shown in Table 4.2.1, the estimated site lighting during the Pre-Production Drilling operation phase is less than the regulatory maximum value and in compliance with Weld County Ordinance ORD2020-12.

4.2.2 Pre-Production Completions Hardscape per Lumens Compliance

Pre-Production Completions Lighting Compliance		
	Calculated Value	Notes
Site Hardscape Area:	400,752 ft ²	
Site Hardscape Acres:	9.2 Acres	
Site Total Lumens:	815,200 lm	See Section 5.5
Site Allowance Initial Lumens Total:	4,809,024 lm	
Calculated Site (Lumens / ft ²):	2.0 lm/(ft ²)	Construction Site is Verified
Regulatory Allowed Limit:	12 lm/(ft ²)	Per Weld County Ordinance ORD2020-12 Table 405 B.1

Table 4.2.2 – Pre-Production Completions Operation Compliance Calculation

Based on the calculation shown in Table 4.2.2, the estimated site lighting during the Pre-Production Completions operation phase is less than the regulatory maximum value and in compliance with Weld County Ordinance ORD2020-12.

4.2.3 Production Hardscape per Lumens Compliance

Production Lighting Compliance		
	Calculated Value	Notes
Site Hardscape Area:	239,580 ft ²	
Site Hardscape Acres:	5.5 Acres	
Site Total Lumens:	127,360 lm	See Section 5.6
Planning Zone for Weld County:	LZ-2	“Near Urban Planning Zone” based on Weld County Appendix 21-B
Calculated Site (Lumens / ft ²):	0.5 lm/(ft ²)	Production Site is Verified
Regulatory Allowed Limit:	2.5 lm/(ft ²)	Weld County Sec. 21-5-405 Table 405. C.1 & COGCC Rule 424.d.(2)

Table 4.2.3 – Production Operation Compliance Calculation

Based on the calculation shown in Table 4.2.3, the estimated site lighting during the Production operation phase is less than the regulatory maximum value and in compliance with Weld County Ordinance ORD2020-12 and COGCC Rule 424.d.(2) for Commercial/Agricultural.

5.0 SITE LIGHTING POSITIONS AND ORIENTATION

5.1 SITE LIGHTING NOTES

Applicable Code Reference: COGCC Rule 424(a)(2)(A)(ii)

Pertaining to Pre-Production activities: *"The proposed anticipated location, mounting, height, and orientation of all outdoor lighting fixtures on the site during pre-production activities"*

The following figures and tables in this section show the lighting location, mounting, height, and orientations for the Pre-Production Drilling, Completions, and Production Operations, in accordance with COGCC Rule 424(a)(2)(A)(ii). The following notes apply:

- 1) Stated tilt at zero (0) degrees represents a luminaire facing directly downward.

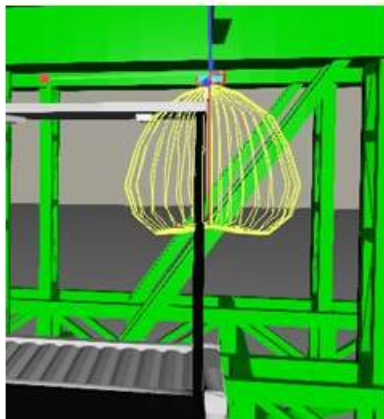

Figure 5.0 Example 0 degrees

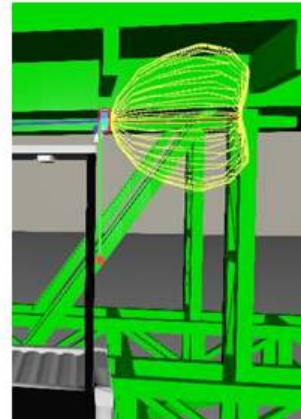
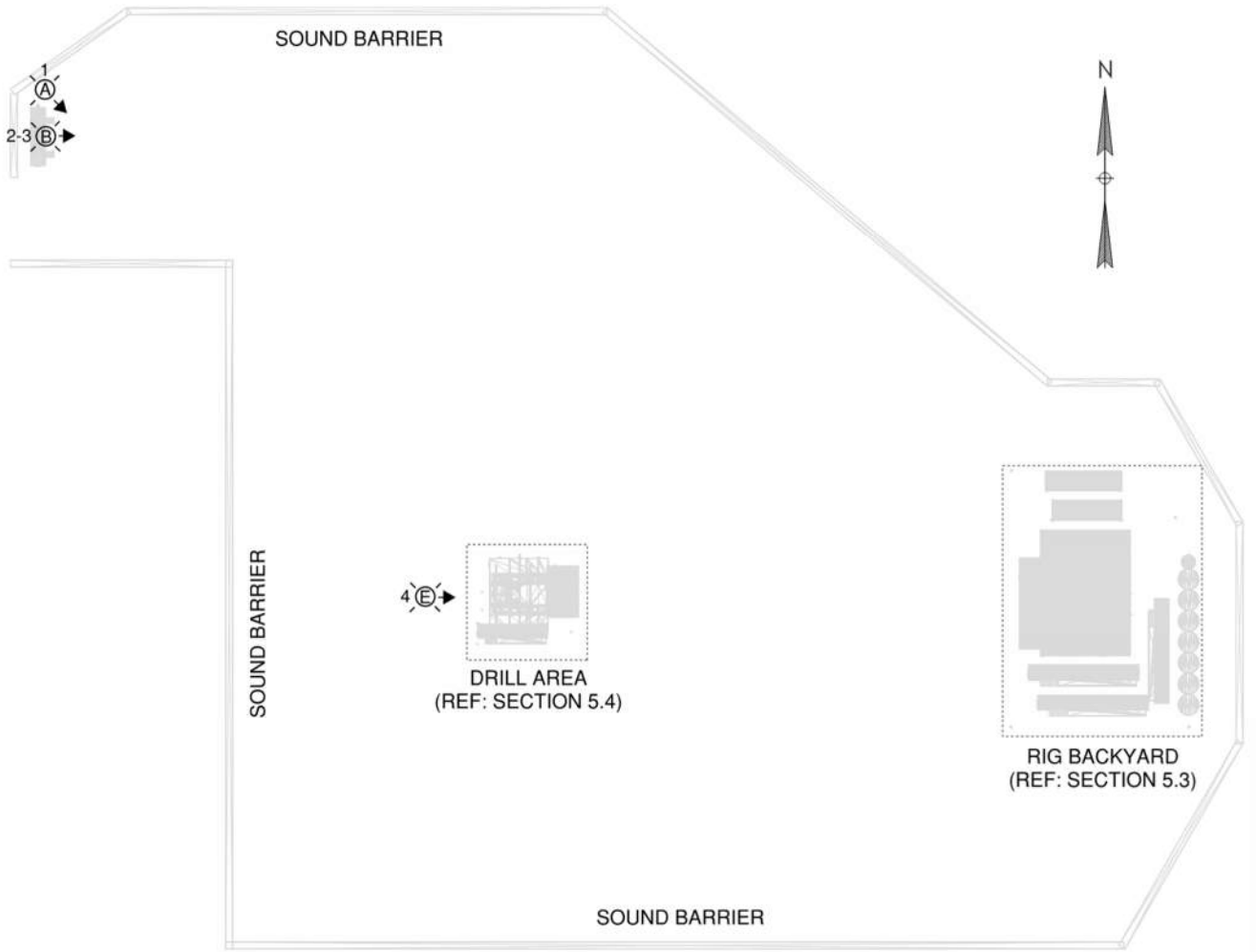

Figure 5.1 Example 90 degrees

- 2) Intermittent Sources of Lights such as glow from on-site combustor and alarm lights are not included in this analysis.
- 3) Temporary lighting where necessary for safety reasons per COGCC 424.a.2.A.iii have not been modeled or accounted for in this analysis.
- 4) The quantity of lights and calculated values shown represents an estimated upper limit to the actual values that will be present on-site.
- 5) Refer to Attachment A for further lighting fixture information.

5.2 PRE-PRODUCTION - DRILLING SITE LAYOUT AND LUMINAIRE SCHEDULE



LUMINAIRE LAYOUT
 BAYSWATER GARNET 21-K – OVERALL SITE LAYOUT
 PRE-PRODUCTION – CONSTRUCTION
 DRILLING OPERATIONS

Luminaire Schedule					
Luminaire Type	Manufacturer	Model Number	Description	Power (Watts)	Luminous Flux (Φ)
A	HPWINNER	M4	LED - TEMP. LIGHTING SYSTEM	1,696 W	88,000 lm
B	STANPRO	WPS	LED – WALL PACK	40 W	5,800 lm
E	EATON COOPER CROUSE-HINDS	DFLMYM400	HID – HAZ. AREA CLEAR GLASS	400 W	40,000 lm

Luminaire Position and Tilt				
Luminaire No.	Mounting Height (ft)	Tilt (Degrees)	Luminaire Type	Luminous Flux (Φ)
1	16'	75°	A	88000 lm
2	11'	0°	B	5800 lm
3	11'	0°	B	5800 lm
4	15'	75°	E	40000 lm
Total Lumens Calculation				
Subtotal Area Calculation:				139,600 lm
Total Detail "A" Lumens:				780,528 lm
Total Detail "B" Lumens:				725,681 lm
Total Area Lumens:				1,645,809 lm

5.3 PRE-PRODUCTION - DRILLING - DETAIL A - SITE LAYOUT AND LUMINAIRE SCHEDULE

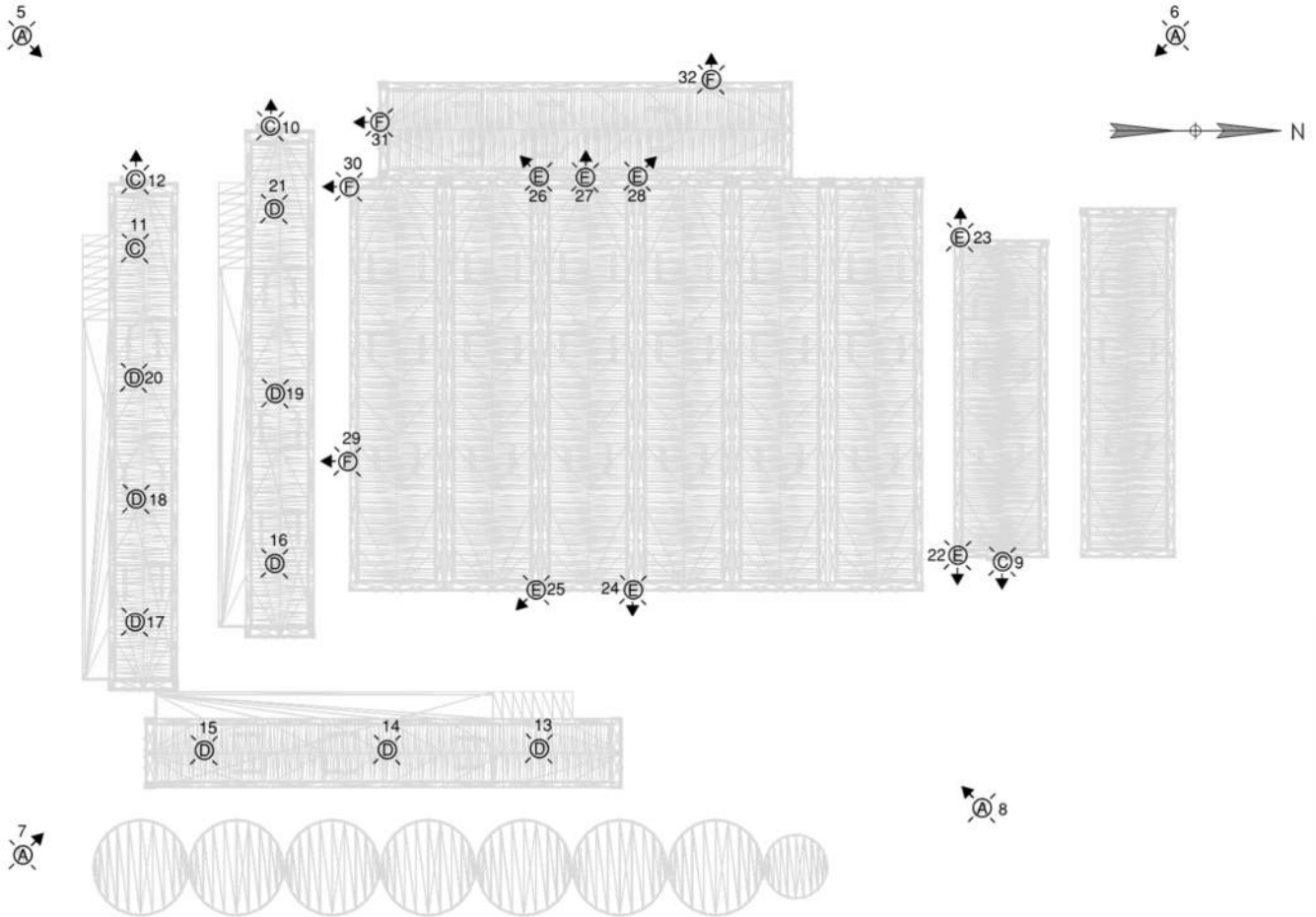

LUMINAIRE LAYOUT
 BAYSWATER GARNET 21-K – RIG BACKYARD – DETAIL A
 PRE-PRODUCTION – CONSTRUCTION
 DRILLING OPERATIONS

Luminaire Schedule					
Luminaire Type	Manufacturer	Model Number	Description	Power (Watts)	Luminous Flux (Φ)
A	HPWINNER	M4	LED - TEMP. LIGHTING SYSTEM	1,696 W	88,000 lm
C	EATON – COOPER CROUSE HINDS	DLL4/UNV1S903	LED – 4FT LINEAR POLYCARBONATE	63 W	7,619 lm
D	DIALIGHT	HEU4MC2ANNWNGN	LED – HIGH BAY	80 W	11,500 lm
E	EATON COOPER CROUSE-HINDS	DFLMYM400	HID – HAZ. AREA CLEAR GLASS	400 W	40,000 lm
F	EATON – COOPER CROUSE HINDS	DLL2/UNV1S903	LED – 2FT LINEAR POLYCARBONATE	32 W	3,938 lm

Luminaire Position and Tilt				
Luminaire No.	Mounting Height (ft)	Tilt (Degrees)	Luminaire Type	Luminous Flux (Φ)
5	16'	75°	A	88000 lm
6	16'	75°	A	88000 lm
7	16'	75°	A	88000 lm
8	16'	75°	A	88000 lm
9	9'	75°	C	7619 lm
10	9'	75°	C	7619 lm
11	9'	75°	C	7619 lm
12	15'	0°	C	7619 lm
13	15'	0°	D	11500 lm
14	15'	0°	D	11500 lm
15	15'	0°	D	11500 lm
16	15'	0°	D	11500 lm
17	15'	0°	D	11500 lm
18	15'	0°	D	11500 lm
19	15'	0°	D	11500 lm
20	15'	0°	D	11500 lm
21	15'	0°	D	11500 lm
22	15'	75°	E	40000 lm
23	15'	75°	E	40000 lm
24	15'	75°	E	40000 lm
25	15'	75°	E	40000 lm
26	15'	75°	E	40000 lm
27	15'	75°	E	40000 lm
28	15'	75°	E	40000 lm
29	9'	75°	F	3638 lm
30	9'	75°	F	3638 lm
31	9'	75°	F	3638 lm
32	9'	75°	F	3638 lm
Total Lumens Calculation				
Total Area Lumens:				780,528 lm

5.4 PRE-PRODUCTION - DRILLING - DETAIL B - SITE LAYOUT AND LUMINAIRE SCHEDULE

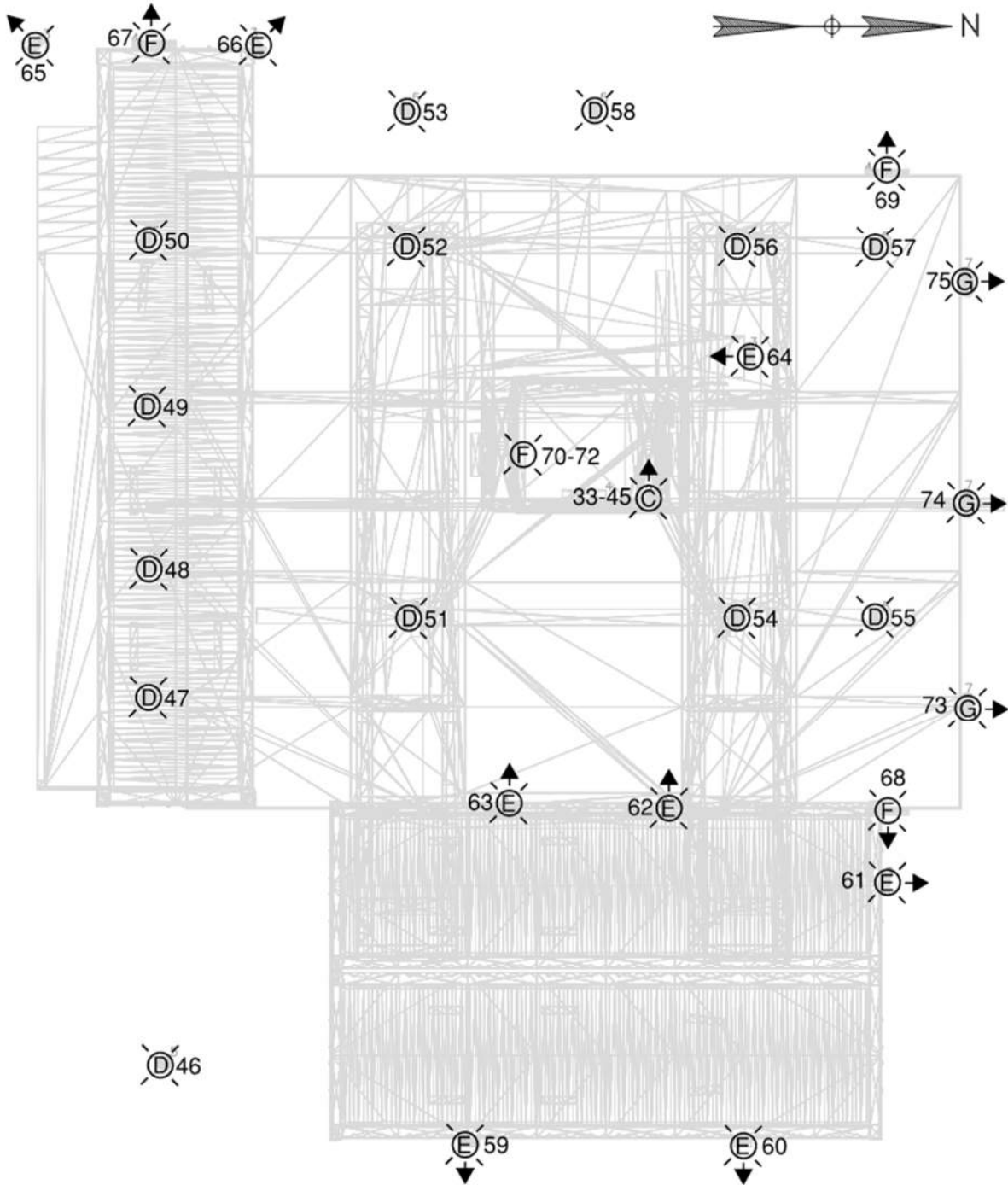

LUMINAIRE LAYOUT
BAYSWATER GARNET 21-K – DRILL AREA – DETAIL B
PRE-PRODUCTION – CONSTRUCTION
DRILLING OPERATIONS

Luminaire Schedule					
Luminaire Type	Manufacturer	Model Number	Description	Power (Watts)	Luminous Flux (Φ)
C	EATON – COOPER CROUSE HINDS	DLL4/UNV1S903	LED – 4FT LINEAR POLYCARBONATE	63 W	7,619 lm
D	DIALIGHT	HEU4MC2ANNWNGN	LED – HIGH BAY	80 W	11,500 lm
E	EATON COOPER CROUSE-HINDS	DFLMYM400	HID – HAZ. AREA CLEAR GLASS	400 W	40,000 lm
F	EATON – COOPER CROUSE HINDS	DLL2/UNV1S903	LED – 2FT LINEAR POLYCARBONATE	32 W	3,938 lm
G	RAB	FXLED300SF	LED – HIGH OUTPUT FLOODLIGHT	326 W	45,102

Luminaire Position and Tilt				
Luminaire No.	Mounting Height (ft)	Tilt (Degrees)	Luminaire Type	Luminous Flux (Φ)
33	45'	90°	C	7619 lm
34	53'	90°	C	7619 lm
35	60'	90°	C	7619 lm
36	68'	90°	C	7619 lm
37	76'	90°	C	7619 lm
38	83'	90°	C	7619 lm
39	91'	90°	C	7619 lm
40	99'	90°	C	7619 lm
41	106'	90°	C	7619 lm
42	114'	90°	C	7619 lm
43	122'	90°	C	7619 lm
44	129'	90°	C	7619 lm
45	137'	90°	C	7619 lm
46	24'	0°	D	11500 lm
47	24'	0°	D	11500 lm
48	24'	0°	D	11500 lm
49	24'	0°	D	11500 lm
50	24'	0°	D	11500 lm
51	24'	0°	D	11500 lm
52	24'	0°	D	11500 lm
53	24'	0°	D	11500 lm
54	24'	0°	D	11500 lm
55	20'	0°	D	11500 lm
56	20'	0°	D	11500 lm
57	20'	0°	D	11500 lm
58	20'	0°	D	11500 lm

Luminaire Position and Tilt				
Luminaire No.	Mounting Height (ft)	Tilt (Degrees)	Luminaire Type	Luminous Flux (Φ)
59	21'	75°	E	40000 lm
60	21'	75°	E	40000 lm
61	21'	75°	E	40000 lm
62	21'	75°	E	40000 lm
63	21'	75°	E	40000 lm
64	21'	75°	E	40000 lm
65	21'	75°	E	40000 lm
66	44'	75°	E	40000 lm
67	38'	75°	F	3638 lm
68	38'	75°	F	3638 lm
69	9'	75°	F	3638 lm
70	45'	0°	F	3638 lm
71	45'	0°	F	3638 lm
72	45'	0°	F	3638 lm
73	38'	75°	G	45102 lm
74	38'	75°	G	45102 lm
75	38'	75°	G	45102 lm
Total Lumens Calculation				
Total Area Lumens:				725,681 lm

5.5 PRE-PRODUCTION - COMPLETIONS - SITE LAYOUT AND LUMINAIRE SCHEDULE

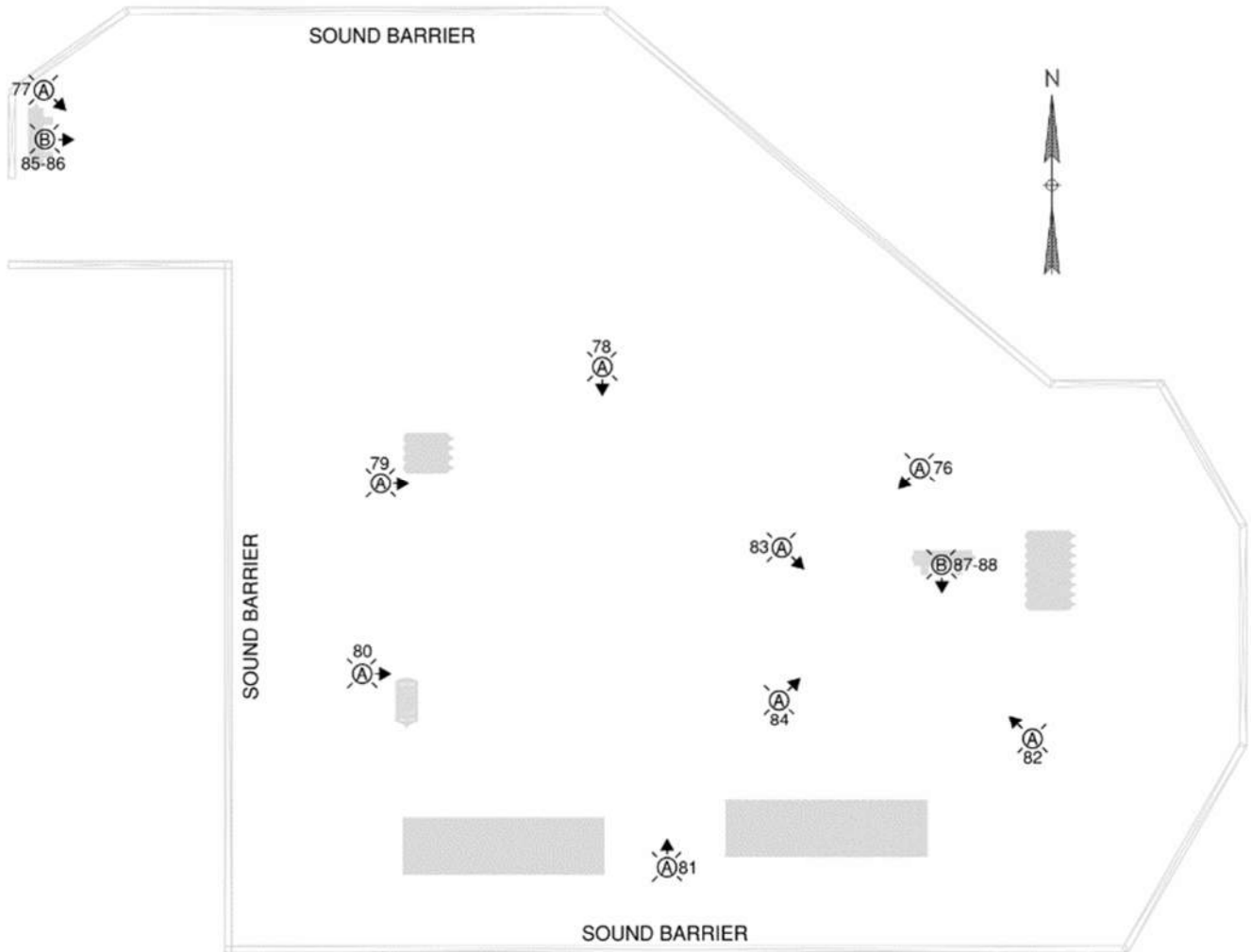

LUMINAIRE LAYOUT
 BAYSWATER GARNET 21-K – COMPLETIONS
 PRE-PRODUCTION – CONSTRUCTION

Luminaire Schedule					
Luminaire Type	Manufacturer	Model Number	Description	Power (Watts)	Luminous Flux (Φ)
A	HPWINNER	M4	LED - TEMP. LIGHTING SYSTEM	1,696 W	88,000 lm
B	STANPRO	WPS	LED – WALL PACK	40 W	5,800 lm

Luminaire Position and Tilt				
Luminaire No.	Mounting Height (ft)	Tilt (Degrees)	Luminaire Type	Luminous Flux (Φ)
76	16'	75°	A	88000 lm
77	16'	75°	A	88000 lm
78	16'	75°	A	88000 lm
79	16'	75°	A	88000 lm
80	16'	75°	A	88000 lm
81	16'	75°	A	88000 lm
82	16'	75°	A	88000 lm
83	16'	75°	A	88000 lm
84	16'	75°	A	88000 lm
85	11'	75°	B	5800 lm
86	11'	75°	B	5800 lm
87	11'	75°	B	5800 lm
88	11'	75°	B	5800 lm
Total Lumens Calculation				
Total Area Lumens:				815,200 lm

5.6 PRODUCTION - SITE LAYOUT, LUMINAIRE SCHEDULE, AND PHOTOMETRIC

The luminaire layout follows a standardized design approach that is adjusted for site equipment layout.

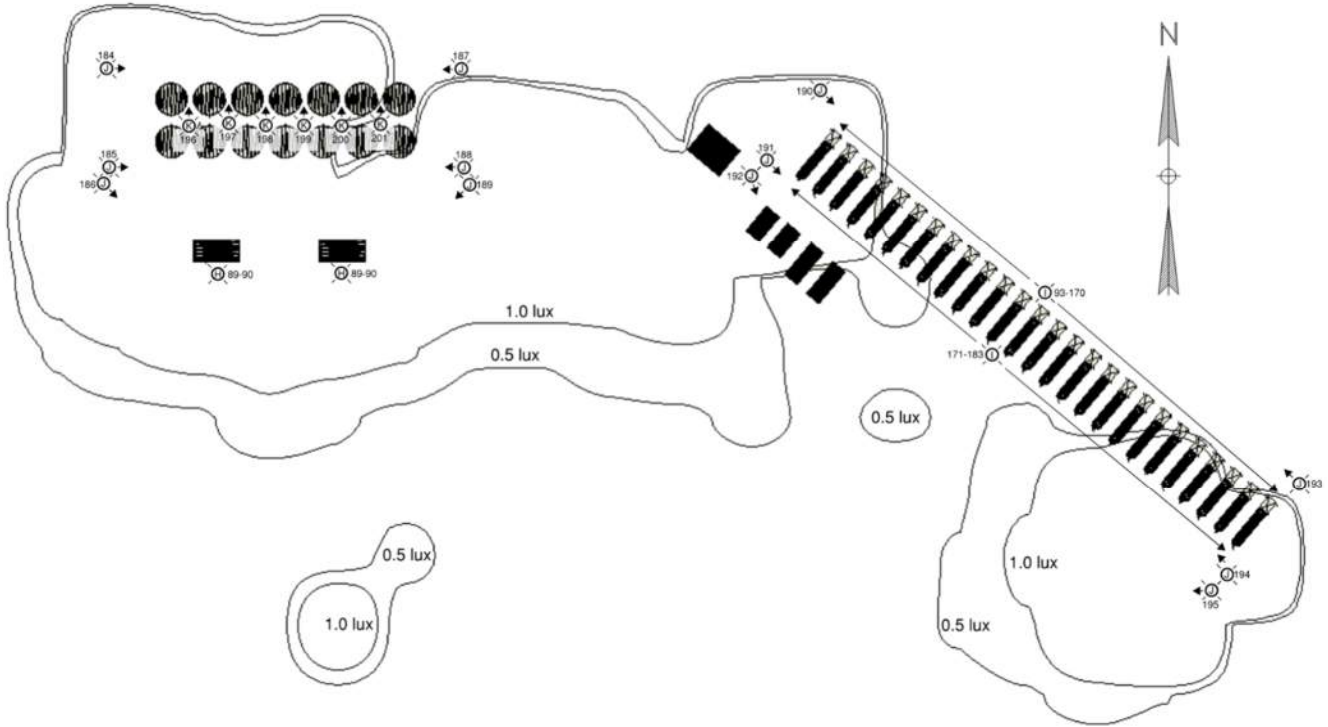

LUMINAIRE LAYOUT & PHOTOMETRIC
 BAYSWATER GARNET 21-K – PRODUCTION AREA
 PRODUCTION OPERATIONS

Luminaire Schedule					
Luminaire Type	Manufacturer	Model Number	Description	Power (Watts)	Luminous Flux (Φ)
H	PHOENIX	CL	LED CUBE LIGHT	13 W	1006 lm
I	RAYCHEM	E-100	LED – HEAT TRACE END SEAL KIT	2 W	60 lm
J	EATON – COOPER CROUSE HINDS	FMVA9LWYUNV176-S891	LED – FLOODLIGHT	79.2 W	7577 lm
K	EATON – COOPER CROUSE HINDS	VMVL-5-W-P-R1-UNV1-S891	LED – STANCHION MOUNT	43 W	4492 lm

Luminaire Position and Tilt				
Luminaire No.	Mounting Height (ft)	Tilt (Degrees)	Luminaire Type	Luminous Flux (Φ)
89	9'	0°	H	1006 lm
90	9'	0°	H	1006 lm
91	9'	0°	H	1006 lm
92	9'	0°	H	1006 lm
93	5'	180°	I	60 lm
94	5'	180°	I	60 lm
95	5'	180°	I	60 lm
96	5'	180°	I	60 lm
97	5'	180°	I	60 lm
98	5'	180°	I	60 lm
99	5'	180°	I	60 lm
100	5'	180°	I	60 lm
101	5'	180°	I	60 lm
102	5'	180°	I	60 lm
103	5'	180°	I	60 lm
104	5'	180°	I	60 lm
105	5'	180°	I	60 lm
106	5'	180°	I	60 lm
107	5'	180°	I	60 lm
108	5'	180°	I	60 lm
109	5'	180°	I	60 lm
110	5'	180°	I	60 lm
111	5'	180°	I	60 lm
112	5'	180°	I	60 lm
113	5'	180°	I	60 lm
114	5'	180°	I	60 lm
115	5'	180°	I	60 lm
116	5'	180°	I	60 lm
117	5'	180°	I	60 lm
118	5'	180°	I	60 lm
119	5'	180°	I	60 lm
120	5'	180°	I	60 lm
121	5'	180°	I	60 lm
122	5'	180°	I	60 lm
123	5'	180°	I	60 lm
124	5'	180°	I	60 lm
125	5'	180°	I	60 lm
126	5'	180°	I	60 lm
127	5'	180°	I	60 lm
128	5'	180°	I	60 lm

Luminaire Position and Tilt				
Luminaire No.	Mounting Height (ft)	Tilt (Degrees)	Luminaire Type	Luminous Flux (Φ)
129	5'	180°	I	60 lm
130	5'	180°	I	60 lm
131	5'	180°	I	60 lm
132	5'	180°	I	60 lm
133	5'	180°	I	60 lm
134	5'	180°	I	60 lm
135	5'	180°	I	60 lm
136	5'	180°	I	60 lm
137	5'	180°	I	60 lm
138	5'	180°	I	60 lm
139	5'	180°	I	60 lm
140	5'	180°	I	60 lm
141	5'	180°	I	60 lm
142	5'	180°	I	60 lm
143	5'	180°	I	60 lm
144	5'	180°	I	60 lm
145	5'	180°	I	60 lm
146	5'	180°	I	60 lm
147	5'	180°	I	60 lm
148	5'	180°	I	60 lm
149	5'	180°	I	60 lm
150	5'	180°	I	60 lm
151	5'	180°	I	60 lm
152	5'	180°	I	60 lm
153	5'	180°	I	60 lm
154	5'	180°	I	60 lm
155	5'	180°	I	60 lm
156	5'	180°	I	60 lm
157	5'	180°	I	60 lm
158	5'	180°	I	60 lm
159	5'	180°	I	60 lm
160	5'	180°	I	60 lm
161	5'	180°	I	60 lm
162	5'	180°	I	60 lm
163	5'	180°	I	60 lm
164	5'	180°	I	60 lm
165	5'	180°	I	60 lm
166	5'	180°	I	60 lm
167	5'	180°	I	60 lm
168	5'	180°	I	60 lm

Luminaire Position and Tilt				
Luminaire No.	Mounting Height (ft)	Tilt (Degrees)	Luminaire Type	Luminous Flux (Φ)
169	5'	180°	I	60 lm
170	5'	180°	I	60 lm
171	5'	180°	I	60 lm
172	5'	180°	I	60 lm
173	5'	180°	I	60 lm
174	5'	180°	I	60 lm
175	5'	180°	I	60 lm
176	5'	180°	I	60 lm
177	5'	180°	I	60 lm
178	5'	180°	I	60 lm
179	5'	180°	I	60 lm
180	5'	180°	I	60 lm
181	5'	180°	I	60 lm
182	5'	180°	I	60 lm
183	5'	180°	I	60 lm
184	25'	45°	J	7577 lm
185	25'	45°	J	7577 lm
186	25'	45°	J	7577 lm
187	25'	45°	J	7577 lm
188	25'	45°	J	7577 lm
189	25'	45°	J	7577 lm
190	25'	45°	J	7577 lm
191	25'	45°	J	7577 lm
192	25'	45°	J	7577 lm
193	25'	45°	J	7577 lm
194	25'	45°	J	7577 lm
195	25'	45°	J	7577 lm
196	7'	25°	K	4492 lm
197	7'	25°	K	4492 lm
198	7'	25°	K	4492 lm
199	7'	25°	K	4492 lm
200	7'	25°	K	4492 lm
201	7'	25°	K	4492 lm
Total Lumens Calculation				
Total Area Lumens:				127,360 lm

6.0 SITE MITIGATION NOTES AND TECHNIQUES

The following mitigation notes and techniques apply:

- 1) To the extent possible, LED fixtures are used to reduce skyglow. This is based on the calculated results of the relative impact versus traditional lighting methods using DOE Skyglow comparison tool PNNL-SA-138348. (Pre-Production and Production Phase)
- 2) All lights have been positioned to point in a downward direction where vertical lighting is not required. Where it is required, lights are angled in a vertical direction to provide task lighting for safety and operations involving personnel. (Pre-Production and Production Phase)
- 3) Luminaire Type "C" used on the Derrick mast are facing horizontally to provide adequate lighting for safe operations. (Pre-Production)
- 4) Luminaire Lights Type "H", "J" and "K" are used exclusively for lighting when required for operations at night for safety reasons. Otherwise, these lights are to remain off and shutoff after use. The values for these lights are included in the analysis as an upper limit to the actual values that will be present on site. (Production Phase).
- 5) Luminaire Lights Type "I" are an estimation of lighting associate with heat trace and will remain on to indicate status of heat trace operation. (Production Phase)
- 6) To the extent possible, design considerations have been made regarding the type of light fixtures used, quantity, and positioning to reduce various forms of lighting pollution. Examples include:
 - Lighting is angled away from surrounding off site buildings.
 - Lighting for production area will be off when not required.
 - Lights are switched off when not required.
 - Lights are directed to task areas only.
 - Low power LED lights are used for the drill rig.
 - Sound barriers are positioned to reduce lighting trespass to surrounding off-site buildings.
 - The calculated cumulative light impacts, as indicated in Section 4.1, on surrounding buildings within a one-mile radius area are below 4 lux when measured 5.5 feet above grade.
- 7) Lighting Cut Sheet Notes for Attachment A
 1. Type A Fixtures (Pre-Production Phase) are representative of current fixtures used temporary light towers for task and operations in drilling and completions.
 2. Type B fixtures (Pre-Production Phase) are representative of current fixtures used trailer and area lighting for drilling and completions.
 3. Type C Fixtures (Pre-Production Phase) are representative of current fixtures used for drilling operations.
 4. Type D Fixtures (Pre-Production Phase) are representative of current fixtures used for drilling operations.

5. Type E Fixtures (Pre-Production Phase) are representative of current fixtures used for drilling operations.
6. Type F Fixtures (Pre-Production Phase) are representative of current fixtures used for drilling operations.
7. Type G Fixtures (Pre-Production Phase) are representative of current fixtures used for drilling operations.
8. Type H Fixtures (Production Phase) are representative of current fixtures used for production operations.
9. Type I Fixtures (Production Phase) are representative of current fixtures used for production operations.
10. Type J Fixtures (Production Phase) are representative of current fixtures used for production operations.
11. Type K Fixtures (Production Phase) are representative of current fixtures used for production operations.

7.0 ATTACHMENTS

Attachment A – Lighting Cutsheets

END OF REPORT

ATTACHMENT A
FIXTURE CUT SHEETS TYPES A,B,C,D,E,F,G,H,I,J,K
LIGHTING MITIGATION PLAN
FOR



GARNET 21-K

Project Number: 21282

FIXTURE CUT SHEET TYPE A

Notes for Type A

1. Type A fixtures are portable construction light towers with vertical masts. These units vary significantly depending on supplier, rental agency inventory, and current market available fixtures. This model is representative based on site inspections and provided information from typical vendors used. These represent a typical LED unit with a total lumen output indicated. The model for these portable light towers consists of a LED light source with 4 fixtures. Each fixture is comprised of 4 LED modules mounted in a rectangular arrangement for each light mast. The attached cut sheet for HP Winner represents 1 LED module. 16 total modules were used for each light mast.

2. The typical light pole center of fixtures is raised approximately 16 feet from grade and pointed downward toward the work area.

3. The fixture mounting for portable light towers are articulated mountings which allows for both vertical and horizontal plane adjustments. For the analysis light masts fixtures were modeled at horizontal angle indicated.

TYPE A Model Example Used



LED Module M8B Series

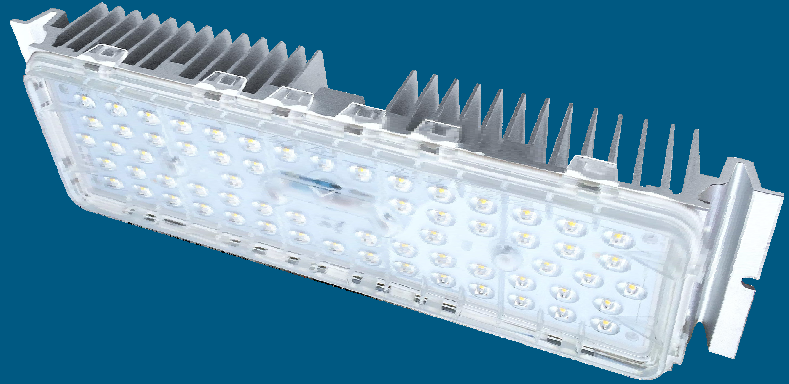

Specification

Working Environment: -40°C~+50°C

Storage Temperature: -40°C~+50°C

Relative humidity: 10%~90%RH

Typical value of pad temperature^[1]: 70°C

IP Rating of LED Light Engine: IP68

Impact Protection Level: IK09

Color Temperature (CCT)^[2]: 3000K, 4000K, 5000K, 5700K

Main Material: Aluminum 6063

Module N.W.: 0.67±0.04 kg

Note :

[1] Typical values of pad temperature is obtained based on 60W with a ambient temperature of 25°C.

[2] Efficacy of 3000K is 5% lower than other CCTs.

Features

- Lumileds Luxeon 3030;
- Super long lifetime(Lumen maintenance);
- Multiple lighting distributions available;
- Wide applicability for complex situations;
- High versatility apply for all sorts of lamps retrofit.

Application

- Street lighting retrofit and application;
- Factory lighting retrofit and application;
- Tunnel lighting retrofit and application;
- Sports lighting retrofit and application.

Ordering Information

For example: M8B-VCA-63 -1321-7040-LU

Module Model	Interface	Dimension of LEDS	Wire Material	LED Qty	Lens Model		Ra & CCT	LED Brand
M8B	V: V-shape Groove	C: 3030	A: CCC+VDE C: PSE H: UL X: Others	49 49PCS	1324 Type II Short	1325 25 DEG	7030: Ra≥70, 3000K 8040: Ra≥80, 4000K ...	LU: Lumileds
				63 63PCS	2322 Type II Short (V)	2360 60 DEG		SN: Sanan
					5321 Type II Short	5340 40 DEG		XX: Others
					2321 Type II Short	5390 90 DEG		
					1321 Type III Medium	1310 Lambert Type		
					1390 Tunnel Lighting			

Performance

Model	Power (W)	Driving current (mA)	Input voltage (Vdc)	Efficacy (lm/W)	Lumens (lm)
M8B-VCA-63	40	700	48~61	140	5600
M8B-VCA-49	50	1050	38~48	127	6350
M8B-VCA-63	50	860	48~61	135	6750
M8B-VCA-63	60	1050	48~61	127	7620

Note : Values shown are subject to ±5%~±8% tolerance; Cable default A type;

Efficacy above is based on calculated @92% power efficiency ; Light efficacy of 3000K is 5% lower than other CCTs.

Dimensions

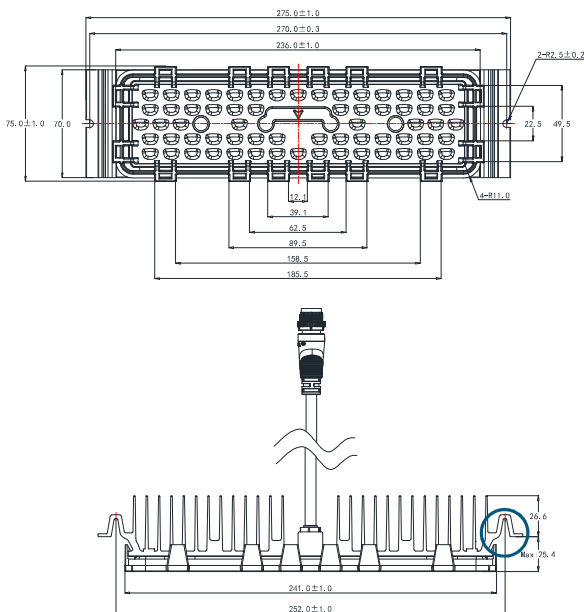

L (mm)	W (mm)	H (mm)
275	75	Max52

The height of the module is the maximum value.

Tolerance: ±0.5mm

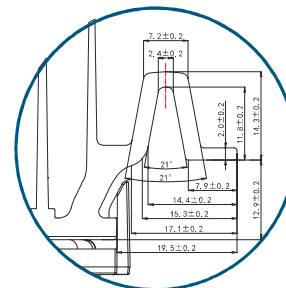

Available Lens Model

1321	1324	1390
1232	2322	5321

Dimensions

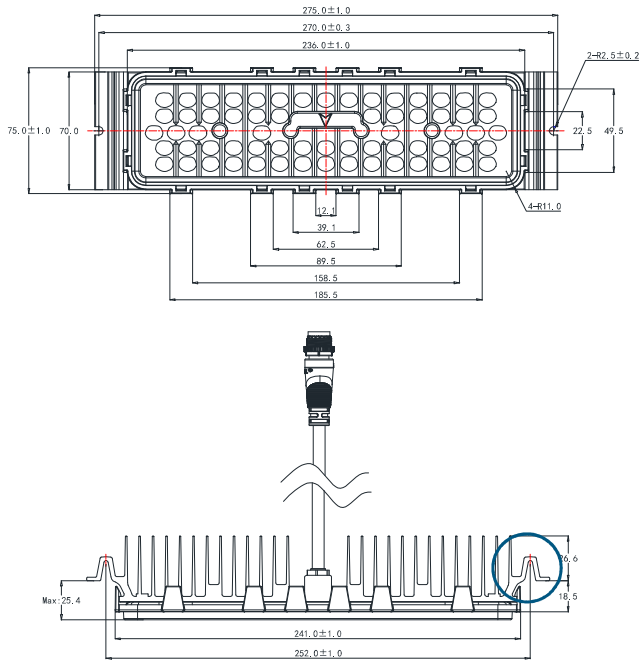

L (mm)	W (mm)	H (mm)
--------	--------	--------

275 75 Max52

The height of the module is the maximum value.

Tolerance: ±0.5mm

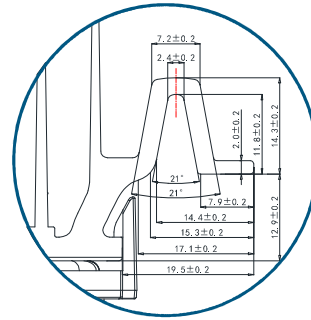

Available Lens Model

1310	1325	5340	2360
5390			

Package Information

L (mm)	W (mm)	H (mm)	Module pcs/carton (PCS)	Package weight (kg)
650	375	190	20	14.9

Values shown are subject to ±5% tolerance.

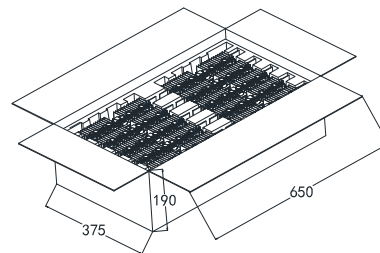
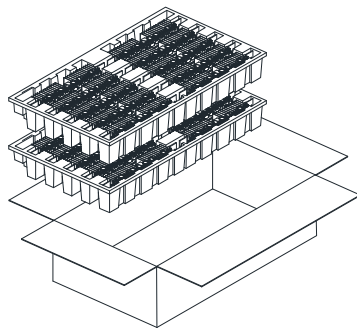

Lighting distributions

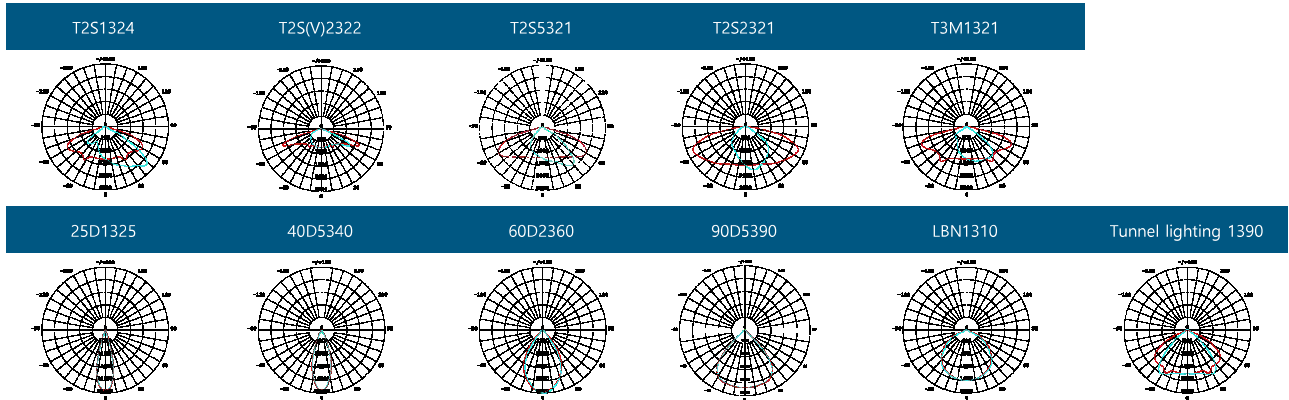

Version History

Change Date	Version	Description of Change		
		Item	From	To
20190905	Ver2.0	Data sheets release (new version) Update of luminous efficacy Optimized G.W of Module package	16.2kgs	14.9kgs

LUMINAIRE CLASSIFICATION SYSTEM (LCS) GRAPH

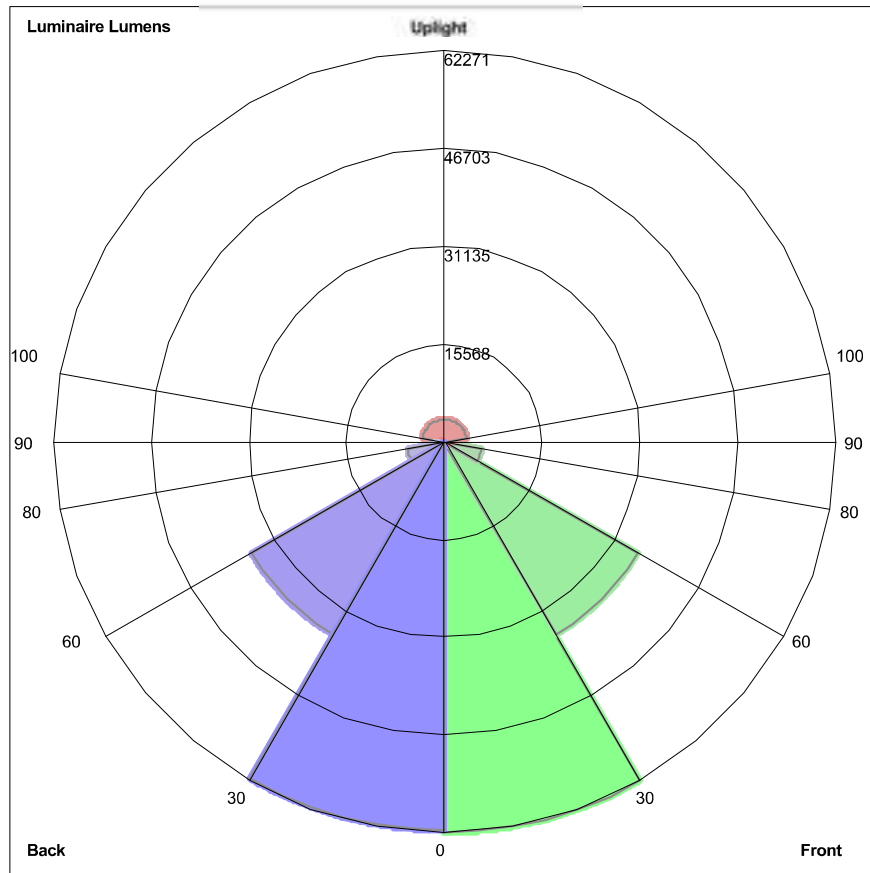

Luminaire Lumens:
Front: Low=62270.6, Medium=35421.7, High=5946.3, Very High= 1328.0
Back: Low= 61920.0, Medium=35466.8, High=5958.8, Very High=1320.7
Uplight: Low=493.0, High=3564.5

BUG Rating : B5-U5-G5

FIXTURE CUT SHEET

TYPE B

Series Spec Sheet

WPS GEN 4

CLASSIC WALL PACK

Selectable color temperature (3 000 K / 4 000 K / 5 000 K)¹

Power selectable¹

Integrated photocell¹

Multi-Voltage (120-347 V)¹

This wall pack series is a classic and familiar design integrated with modern LED technology to promote better energy efficiency and long life. Certain configurations come with integrated photocell, selectable power and/or selectable color temperature. It is best suited for entrances, underpasses or anywhere controlled security lighting is required, the series luminaire is a great addition to any commercial or industrial outdoor wall mount application. The tough die cast aluminum housing is moisture and dustproof. ¹

FEATURES AND SPECIFICATIONS

• Construction

Housing

- This luminaire is made of aluminum die cast and comes standard in a bronze powder coat finish.
- The housing has four conduit entries of 1/2" on each sides and some of the configurations comes with a button type photocell that can be turned off by using the internal switch if needed.¹

Lens

Prismatic tempered glass lens is standard in this product series.

• Electrical

- The drivers allows an input voltage from 120-277 V or 120-347 V AC 50/60 Hz and are 0-10 V dimmable. They are coming with an onboard surge protection:
 - NS29: 2.5kV standard
 - NS40, NS60, NS80, PS40, PS100: 2kV standard
 - NS120: 4kV standard

- This wall pack series is suitable for ambient temperature range of -40°C to +50°C. Available in color temperatures of 4 000 K, 5 000 K or 3CCT selectable (3 000/4 000/5 000 K) with a lumen per watt ratio of 140 lm/W to 152 lm/W depending on the lumen package.
- The color temperature of the fixture is set by default at 4 000 K and can be changed on the field.

• Compliances

- Wet location
- IP65
- Meets requirements of ICES-005 issue 5 for class B products
- cULus
- IK06
- BC Hydro



OVERVIEW

Light source	LED
Watts (W)	25/30/40, 60/80/100 30, 40, 60, 80, 120
Lumens output (lm)	3 625 - 17 885
Efficiency (lm/W)	140 - 152
Color temperature (K)	3CCT (3 000/4 000/5 000) 4 000, 5 000
CRI	> 80

¹ Integrated photocell, multi-volt driver, CCT and Power selectable on some configurations. Consult Quick ship and technical specification table for more details.



quick ship



power selectable¹

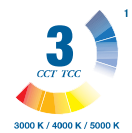

wet location



ICES 005



IK06



Not all products are qualified on the DLC QPL. To view our DLC qualified products, please consult the DLC Qualified Products List at www.designlights.org/search.

QUICK SHIP AND TECHNICAL SPECIFICATION TABLE  1

Order code	Model number	DLC unique ID	Watts (W)	Volts (V)	Color temp. (K) ²	Lumen output (lm) ³	Efficiency (lm/W)	Photo-cell ⁴	CRI	Life L70 (hrs) ⁵	Tested hours LM-80 (hrs) ⁵	Calculated TM21 (hrs) ⁵	Finish	Dimming	B.U.G.	LED current (mA)	Power factor	THD (%)	Case qty (master)
Power Select, CCT Select and Integrated Photocell⁶																			
68314	WPS-PS40-Q-3C	PLW61NEJG50K	25/30/40	120-347	3000/4000/5000	3875/4500/5800 ³	141	Yes	>80	54 000	9 000	173 600	Bronze	Yes	B1U3G4	850	≥0.9	≤20	1
68315	WPS-PS100-Q-3C	PLF7PYF9LCSH	60/80/100	120-347	3000/4000/5000	9300/12000/14500 ³	137	Yes	>80	54 000	9 000	173 600	Bronze	Yes	B1U3G4	2 100	≥0.9	≤20	1
Single Power, Single CCT and Integrated Photocell⁶																			
68524	WPS-NS30-W-40K/P127		29	120-277	4 000	4 200	150	Yes	>80	54 000	9 000	173 600	Bronze	Yes	B1U3G5	230	≥0.9	≤20	1
68525	WPS-NS30-W-50K/P127		29	120-277	5 000	4 300	148	Yes	>80	54 000	9 000	173 600	Bronze	Yes	B1U3G5	230	≥0.9	≤20	1
Single Power and Single CCT																			
68490	WPS-NS40-W-40K	PLVM09BUX07G	40	120-277	4 000	6 004	142	No	>80	54 000	9 000	173 600	Bronze	Yes	B1U3G4	354	≥0.9	≤20	1
68491	WPS-NS40-W-50K	PL3ULW7TEV5H	40	120-277	5 000	6 034	144	No	>80	54 000	9 000	173 600	Bronze	Yes	B1U3G4	354	≥0.9	≤20	1
68492	WPS-NS60-W-40K	PL6EFOU7BPWB	60	120-277	4 000	8 458	146	No	>80	54 000	9 000	173 600	Bronze	Yes	B1U3G5	486	≥0.9	≤20	1
68493	WPS-NS60-W-50K	PL01JETYSQ80	60	120-277	5 000	8 611	147	No	>80	54 000	9 000	173 600	Bronze	Yes	B1U3G5	486	≥0.9	≤20	1
68497	WPS-NS80-W-40K	PLVXL8TOP2UF	80	120-277	4 000	11 242	146	No	>80	54 000	9 000	173 600	Bronze	Yes	B1U4G5	645	≥0.9	≤20	1
68498	WPS-NS80-W-50K	PL2AZJG3LORQ	80	120-277	5 000	11 446	148	No	>80	54 000	9 000	173 600	Bronze	Yes	B1U4G5	645	≥0.9	≤20	1
Single Power, CCT Select and Integrated Photocell⁶																			
68316	WPS-NS120-Q-3C	PLYRMZY3AY3	120	120-347	3000/4000/5000	16 943	137	Yes	>80	54 000	9 000	173 600	Bronze	Yes	B2U4G5	2 600	≥0.9	≤20	1

¹ **QUICK SHIP:** Product availability is subject to change without notice. Please contact your Stanpro customer service representative to confirm inventory levels at time of order.

² Typical color temperature range: +/- 5 %.

³ Lumen values are derived from photometric testing. Initial lumens range: +/- 10 %.

⁴ Lumen values are based on 4 000 K default settings. Please refer to Quick ship Technical Specification Table for more details on other color temperatures.

⁵ Life hours are derived from IESNA LM-80-08 testing report and projected per IESNA TM-21-11 extrapolations.

⁶ Integrated ON/OFF photocell that can be easily disabled.

ACCESSORIES (order separately)

Order code	Description
68370	18" Bronze metal backplate
68371	Bronze glare shield
68372	Stainless Steel wireguard



ORDERING GUIDE

Series	Lumen package (W)	Volts (V)	Color temp. (K)	Casting color	Options
WPS	PS40 - 25/30/40 PS100 - 60/80/100 NS120 - 120	Q - 120-347	3C - 3 000/4 000/5 000	BR - Bronze (standard) BK - Black WH - White	KV - 10 kV surge Protection PC - Polycarbonate lens
	NS30 ¹ - 29 NS40 - 40 NS60 - 60 NS80 - 80	W - 120-277	40K - 4 000 50K - 5 000	SP- Special color	KV - 10 kV surge Protection P127 ¹ - Button type photocell 120-277 V PC - Polycarbonate lens

¹ Button type photocell 120-277 V comes standard with the "NS30" lumen package.

Data is based upon tests performed in a controlled environment. Actual performance can vary depending on operating conditions. All products are subject to change or may be discontinued any time without notice.

DIMENSIONS

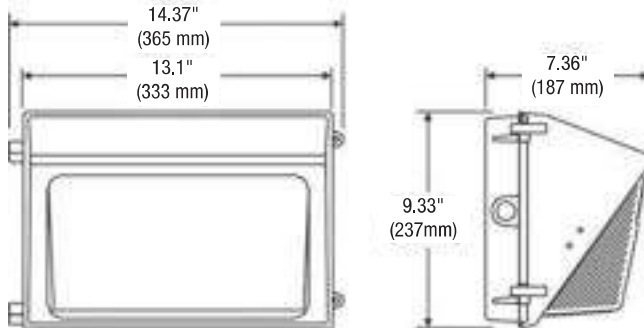

BACKPLATE

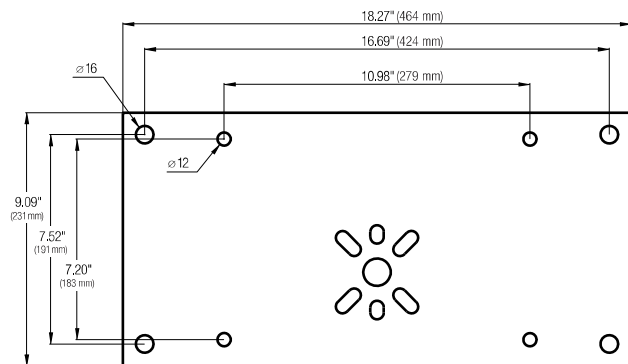

GLARESHIELD

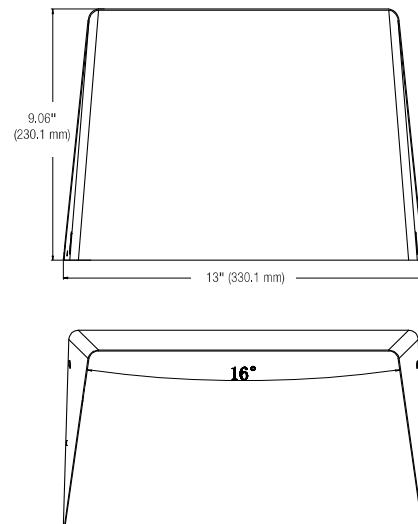

WIREGUARD

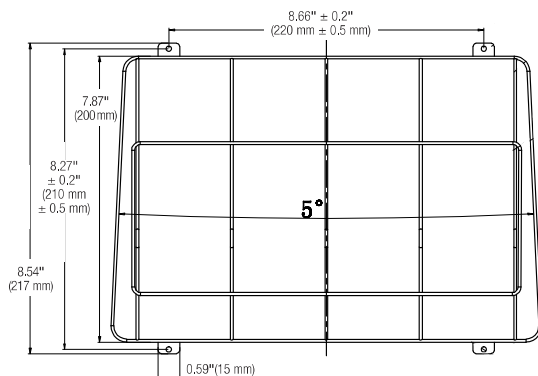

Data is based upon tests performed in a controlled environment. Actual performance can vary depending on operating conditions. All products are subject to change or may be discontinued any time without notice.

LUMINAIRE CLASSIFICATION SYSTEM (LCS) GRAPH

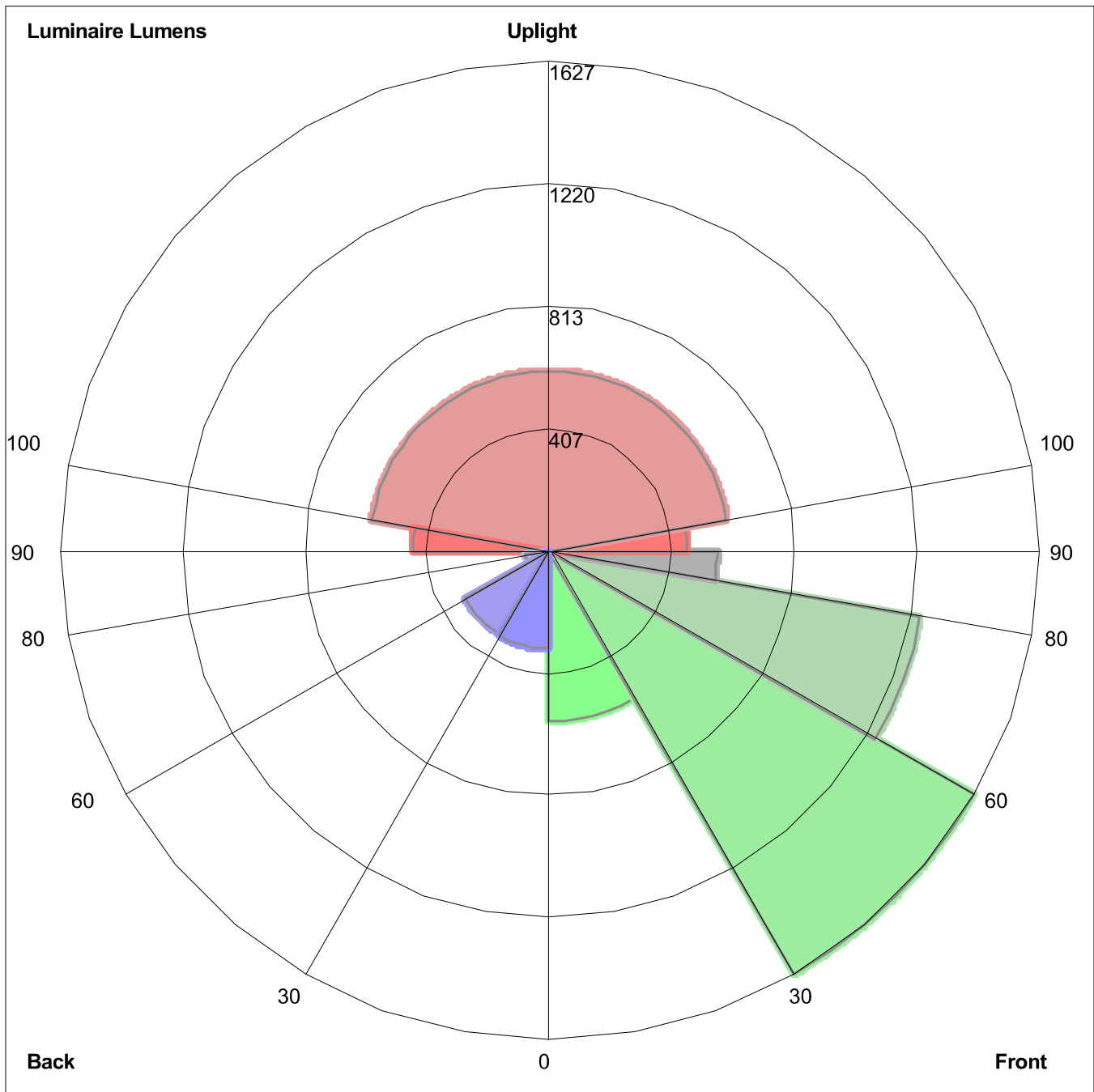

Luminaire Lumens:
Front: Low=566.0, Medium=1626.5, High=1251.8, Very High=558.0
Back: Low=327.7, Medium=323.2, High=79.4, Very High=11.6
Uplight: Low=456.3, High=599.7

BUG Rating : B1-U4-G4

FIXTURE CUT SHEET

TYPE C

Pauluhn DLL LED luminaires

For land-based drilling

Cl. I, Div. 2, Groups A, B, C, D
Cl. I, Zone 2
Cl. II, Div. 2, Groups F, G
Cl. III

UL Listed
CSA Certified
Marine & Wet Locations
NEMA 4X; IP66

2L

2L

The Pauluhn™ DLL linear LED is specifically designed to replace fluorescent T12, T8 and T5HO lighting on land-based and offshore drilling platforms. The rugged and durable design features the industry's most versatile and flexible mounting options. The Pauluhn DLL is the ideal solution for high vibration, impact and hose down in drilling applications.

Model	Typical lumens	Watts	Lumens per watt	Equivalent HID luminaire	Typical energy savings / lifetime
DLL2	3,958	32	124	T12HO	Up to 63%
				T8HO	Up to 59%
				T5HO	Up to 47%
				T12	Up to 36%
				T8	Up to 25%
DLL4	7,900	83	130	T5	Up to 9%
				T12HO	Up to 58%
				T8HO	Up to 54%
				T5HO	Up to 43%
				T12	Up to 37%
				T8	Up to 22%
				T5	Up to 10%

Applications:

- Land-based and offshore rigs; areas include: derrick, mast, SCR house, top drive, operator's house, power and pump stations

Features:

- High efficacy: up to 120 LPW
- 40°C to +65°C ambient operating temperature (standard model)
- Low profile (<3" height)
- Versatile ceiling/swivel, wall, flush, pole and pendant mounting options
- Wide and narrow optics for uniform illumination in control room and drill mast
- Four points of secondary retention
- 2,000 PSI high pressure hose rated
- High vibration resistance
- Emergency battery back-up (90 minutes) and surge protection options (up to 10 kV) [Ⓐ]
- DesignLights Consortium® Qualified (some models are not DLC qualified) [Ⓑ]
- 5 year fixture warranty

Standard materials:

- Housing – copper-free aluminum; Corro-free epoxy powder coat (optional)
- Lens – clear polycarbonate; diffused polycarbonate

Photometrics:

- Complete photometrics can be found at www.crouse-hinds.com/photometrics

Temperature performance data:

Ambient temp. °C	Min. temp. supply wire °C	Simultaneous rating		
		Class I, Div. 2	Class II, Div. 2	Class I, Div. 2; Class II, Div. 2
40	60	T6	T6	T6
55	75	T5	T5	T5
65	90	T5	T5	T5



Mounting (ordered separately):

Versatile mounting options:

- Flush back mount
- Swivel/ceiling back mount
- Offset ceiling mount
- Offset wall mount
- Pole mount
- Pendant mount

Easily retrofit to:

- Existing Pauluhn DuraPro and MagnaPro fluorescent light fixtures
- Rig-A-Lite and Snelson C1D2 fluorescent lighting fixtures

Certifications and compliances:

NEC:

- Class I, Division 2, Groups A, B, C, D
- Class I, Zone 2
- Class II, Division 2, Groups F, G
- Class III
- NEMA 4X, IP66
- Marine and wet locations

UL standards:

- UL844 – Electrical Fixture Hangers for Hazardous Locations
- UL1598 – Luminaire
- UL1598A – Luminaire for Installation on Marine Vessels
- UL924 – Emergency Lighting

CSA standard:

- C22.2 No. 137

Additional certifications:

- ABS design assessed

Electrical ratings:

	DLL2	DLL4
Lumen output	3,958	7,900
Frequency	50/60 Hz	50/60 Hz
Voltage	100-277 VAC, 108-250 VDC; 347-480 VAC	

Model	Voltage	Current (A)	Watts	Power factor	THD
DLL2/UNV1	100	0.33	32.5	0.92	<20%
DLL2/UNV1	277	0.13	34.3	0.92	<20%
DLL2/UNV34	347	0.10	32.2	0.92	<20%
DLL2/UNV34	480	0.07	34.5	0.92	<20%
DLL4/UNV1	100	0.63	63.4	0.92	<20%
DLL4/UNV1	277	0.23	62.5	0.92	<20%
DLL4/UNV34	347	0.18	61.4	0.92	<20%
DLL4/UNV34	480	0.13	63.9	0.92	<20%

Weights:

Model	Lbs.	Kg.
DLL2	12.50	5.70
DLL4	22.50	10.20

[Ⓐ] One year warranty.

[Ⓑ] Refer to www.designlights.org Qualified Products List under Family Models for full listing details. Not all models are approved for all application categories.

Pauluhn DLL LED luminaires

For land-based drilling

Cl. I, Div. 2, Groups A, B, C, D
Cl. I, Zone 2
Cl. II, Div. 2, Groups F, G
Cl. III

UL Listed
CSA Certified
Marine & Wet Locations
NEMA 4X; IP66

2L

2L

Designed for drilling. Pauluhn DLL linear LED luminaires are engineered to handle demanding conditions faced on land-based drilling rigs. The DLL stands up to high vibration, hose down, shock and impact, while delivering long life and high lumen performance for up to 20 years.

Custom optics:

- Standard wide (120°) beam spread for control room and indoor application maximizes illumination on wall panels
- Narrow (80°) beam spread option for high mast/derrick application avoids spillage and light loss

Comprehensive certification:

- Single model certified for use in Class I, Division 2 and Class II, Division 2 harsh and hazardous applications

Quick & easy installation:

- Easy access to drivers and wiring
- No custom brackets or hardware needed
- Seven mounting options available
- Easily retrofit to Pauluhn DuraPro and MagnaPro, Rig-A-Lite and Snelson



Slim profile:

- 2.7" fixture height (excluding mounting brackets)
- Perfect for mounting in confined or low height areas

Built to last:

- Ingress protection from hose down water or diesel fuel in harsh operational conditions – passed 2,000 PSI high pressure test
- Vibration-, impact- and shock-resistant – passed 5G, 3-axis vibration test
- 60,000 hour lifetime at 55°C ambient



Pauluhn DLL LED luminaires

For land-based drilling

Cl. I, Div. 2, Groups A, B, C, D
Cl. I, Zone 2
Cl. II, Div. 2, Groups F, G
Cl. III

UL Listed
CSA Certified
Marine & Wet Locations
NEMA 4X; IP66

2L

2L

Ordering information:

Part number example

DLL4N/UNV1 S903 TF P EM1

DLL	4	N	/UNV1	S903	TF	P	EM1
Series	Optics		Lens		Emergency back-up		
DLL Pauluhn DLL linear LED luminaire	BLANK Wide (120°)	N Narrow (80°)	S903 Clear polycarbonate	BLANK Standard model (no battery back-up)			
	Voltage		S903D Diffused polycarbonate	EM1Ⓞ Integrated emergency battery back-up			
	/UNV1 100-277 VAC, 10E-250 VDC		Options	EM Remote emergency kit			
Length / lumens			TF Pull wire included in fixture				
4 4 ft. length, 7,900 lumens			Finish				
2 2 ft. length, 3,958 lumens			BLANK Natural aluminum				
			P Painted (gray, epoxy)				
			WH Painted (white, epoxy)				

Accessories (ordered separately):

Description	Cat. #	Description	Cat. #
• Flush/back mount back plate.....	DP1057MTK	• Pendant mount kit.....	PEND HAZ KIT
<i>Compatible with DuraPro</i>		• Safety chain kit.....	SS KIT
• Ceiling/swivel mount.....	DP1050MTK	• 1 amp driver replacement kit, 100-277 VAC for 4 ft. linear.....	VMVL/UNV1 80W 1A KIT
<i>Compatible with DuraPro</i>		• 1 amp driver replacement kit, 347-480 VAC for 4 ft. linear.....	VMVL/UNV34 80W 1A KIT
• Ceiling/wall mount offset.....	DP1053MTK	• 0.5 amp driver replacement kit, 100-277 VAC for 2 ft. linear.....	VMVL/UNV1 80W 0.5A KIT
<i>Compatible with DuraPro</i>		• 0.5 amp driver replacement kit, 347-480 VAC for 2 ft. linear.....	VMVL/UNV34 80W 0.5A KIT
• Ceiling mount bracket and adapter kit.....	MP1054MTK KIT		
<i>Compatible with MagnaPro</i>			
• Offset wall mount.....	DP1052MTK		
<i>Compatible with DuraPro</i>			
• Pole mount kit, 1.25" conduit.....	PM KIT 1.25		
• Pole mount kit, 1.50" conduit.....	PM KIT 1.5		
• Pole mount kit, 2.00" conduit.....	PM KIT 2.0		

Dimensions and mounting options:

Technical drawings showing dimensions for DLL4 and DLL2 luminaires. Dimensions are provided in inches and millimeters.

DLL4 Dimensions: (68,58) 2.70" (1329,1) 52.33" (157,9) 6.22"

DLL2 Dimensions: (68,58) 2.70" (719,6) 28.33"

Mounting options shown:

- Offset wall DP1052MTK
- Flush ceiling DP1057MTK
- Offset ceiling DP1053MTK
- Ceiling/swivel DP1050MTK
- Ceiling and adapter MP1054MTK KIT
- Pole mount PM KIT 1.25/1.5/2.0
- Pendant mount PEND HAZ KIT

Ⓞ One year warranty. Remote EM kit also available, 120-277 VAC only. Available with 4 ft. model only.

Pauluhn DLL LED luminaires

For land-based drilling

Cl. I, Div. 2, Groups A, B, C, D
Cl. I, Zone 2
Cl. II, Div. 2, Groups F, G
Cl. III

UL Listed
CSA Certified
Marine & Wet Locations
NEMA 4X; IP66

2L

Mounting options:

Ceiling/swivel mount DP1050MTK

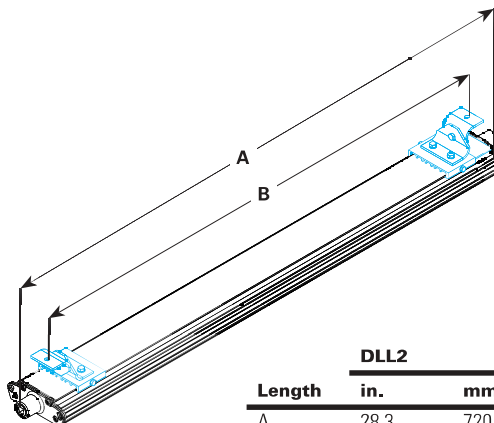
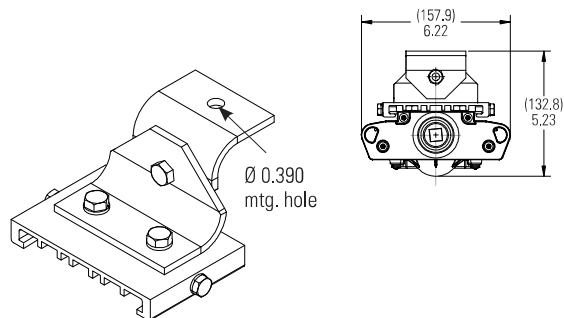

Length	DLL2		DLL4	
	in.	mm.	in.	mm.
A	28.3	720	52.3	1329
B	9-27	222-681	9-51	222-1289

Pole mount PM KIT 1.25/1.5/2.0

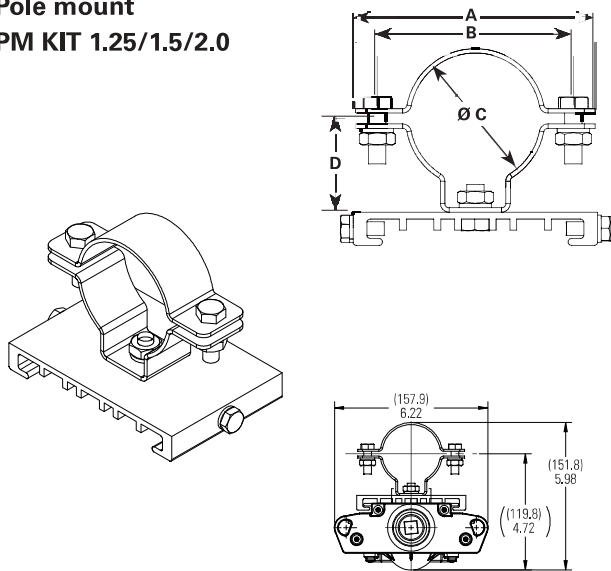

Configuration	ALL MEASUREMENTS IN INCHES			
	A	B	C	D
PM KIT 1.25	4.331	3.543	1.680	1.693
PM KIT 1.5	3.740	2.953	2.000	1.535
PM KIT 2.0	3.386	2.598	2.360	1.378

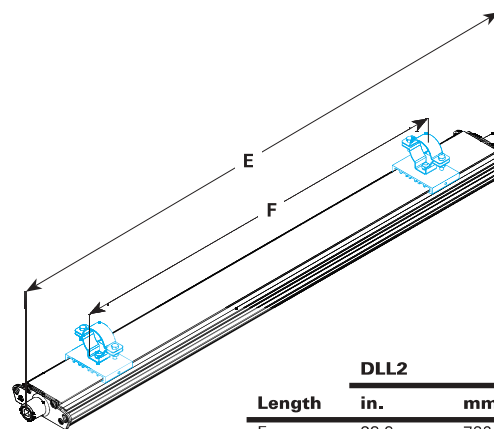

Length	DLL2		DLL4	
	in.	mm.	in.	mm.
E	28.3	720	52.3	1329
F	12-21	305-533	24-45	610-1143

MagnaPro mount MP1054MTK KIT

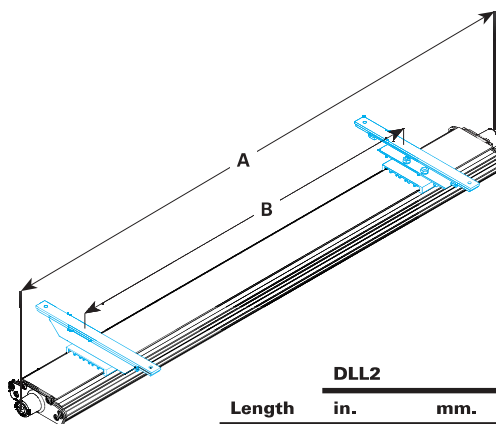
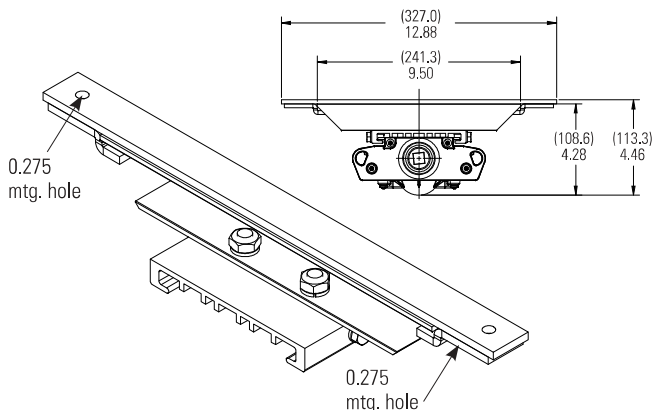

Length	DLL2		DLL4	
	in.	mm.	in.	mm.
A	28.3	720	52.3	1329
B	12-22	305-559	24-46	610-1168

Pauluhn DLL LED luminaires

For land-based drilling

Cl. I, Div. 2, Groups A, B, C, D
Cl. I, Zone 2
Cl. II, Div. 2, Groups F, G
Cl. III

UL Listed
CSA Certified
Marine & Wet Locations
NEMA 4X; IP66

2L

2L

Mounting options (continued):

Offset wall DP1052MTK

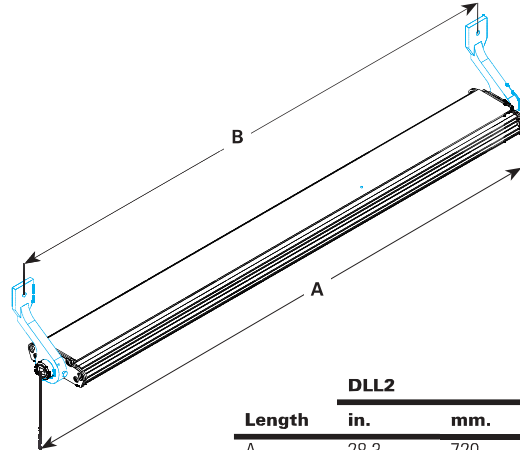
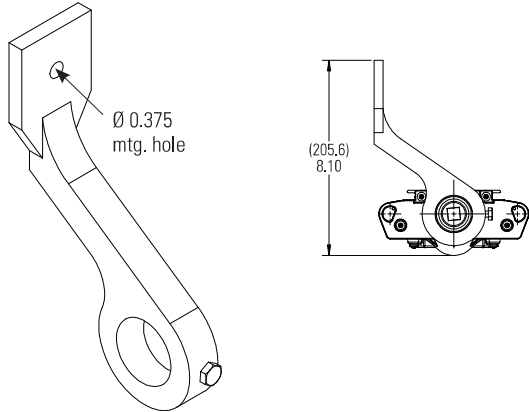

Length	DLL2		DLL4	
	in.	mm.	in.	mm.
A	28.3	720	52.3	1329
B	26.3	669	50.3	1278

Offset ceiling/wall mount DP1053MTK

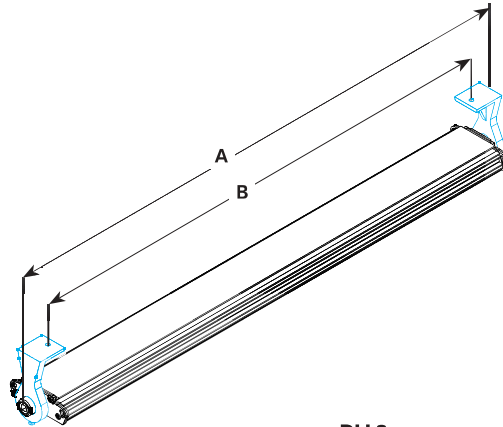
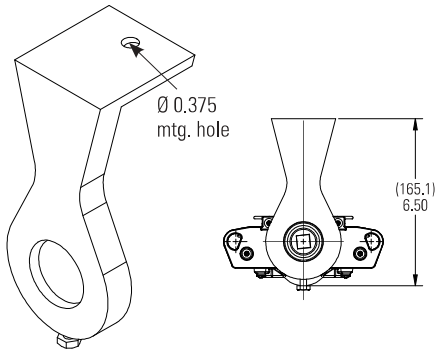

Length	DLL2		DLL4	
	in.	mm.	in.	mm.
A	28.3	720	52.3	1329
B	26.3	584	47.0	1194

Flush ceiling DP1057MTK

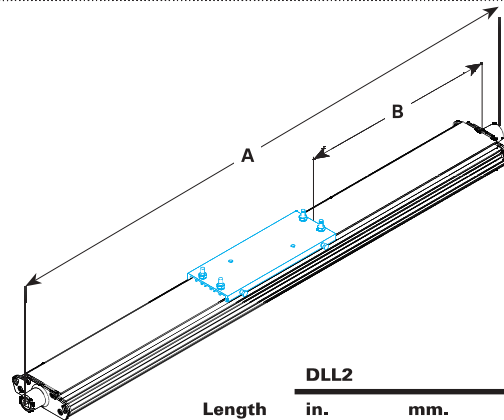
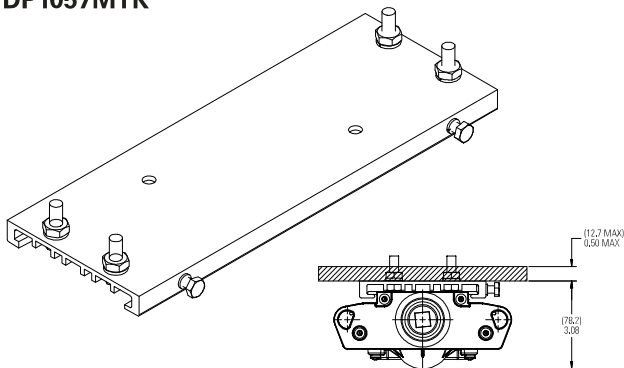

Length	DLL2		DLL4	
	in.	mm.	in.	mm.
A	28.3	720.0	52.3	1329.0
B	6.2	157.5	18.2	462.0

Pauluhn DLL LED luminaires

For land-based drilling

Cl. I, Div. 2, Groups A, B, C, D
Cl. I, Zone 2
Cl. II, Div. 2, Groups F, G
Cl. III

UL Listed
CSA Certified
Marine & Wet Locations
NEMA 4X; IP66

2L

2L

Mounting options (continued):

Pendant mount – Class I, Division 2 only
PEND HAZ KIT

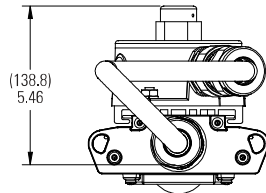
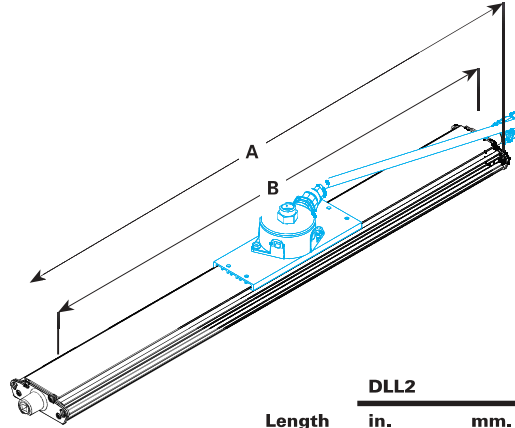
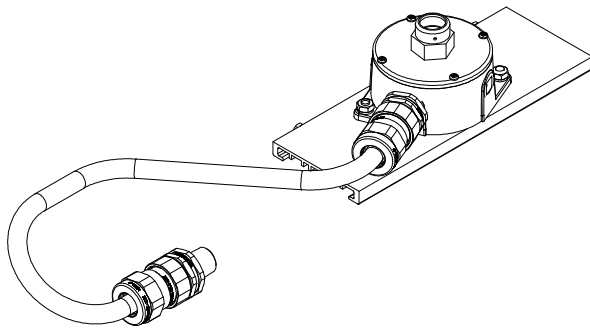

Length	DLL2		DLL4	
	in.	mm.	in.	mm.
A	31.7	805	55.8	1418
B	28.3	720	52.3	1329
C	4.2	108	16.0	406
D	12.2	310	24.0	610
E	34.9	886	58.9	1495

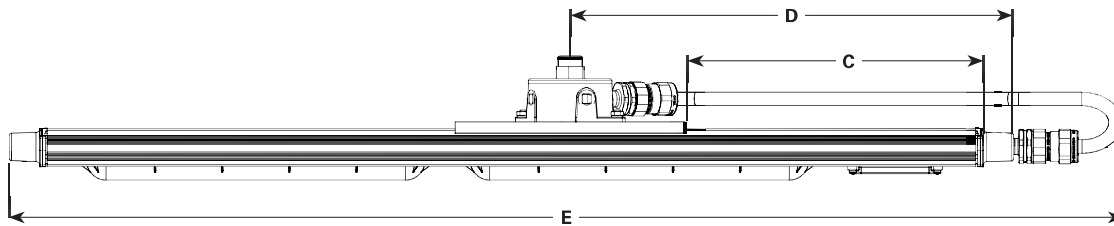

Pauluhn DLL LED luminaires

Integral battery back-up

Cl. I, Div. 2, Groups A, B, C, D
Cl. II, Div. 2, Groups F, G

UL Listed
CSA Certified
Wet Locations
Type 4X; IP66

2L

2L

Pauluhn DLL linear LED luminaires are available with an integral battery back-up module. Virtually the same size as the standard 4 foot model and 90 minutes of emergency lighting to keep your facility and personnel safe.



Model	EM output	Normal output
DLL4/UNV1 S903 EM1	1,400 lumens (100-277V)	6,720 lumens (100-277V)

Applications:

- Egress and emergency lighting for areas requiring uninterrupted lighting during power failure
- Hazardous rated indoor and outdoor emergency lighting in manufacturing plants, heavy industrial, chemical and petrochemical facilities, platforms, loading docks and parking areas

Features:

- Operating ambient: 0°C to +40°C
- 90-minute run time in emergency mode
- 6,720 lumen output for normal operation; 1,400 lumen output in emergency mode
- 50,000 hours rated life at 40°C
- IP66 rated enclosure
- LED indicator to check battery operation
- Nickel cadmium battery
- 1 year warranty

Certifications and compliances:

NEC/CEC:

- Class I, Division 2, Groups A, B, C, D
- Class II, Division 2, Groups F, G
- Wet locations, Type 4X, IP66

UL standards:

- UL844 – Hazardous (Classified)
- UL1598 – Luminaires
- UL1598A – Marine
- UL924 – Emergency Lighting

CSA standard:

- CSA C22.2 Nos. 137, 141

Electrical ratings:

	EM output	Normal output
Voltage	120	277
Amperage at 120 VAC	0.480	0.212
Wattage at 120 VAC	57.8	57.7
Lumen output	1,400	6,720
Frequency	50/60 Hz	50/60 Hz
Power factor at 100 VAC	>0.90	>0.90
THD	6.58	11.70

Temperature performance data:

Ambient temp. °C	Min. temp. supply wire °C	Simultaneous rating		
		Class I, Div. 2	Class II, Div. 2	Class I, Div. 2; Class II, Div. 2
40	60	T5	T6	T5

Photometrics:

- Complete photometrics can be found at www.crouse-hinds.com/photometrics

Dimensions:

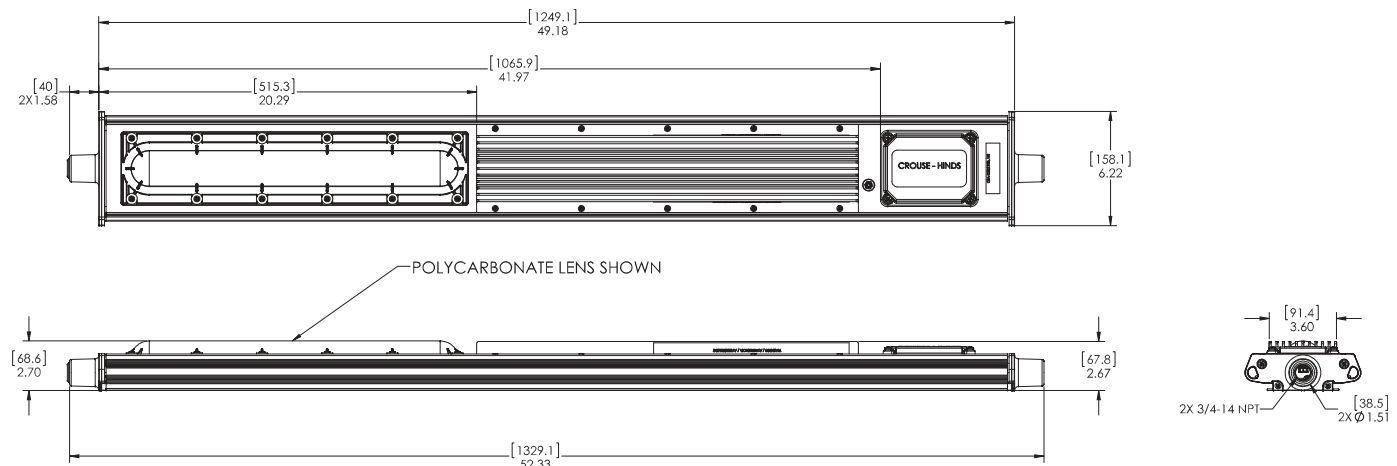

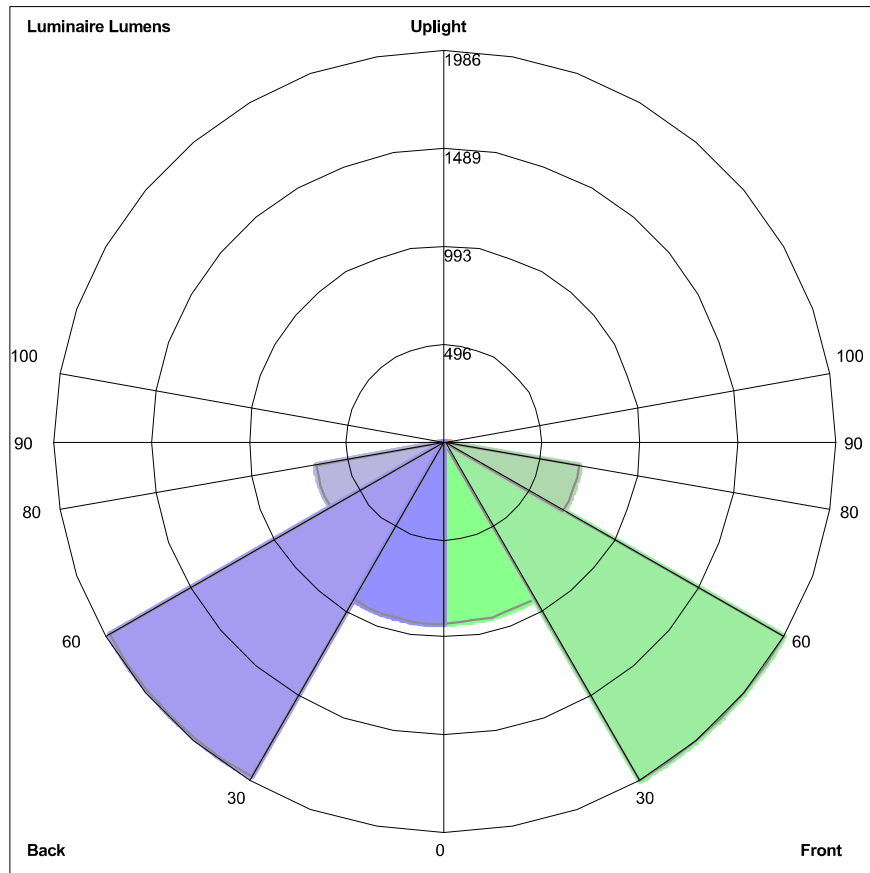

Luminaire Lumens:
 Front: Low=921.0, Medium=1985.6, High=698.7, Very High=29.2
 Back: Low=925.1, Medium=1963.4, High=664.7, Very High=26.5
 Uplight: Low=4.7, High=1.2

BUG Rating : B2-U1-G1

FIXTURE CUT SHEET

TYPE D



Dialight® LED High Bay & Low Bay

Technical Specification Sheet - Americas

Vigilant® LED High Bay - UL / CSA

Corded Model & Integrated Wiring Box Model

Corded Model



Mechanical Information:

Fixture weight:

18 lbs (8,16kg)

Shipping weight:

24 lbs (10,8kg)

Mounting:

3/4" NPT - top
Various Kits

Power Cord:

10' 18 AWG ST00W

Patent pending

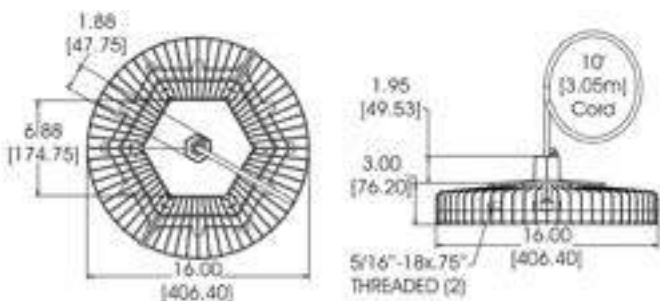

Integrated Wiring Box Model

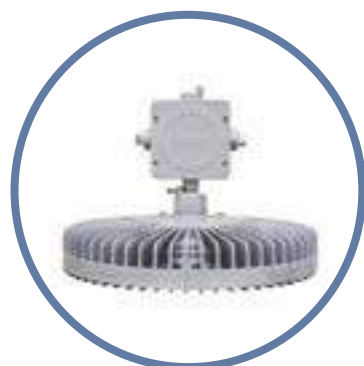

Mechanical Information:

Fixture weight:

20 lbs (9 kg)

Shipping weight:

26 lbs (12 kg)

Mounting:

3/4" NPT or Hook

Wiring Box Cable Entries:

(2x) 3/4" NPT

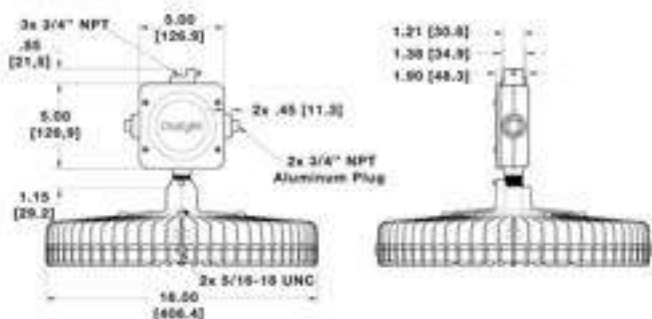

Dimensions in inches (mm)

WARNING - INSTALLATION & SECONDARY RETENTION. Use of any Dialight products without proper installation (including secondary retention / netting) and periodic inspections could cause severe injury or death. Dialight recommends that all installations should use secondary retention / netting (appropriate to the installation environment) where applicable. It is the exclusive responsibility of the contractor, installer and/or end-user to: (a) determine the suitability of the product for its intended application; and, (b) ensure that the product is safely installed (with secondary retention / netting where appropriate) and in compliance with all applicable laws and regulations. To the extent permissible under applicable laws, Dialight disclaims all liability for personal injury and/or other damage resulting from any dislodgment or other dislocation of its products.

Certifications & Ratings:

10 year warranty

UL 1598/A

UL 8750

IP66/67

CSA C22.2 No. 250.0-08

NEMA 4X

L70 rated for >150,000 hours

Variable Dimming:

Variable Dimming Control: 0-10 VDC

Dimming Range:

10 VDC = 100% light output

0 VDC = <10% light output

Occupancy Sensor:

Mounting Height:

Up to 40ft

Ingress Protection:

IP66

Electrical Specifications:

Operating Voltage:

100-277 VAC, 120-250 VDC
347-480 VAC

Total system power consumption:

See table

Operating Temp:

-40°F to +149°F (-40°C to +65°C)

Harmonics:

IEC 61000-3-2 Class C

Noise requirement /EMC:

FCC Title 47, Subpart B, Section 15, class A device. RF Immunity; 10V/m, 80MHz-1GHz

Transient protection:

100-277 VAC models tested to withstand up to 8kV/4kA per IEEE C62.41.
347-480 VAC models tested to withstand up to 6kV/3kA per IEEE C62.41

THD:

<20%

Power Factor:

>0.9

Fusing:

Internal

Construction:

Housing:

Copper free aluminum

Finish:

Superior dual coat finish
Sealed polyester topcoat
Chemical-resistant epoxy primer

Lens:

See table

Photometric Information:

CRI:

80

CCT:

5000K (cool white)
4000K (neutral white)

All values typical unless otherwise stated (tolerance +/- 10%)

Vigilant® LED High Bay - UL / CSA

Corded & Integrated Wiring Box



Project Information	
Part Number:	
Project:	
Fixture Type:	Date:

Specifications

Ordering Information

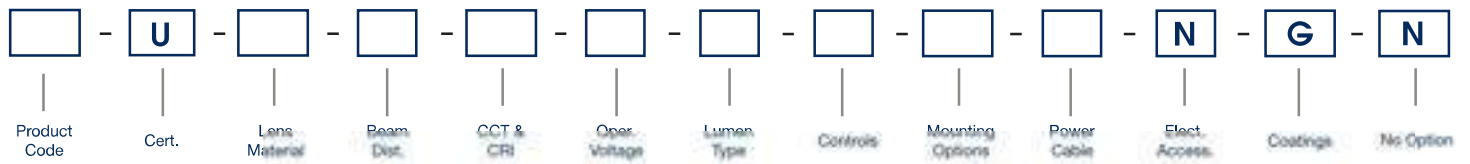

Product Code HC High Bay Integrated Pendant Wiring Box HE High Bay 3/4" NPT	Beam Distribution E Oval M Medium N Narrow W Wide	Lumen Type A 11,600 Lumens B 14,900 Lumens C 19,800 Lumens E 27,500 Lumens	Power Cable N No Cord (HC only) W 10' [3 meter] Power Cable (HE only)
Certification U UL 1598/A, CSA	CCT & CRI C Cool White 5000K - 80 CRI N Neutral White 4000K - 80 CRI	Controls D Dimming (0-10V) N No Dimming (HE only) M Occupancy Sensor (HC only)	Electrical Accessories N No Plug
Lens Material 2 Acrylic - Clear (dry location only) 4 Polycarbonate - Clear 7 Glass - Clear L Polycarbonate Dome - Diffused R Power Wash Glass, Clear	Operating Voltage 2 100-277 VAC / 120-250 VDC 5 347-480 VAC	Mounting Options H Hook N Pendant 3/4" NPT P Pendant 3/4" NPT with Safety Retention Tabs R Safety Retention Tabs with Hook	Coatings G Gray (RAL 7040)
			Option N No Option

Notes

- 1) Lumen type based on using a glass lens. See tables for lumens when changing lenses.
- 2) When ordering occupancy sensor, use prefix HC.
- 3) When ordering option HC, Controls = (D) Dimming or (M) Occupancy Sensor.

DISCLAIMER. All product information provided is, to the best of Dialight's knowledge, accurate as of the date of publication. When ordering, refer to www.dialight.com for current versions of: (a) relevant product documentation (including the relevant product data sheets); (b) Dialight terms and conditions of sale; and, (c) the relevant product warranty. To the extent that any contract is deemed formed between Dialight and the purchaser of Dialight products and/or an end-user, versions of documents available at www.dialight.com as at the date of sale shall be the versions incorporated therein. In the event of any discrepancy between this document or information provided at www.dialight.com, the latter shall prevail.

Ordering Information

Vigilant® LED High Bay - Corded Model



Corded Model - 3/4" Conduit - 100-277 VAC / 120-250 VDC								
Part Number	Lumens	Wattage	lm/W	CCT	Lens	Beam Distribution	Hardware Options	Wiring
HEU-7MC2-ENNW-NGN	27,500	185	149	CW	Glass - Clear	Medium	Pendant 3/4" NPT	10' Power Cable
HEU-7MC2-ENPW-NGN	27,500	185	149	CW	Glass - Clear	Medium	Pendant 3/4" NPT with Safety Tabs	10' Power Cable
HEU-7MC2-EDNW-NGN	27,500	185	149	CW	Glass - Clear	Medium	Pendant 3/4" NPT	10' Power Cable
HEU-4MC2-ENNW-NGN	27,200	185	147	CW	Polycarbonate - Clear	Medium	Pendant 3/4" NPT	10' Power Cable
HEU-2MC2-ENNW-NGN	27,200	185	147	CW	Acrylic - Clear	Medium	Pendant 3/4" NPT	10' Power Cable
HEU-LMC2-ENNW-NGN	27,000	185	146	CW	Polycarbonate Dome - Diffused	Medium	Pendant 3/4" NPT	10' Power Cable
HEU-2WC2-ENNW-NGN	27,000	185	146	CW	Acrylic - Clear	Wide	Pendant 3/4" NPT	10' Power Cable
HEU-7MC2-CNNW-NGN	19,800	130	152	CW	Glass - Clear	Medium	Pendant 3/4" NPT	10' Power Cable
HEU-7MC2-CNPW-NGN	19,800	130	152	CW	Glass - Clear	Medium	Pendant 3/4" NPT with Safety Tabs	10' Power Cable
HEU-7MC2-CDNW-NGN	19,800	130	152	CW	Glass - Clear	Medium	Pendant 3/4" NPT	10' Power Cable
HEU-4MC2-CNNW-NGN	19,600	130	151	CW	Polycarbonate - Clear	Medium	Pendant 3/4" NPT	10' Power Cable
HEU-LMC2-CNNW-NGN	19,400	130	149	CW	Polycarbonate Dome - Diffused	Medium	Pendant 3/4" NPT	10' Power Cable
HEU-7MN2-CNNW-NGN	19,400	130	149	NW	Glass - Clear	Medium	Pendant 3/4" NPT	10' Power Cable
HEU-7MC2-BNNW-NGN	14,900	100	149	CW	Glass - Clear	Medium	Pendant 3/4" NPT	10' Power Cable
HEU-4MC2-BNNW-NGN	14,800	100	146	CW	Polycarbonate - Clear	Medium	Pendant 3/4" NPT	10' Power Cable
HEU-LMC2-BNPW-NGN	14,600	100	146	CW	Polycarbonate Dome - Diffused	Medium	Pendant 3/4" NPT with Safety Tabs	10' Power Cable
HEU-LMC2-BNNW-NGN	14,600	100	146	CW	Polycarbonate Dome - Diffused	Medium	Pendant 3/4" NPT	10' Power Cable
HEU-7MC2-ANNW-NGN	11,500	80	145	CW	Glass - Clear	Medium	Pendant 3/4" NPT	10' Power Cable
HEU-4MC2-ANNW-NGN	11,200	80	144	CW	Polycarbonate - Clear	Medium	Pendant 3/4" NPT	10' Power Cable
HEU-2MC2-ANNW-NGN	11,500	80	144	CW	Acrylic - Clear	Medium	Pendant 3/4" NPT	10' Power Cable
HEU-LMC2-ANNW-NGN	11,400	80	143	CW	Polycarbonate Dome - Diffused	Medium	Pendant 3/4" NPT	10' Power Cable
Corded Model - 3/4" Conduit - 347-480 VAC								
HEU-7MC5-EDNW-NGN	27,500	185	149	CW	Glass - Clear	Medium	Pendant 3/4" NPT	10' Power Cable
HEU-7MC5-ENNW-NGN	27,500	185	149	CW	Glass - Clear	Medium	Pendant 3/4" NPT	10' Power Cable
HEU-7MC5-ENPW-NGN	27,500	185	149	CW	Glass - Clear	Medium	Pendant 3/4" NPT with Safety Tabs	10' Power Cable
HEU-4MC5-ENPW-NGN	27,200	185	147	CW	Polycarbonate - Clear	Medium	Pendant 3/4" NPT with Safety Tabs	10' Power Cable
HEU-7WC5-ENPW-NGN	27,200	185	147	CW	Glass - Clear	Wide	Pendant 3/4" NPT with Safety Tabs	10' Power Cable
HEU-7EC5-ENNW-NGN	25,900	185	140	CW	Glass - Clear	Oval	Pendant 3/4" NPT	10' Power Cable
HEU-4EC5-EMNW-NGN	25,600	185	138	CW	Polycarbonate - Clear	Oval	Pendant 3/4" NPT	10' Power Cable
HEU-7MC5-CDNW-NGN	19,800	130	152	CW	Glass - Clear	Medium	Pendant 3/4" NPT	10' Power Cable
HEU-7MC5-CNHW-NGN	19,800	130	152	CW	Glass - Clear	Medium	Hook	10' Power Cable
HEU-7MC5-CNNW-NGN	19,800	130	152	CW	Glass - Clear	Medium	Pendant 3/4" NPT	10' Power Cable
HEU-LMC5-CNNW-NGN	19,400	130	149	CW	Polycarbonate Dome - Diffused	Medium	Pendant 3/4" NPT	10' Power Cable
HEU-7MC5-BNNW-NGN	14,900	100	149	CW	Glass - Clear	Medium	Pendant 3/4" NPT	10' Power Cable
HEU-7MC5-ADNW-NGN	11,600	80	145	CW	Glass - Clear	Medium	Pendant 3/4" NPT	10' Power Cable
HEU-7MC5-ANNW-NGN	11,600	80	145	CW	Glass - Clear	Medium	Pendant 3/4" NPT	10' Power Cable
HEU-4MC5-ADNW-NGN	11,500	80	144	CW	Polycarbonate - Clear	Medium	Pendant 3/4" NPT	10' Power Cable
HEU-LMC5-ANNW-NGN	11,400	80	143	CW	Polycarbonate Dome - Diffused	Medium	Pendant 3/4" NPT	10' Power Cable

All values typical unless otherwise stated (tolerance +/- 10%)
 0-10V dimming option available for products in the above table. Replace the ninth character **N** with **D**. Ex: HEU-7MC2-ENNW-NGN becomes HEU-7MC2-EDNW-NGN.
 Acrylic lens is dry location only.

DISCLAIMER. All product information provided is, to the best of Dialight's knowledge, accurate as of the date of publication. When ordering, refer to www.dialight.com for current versions of: (a) relevant product documentation (including the relevant product data sheets); (b) Dialight terms and conditions of sale; and, (c) the relevant product warranty. To the extent that any contract is deemed formed between Dialight and the purchaser of Dialight products and/or an end-user, versions of documents available at www.dialight.com as at the date of sale shall be the versions incorporated therein. In the event of any discrepancy between this document or information provided at www.dialight.com, the latter shall prevail.

Beam Distribution



High Bay Medium

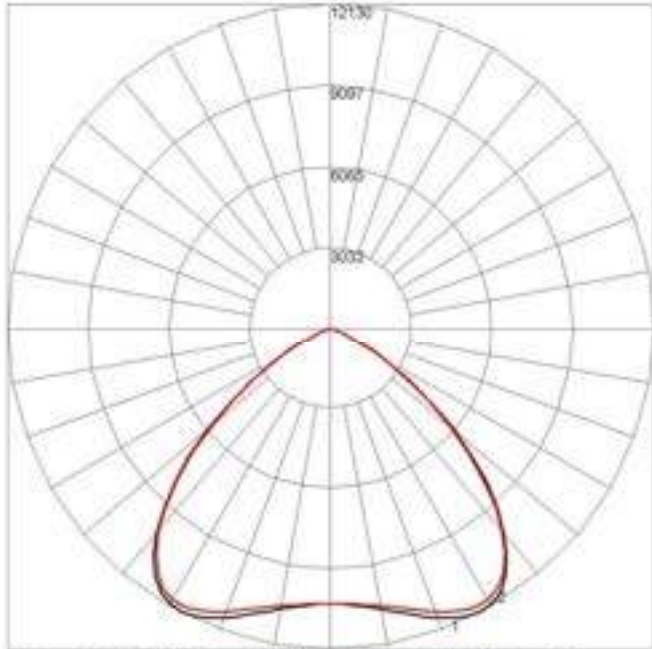

Maximum Candela = 12129.5 - Located At Horizontal Angle = 0, Vertical Angle = 27.5
 # 1 - Vertical Plane Through Horizontal Angles (0 - 180)
 # 2 - Vertical Plane Through Horizontal Angles (90 - 270)

High Bay Wide

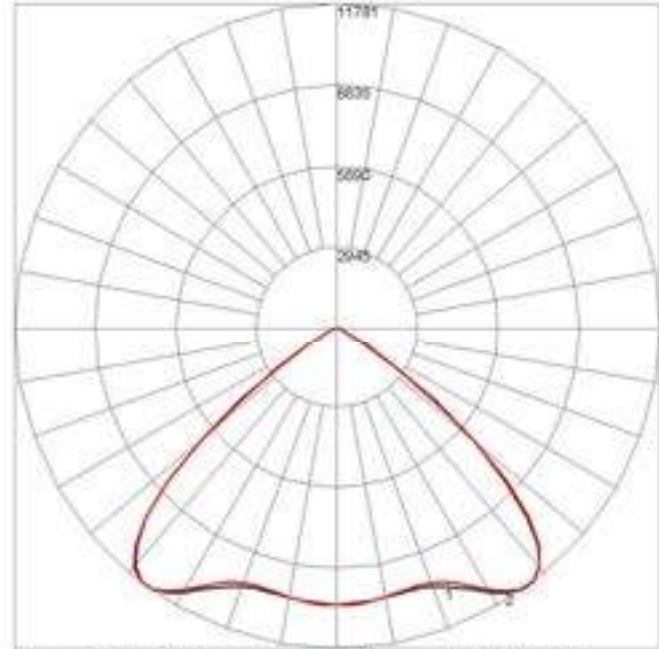

Maximum Candela = 11780.5 - Located At Horizontal Angle = 90, Vertical Angle = 37.5
 # 1 - Vertical Plane Through Horizontal Angles (0 - 180)
 # 2 - Vertical Plane Through Horizontal Angles (90 - 270)

High Bay Oval

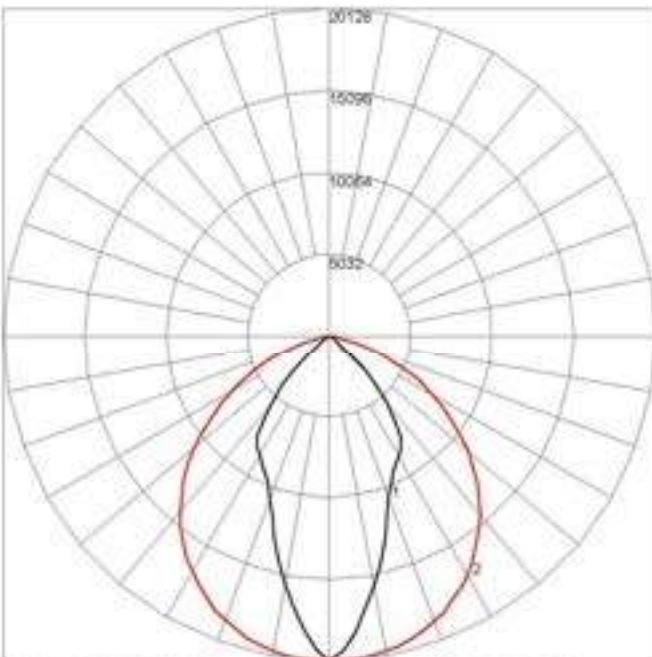

Maximum Candela = 20128.4 - Located At Horizontal Angle = 85, Vertical Angle = 2.5
 # 1 - Vertical Plane Through Horizontal Angles (0 - 180)
 # 2 - Vertical Plane Through Horizontal Angles (90 - 270)

High Bay Narrow

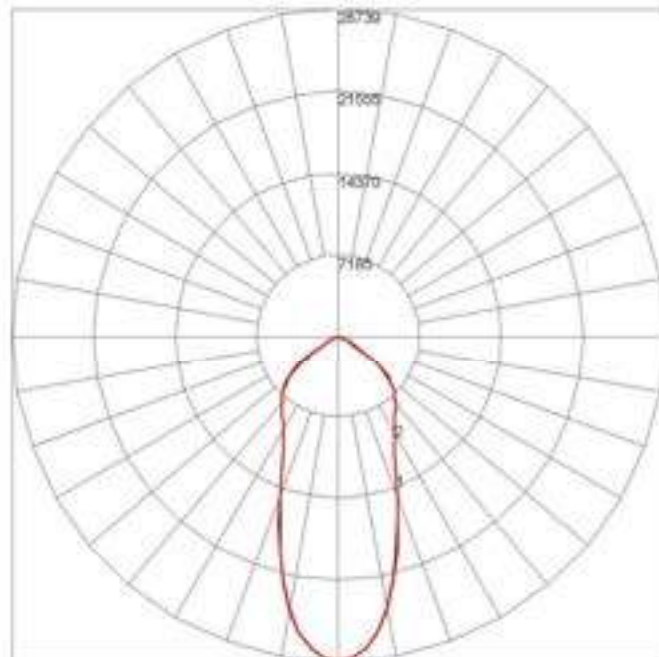

Maximum Candela = 28730.4 - Located At Horizontal Angle = 0, Vertical Angle = 0
 # 1 - Vertical Plane Through Horizontal Angles (0 - 180)
 # 2 - Vertical Plane Through Horizontal Angles (90 - 270)

DISCLAIMER. All product information provided is, to the best of Dialight's knowledge, accurate as of the date of publication. When ordering, refer to www.dialight.com for current versions of: (a) relevant product documentation (including the relevant product data sheets); (b) Dialight terms and conditions of sale; and, (c) the relevant product warranty. To the extent that any contract is deemed formed between Dialight and the purchaser of Dialight products and/or an end-user, versions of documents available at www.dialight.com as at the date of sale shall be the versions incorporated therein. In the event of any discrepancy between this document or information provided at www.dialight.com, the latter shall prevail.

LUMINAIRE CLASSIFICATION SYSTEM (LCS) GRAPH

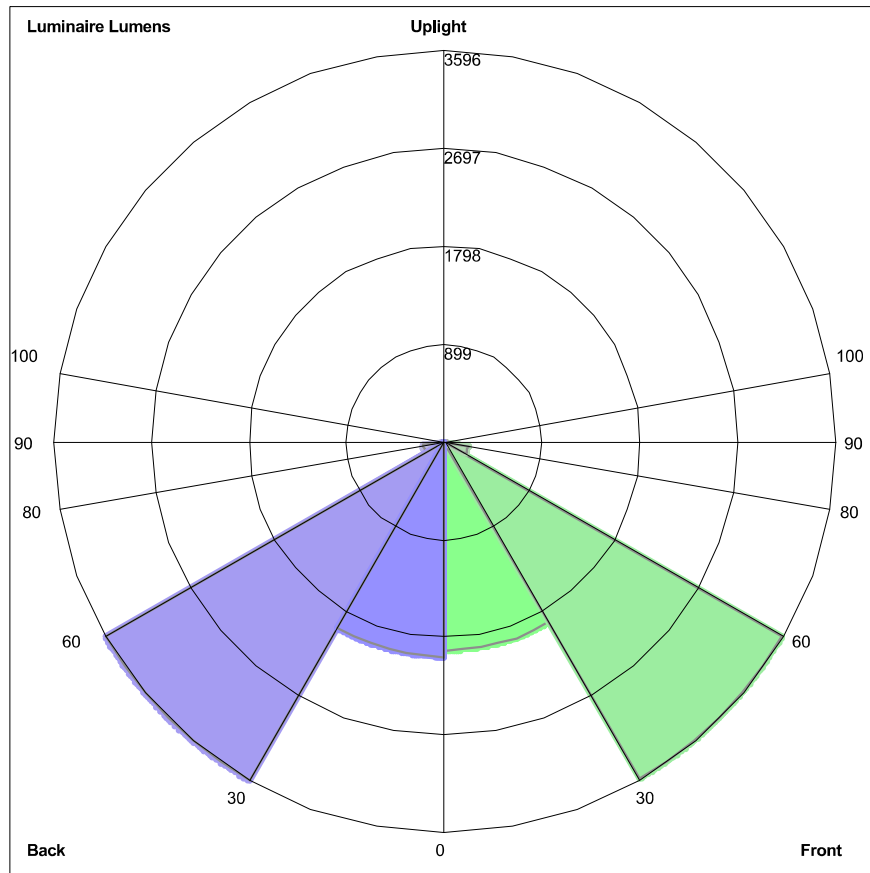

Luminaire Lumens:
Front: Low=1920.3, Medium=3580.5, High=221.0, Very High=4.4
Back: Low=1974.5, Medium=3596.1, High=199.5, Very High=3.8
Uplight: Low=0.0, High=0.0

BUG Rating : B3-U0-G0

FIXTURE CUT SHEET

TYPE E

Pauluhn DFL HID hazardous area floodlights

Cl. I, Div. 2, Groups A, B, C, D
Cl. I, Zone 2, AEx nR II
Cl. II, Div. 1, Groups F, G (250W
max.)
Ex nR II

Marine & Wet Locations
NEMA 4X
IP66

6L

Applications:

- Onshore drilling and exploration
- Pipeline compressor and storage
- Corrosive environments
- Façade security lighting

Features:

- 150-400W high pressure sodium or 175-400W metal halide
- AEx nR, Ex nR restricted breathing rating is standard – restricted breathing offers cooler T-numbers for increased hazardous locations suitability
- NEMA 7x6 butterfly beam floodlight pattern – wide, uniform and far reaching to provide excellent efficiency and more light where you need it
- NEMA Type 4X and IP66 heavy duty, die cast copper-free aluminum construction is designed for use indoors and outdoors in marine and wet locations with stainless steel external hardware suitable for saltwater and corrosive applications
- 40°C, 55°C and 65°C ambient suitability – addresses high ambient common at industrial facilities
- Low ambient capability to -40°C – perfect for colder climates
- Hinged door frame assembly – has captive cover screws for ease of relamping
- Yoke mount design – standard construction provides the greatest mounting flexibility; can be mounted vertically (wall), horizontally (rooftop or floor) or any angle in between
- 3-axis resonance withstand and UL844 vibration compliant – can stand up to the tough jobs
- Precision formed aluminum reflector – superior beam control, distribution and efficiency
- High light output with a low cost of operation – cost-effectiveness in a high wattage floodlight
- Slipfitter adapter for pole mounting and wall mounting bracket available

Certifications and compliances:

- Class I, Division 2, Groups A, B, C, D
- Class I, Zone 2, AEx nR II
- Class II, Division 1, Groups F, G (250W maximum)
- Ex nR II
- UL/cUL844 – Hazardous Locations
- UL/cUL1598 – Luminaires
- UL/cUL1598A – Supplemental Requirements for Luminaires for Installation on Marine Vessels
- 60079-15
- NEMA Type 4X
- IP66
- Marine and wet locations
- ABS



Standard materials and finishes:

- Housing and lens frame – heavy duty die cast copper-free aluminum with Corro-free epoxy powder coat finish
- Lens – heat- and impact-resistant tempered glass
- Gasket – one-piece silicone
- Mounting brackets – aluminum with Corro-free epoxy powder coat finish
- Reflector – precision formed aluminum
- Lamp holder – porcelain
- Hardware – stainless steel

Technical specifications:

- Entries – one 3/4" AEx/Ex gland
- Wind rating – EPA: 2.90 at vertical
- Lamp type – high pressure sodium; probe start metal halide^A; pulse start metal halide (lamps not provided)
- Lamp holder – mogul base
- Ballast – multi-tap 120/208/240/277V, 60 Hz (standard); 220-240V, 50 Hz (optional); tri-tap 120/277/347V (optional); 480V (optional)

Mounting option:

- Yoke mount

Photometrics:

- Complete photometrics can be found at www.crouse-hinds.com/photometrics

^ANot available in the U.S.

Pauluhn DFL HID hazardous area floodlights

Cl. I, Div. 2, Groups A, B, C, D
Cl. I, Zone 2, AEx nR II
Cl. II, Div. 1, Groups F, G (250W max.)
Ex nR II

Marine & Wet Locations
NEMA 4X
IP66

6L

Options:

Description	Suffix
• Lamps included	L ⓐ
• 480V.....	480
<i>Replace /MT in catalog number with /480</i>	
• 230V.....	230
<i>Replace /220 ONLY in catalog number with /230</i>	

Accessories (ordered separately):

Description	Cat. #
• Pole mount slipfitter adapter.....	SFA6
• Wall mount bracket adapter.....	SWB6
• Bull horn, 2 tenon, gray.....	BLHN2
• Bull horn, 3 tenon, gray.....	BLHN3

Ordering information:

Cat. #	Lamp type	Watts	Weight (lbs.)	ANSI lamp type	Zone T-code	Division T-code	Ambient temperature °C	Supply wire °C
DFLMY250/MT 76 S828	Pulse start metal halide	250	42.0	M153	T3	T1	40/55/65	90/90/105
DFLMY400/MT 76 S828	Pulse start metal halide	400	44.0	M155	T3	T1	40/55	105/105
DFLMY320/MT 76 S828	Pulse start metal halide	320	44.0	M154	T3	T1	40/55	105/105
DFLMY250/TT 76ⓐ	Probe start metal halide	250	42.0	M58ⓐ	T3	T1	40/55/65	90/90/105
DFLMY400/TT 76ⓐ	Probe start metal halide	400	44.0	M59ⓐ	T3	T1	40/55	90/105
DFLMY250/220 50 76ⓐ	Probe start metal halide	250	42.0	M58ⓐ	T3	T1	40/55/65	90/90/105
DFLMY400/220 50 76ⓐ	Probe start metal halide	400	44.0	M59ⓐ	T3	T1	40/55	90/105
DFLSY250/MT 76	High pressure sodium	250	40.0	S50	T3	T1	40/55/65	90/90/105
DFLSY400/MT 76	High pressure sodium	400	44.0	S51	T3	T1	40/55	90/105
DFLSY250/TT 76	High pressure sodium	250	40.0	S50	T3	T1	40/55/65	90/90/105
DFLSY400/TT 76	High pressure sodium	400	44.0	S51	T3	T1	40/55	90/105
DFLSY250/220 50 76	High pressure sodium	250	40.0	S50	T3	T1	40/55/65	90/90/105
DFLSY400/220 50 76	High pressure sodium	400	44.0	S51	T3	T1	40/55	90/105

Dimensions (in inches):

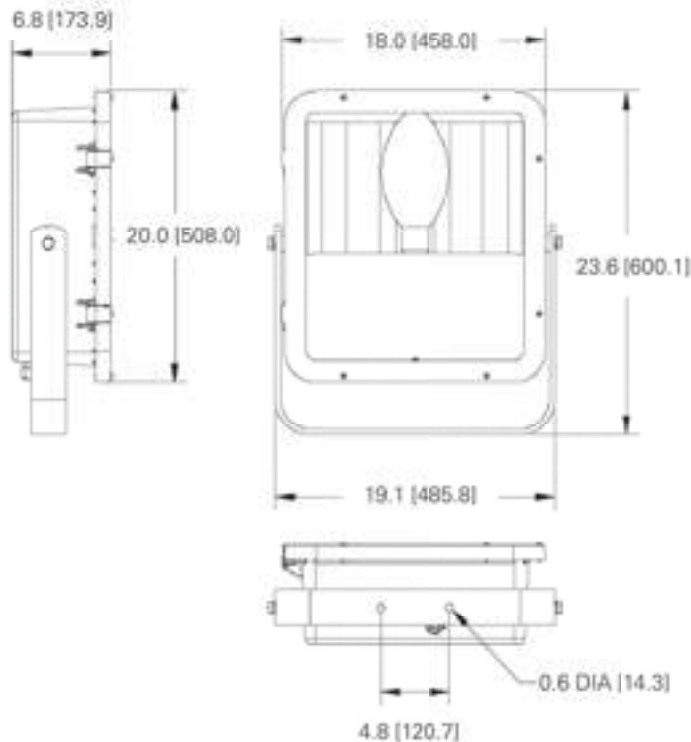

Bull horns – provided with 2 3/8" pole tenon

ⓐ Lamp is not included unless option 'L' is selected.
ⓐ Not available in the U.S.

6L

LUMINAIRE CLASSIFICATION SYSTEM (LCS) GRAPH

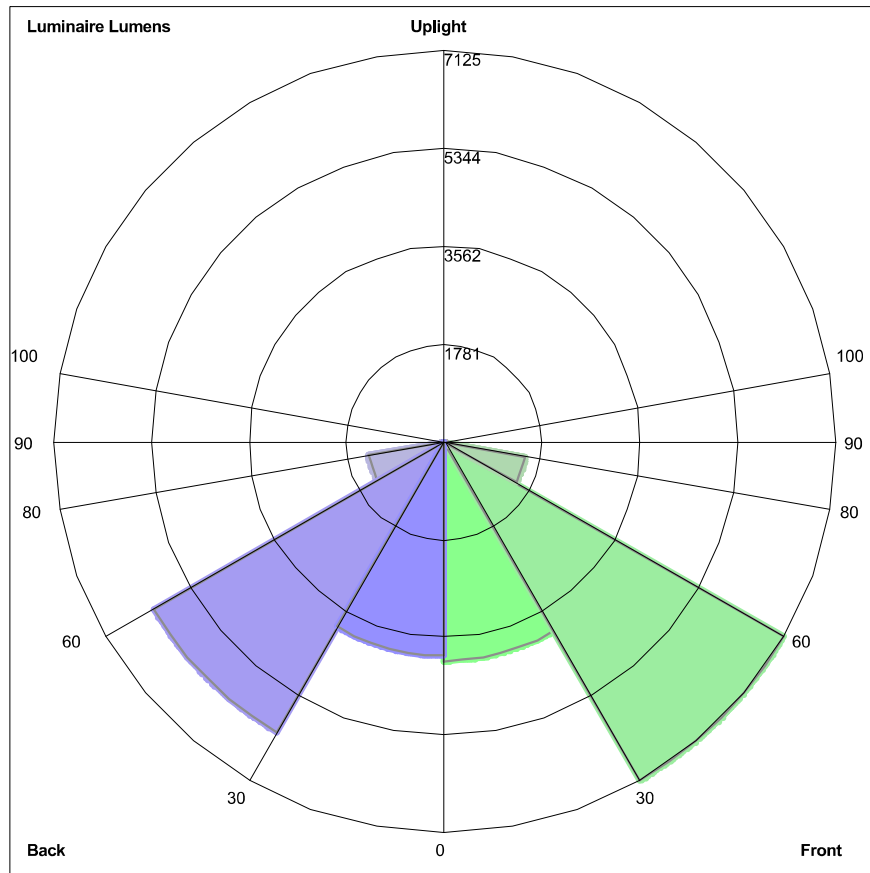

Luminaire Lumens:
Front: Low=3985.6, Medium= 7125.0, High=1500.3, Very High=28.6
Back: Low=3894.8, Medium=6102.1, High=1404.5, Very High=40.2
Uplight: Low=0.0, High=0.0

BUG Rating : B4-U0-G3

FIXTURE CUT SHEET

TYPE F

Pauluhn DLL LED Luminaires

For land-based drilling

Cl. I, Div. 2, Groups A, B, C, D
Cl. I, Zone 2
Cl. II, Div. 2, Groups F, G
Cl. III

UL Listed
CSA Certified
Marine & Wet Locations
NEMA 4X; IP66

2L

2L

The Pauluhn™ DLL linear LED is specifically designed to replace fluorescent T12, T8 and T5HO lighting on land-based and offshore drilling platforms. The rugged and durable design features the industry's most versatile and flexible mounting options. The Pauluhn DLL is the ideal solution for high vibration, impact and hose down in drilling applications.

Model	Typical lumens	Watts	Lumens per watt	Equivalent HID luminaire	Typical energy savings / lifetime
DLL2	3,958	32	124	T12HO	Up to 63%
				T8HO	Up to 59%
				T5HO	Up to 47%
				T12	Up to 36%
				T8	Up to 25%
DLL4	7,900	63	130	T5	Up to 9%
				T12HO	Up to 58%
				T8HO	Up to 54%
				T5HO	Up to 43%
				T12	Up to 37%
				T8	Up to 22%
				T5	Up to 10%

Applications:

- Land-based and offshore rigs; areas include: derrick, mast, SCR house, top drive, operator's house, power and pump stations

Features:

- High efficacy: up to 120 LPW
- 40°C to +65°C ambient operating temperature (standard model)
- Low profile (<3" height)
- Versatile ceiling/swivel, wall, flush, pole and pendant mounting options
- Wide and narrow optics for uniform illumination in control room and drill mast
- Four points of secondary retention
- 2,000 PSI high pressure hose rated
- High vibration resistance
- Emergency battery back-up (90 minutes) and surge protection options (up to 10 kV)^A
- DesignLights Consortium® Qualified (some models are not DLC qualified)^B
- 5 year fixture warranty

Standard materials:

- Housing – copper-free aluminum; Corro-free epoxy powder coat (optional)
- Lens – clear polycarbonate; diffused polycarbonate

Photometrics:

- Complete photometrics can be found at www.crouse-hinds.com/photometrics

Temperature performance data:

Ambient temp. °C	Min. temp. supply wire °C	Simultaneous rating		
		Class I, Div. 2	Class II, Div. 2	Class I, Div. 2; Class II, Div. 2
40	60	T6	T6	T6
55	75	T5	T5	T5
65	90	T5	T5	T5



Mounting (ordered separately):

Versatile mounting options:

- Flush back mount
- Swivel/ceiling back mount
- Offset ceiling mount
- Offset wall mount
- Pole mount
- Pendant mount

Easily retrofit to:

- Existing Pauluhn DuraPro and MagnaPro fluorescent light fixtures
- Rig-A-Lite and Snelson C1D2 fluorescent lighting fixtures

Certifications and compliances:

NEC:

- Class I, Division 2, Groups A, B, C, D
- Class I, Zone 2
- Class II, Division 2, Groups F, G
- Class III
- NEMA 4X, IP66
- Marine and wet locations

UL standards:

- UL844 – Electrical Fixture Hangers for Hazardous Locations
- UL1598 – Luminaire
- UL1598A – Luminaire for Installation on Marine Vessels
- UL924 – Emergency Lighting

CSA standard:

- C22.2 No. 137

Additional certifications:

- ABS design assessed

Electrical ratings:

	DLL2	DLL4
Lumen output	3,958	7,900
Frequency	50/60 Hz	50/60 Hz
Voltage	100-277 VAC, 108-250 VDC; 347-480 VAC	

Model	Voltage	Current (A)	Watts	Power factor	THD
DLL2/UNV1	100	0.33	32.5	0.92	<20%
DLL2/UNV34	347	0.10	32.2	0.92	<20%
DLL2/UNV34	480	0.07	34.5	0.92	<20%
DLL4/UNV1	100	0.63	63.4	0.92	<20%
DLL4/UNV1	277	0.23	62.5	0.92	<20%
DLL4/UNV34	347	0.18	61.4	0.92	<20%
DLL4/UNV34	480	0.13	63.9	0.92	<20%

Weights:

Model	Lbs.	Kg.
DLL2	12.50	5.70
DLL4	22.50	10.20

^A One year warranty.

^B Refer to www.designlights.org Qualified Products List under Family Models for full listing details. Not all models are approved for all application categories.

Pauluhn DLL LED luminaires

For land-based drilling

Cl. I, Div. 2, Groups A, B, C, D
Cl. I, Zone 2
Cl. II, Div. 2, Groups F, G
Cl. III

UL Listed
CSA Certified
Marine & Wet Locations
NEMA 4X; IP66

2L

2L

Designed for drilling. Pauluhn DLL linear LED luminaires are engineered to handle demanding conditions faced on land-based drilling rigs. The DLL stands up to high vibration, hose down, shock and impact, while delivering long life and high lumen performance for up to 20 years.

Custom optics:

- Standard wide (120°) beam spread for control room and indoor application maximizes illumination on wall panels
- Narrow (80°) beam spread option for high mast/derrick application avoids spillage and light loss

Comprehensive certification:

- Single model certified for use in Class I, Division 2 and Class II, Division 2 harsh and hazardous applications

Quick & easy installation:

- Easy access to drivers and wiring
- No custom brackets or hardware needed
- Seven mounting options available
- Easily retrofit to Pauluhn DuraPro and MagnaPro, Rig-A-Lite and Snelson



Slim profile:

- 2.7" fixture height (excluding mounting brackets)
- Perfect for mounting in confined or low height areas

Built to last:

- Ingress protection from hose down water or diesel fuel in harsh operational conditions – passed 2,000 PSI high pressure test
- Vibration-, impact- and shock-resistant – passed 5G, 3-axis vibration test
- 60,000 hour lifetime at 55°C ambient



Pauluhn DLL LED Luminaires

For land-based drilling

Cl. I, Div. 2, Groups A, B, C, D
Cl. I, Zone 2
Cl. II, Div. 2, Groups F, G
Cl. III

UL Listed
CSA Certified
Marine & Wet Locations
NEMA 4X; IP66

2L

2L

Ordering information:

Part number example

DLL4N/UNV1 S903 TF P EM1

DLL	4	N	/UNV1	S903	TF	P	EM1
Series	Optics	Length / lumens	Voltage	Lens	Options	Finish	Emergency back-up
DLL Pauluhn DLL linear LED luminaire	BLANK Wide (120°) N Narrow (80°)	4 4 ft. length, 7,900 lumens 2 2 ft. length, 3,958 lumens	/UNV1 100-277 VAC, 108-250 VDC /UNV34 347-480 VAC	S903 Clear polycarbonate S903D Diffused polycarbonate	TF Pull wire included in fixture	BLANK Natural aluminum P Painted (gray, epoxy) WH Painted (white, epoxy)	BLANK Standard model (no battery back-up) EM1Ⓞ Integrated emergency battery back-up EM Remote emergency kit

Accessories (ordered separately):

Description	Cat. #	Description	Cat. #
• Flush/back mount back plate.....	DP1057MTK <i>Compatible with DuraPro</i>	• Pendant mount kit.....	PEND HAZ KIT
• Ceiling/swivel mount.....	DP1050MTK <i>Compatible with DuraPro</i>	• Safety chain kit.....	SS KIT
• Ceiling/wall mount offset.....	DP1053MTK <i>Compatible with DuraPro</i>	• 1 amp driver replacement kit, 100-277 VAC for 4 ft. linear.....	VMVL/UNV1 80W 1A KIT
• Ceiling mount bracket and adapter kit.....	MP1054MTK KIT <i>Compatible with MagnaPro</i>	• 1 amp driver replacement kit, 347-480 VAC for 4 ft. linear.....	VMVL/UNV34 80W 1A KIT
• Offset wall mount.....	DP1052MTK <i>Compatible with DuraPro</i>	• 0.5 amp driver replacement kit, 100-277 VAC for 2 ft. linear.....	VMVL/UNV1 80W 0.5A KIT
• Pole mount kit, 1.25" conduit.....	PM KIT 1.25	• 0.5 amp driver replacement kit, 347-480 VAC for 2 ft. linear.....	VMVL/UNV34 80W 0.5A KIT
• Pole mount kit, 1.50" conduit.....	PM KIT 1.5		
• Pole mount kit, 2.00" conduit.....	PM KIT 2.0		

Dimensions and mounting options:

DLL4 dimensions: (1329,1) 52.33", (157,9) 6.22", (68,58) 2.70"

DLL2 dimensions: (719,6) 28.33", (68,58) 2.70"

Mounting options shown:

- Offset wall DP1052MTK
- Flush ceiling DP1057MTK
- Offset ceiling DP1053MTK
- Ceiling/swivel DP1050MTK
- Ceiling and adapter MP1054MTK KIT
- Pole mount PM KIT 1.25/1.5/2.0
- Pendant mount PEND HAZ KIT

Ⓞ One year warranty. Remote EM kit also available, 120-277 VAC only. Available with 4 ft. model only.

Pauluhn DLL LED luminaires

For land-based drilling

Cl. I, Div. 2, Groups A, B, C, D
Cl. I, Zone 2
Cl. II, Div. 2, Groups F, G
Cl. III

UL Listed
CSA Certified
Marine & Wet Locations
NEMA 4X; IP66

2L

Mounting options:

Ceiling/swivel mount DP1050MTK

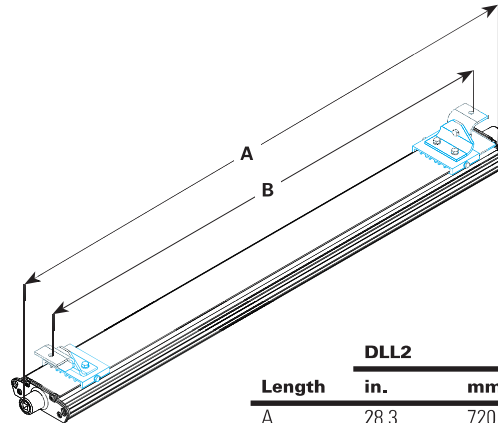
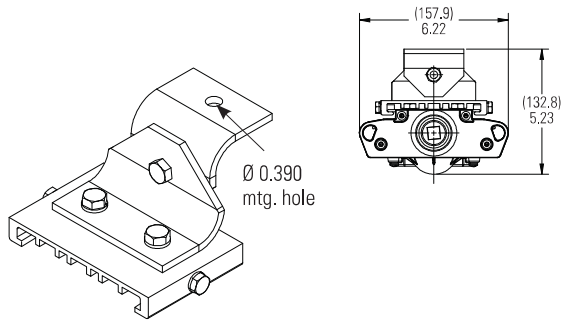

Length	DLL2		DLL4	
	in.	mm.	in.	mm.
A	28.3	720	52.3	1329
B	9-27	222-681	9-51	222-1289

Pole mount PM KIT 1.25/1.5/2.0

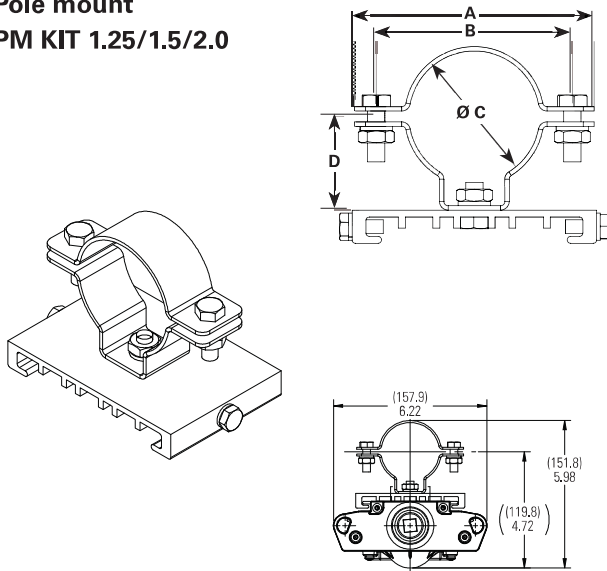

Configuration	ALL MEASUREMENTS IN INCHES			
	A	B	C	D
PM KIT 1.25	4.331	3.543	1.680	1.693
PM KIT 1.5	3.740	2.953	2.000	1.535
PM KIT 2.0	3.386	2.598	2.360	1.378

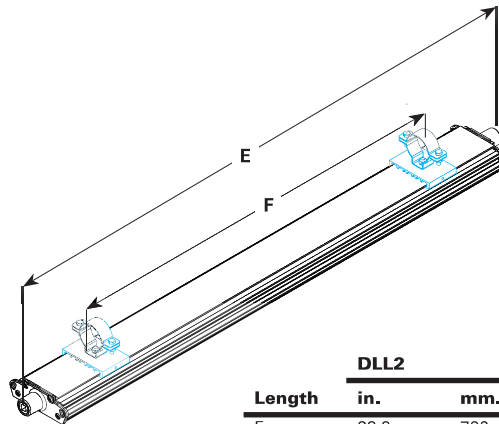

Length	DLL2		DLL4	
	in.	mm.	in.	mm.
E	28.3	720	52.3	1329
F	12-21	305-533	24-45	610-1143

MagnaPro mount MP1054MTK KIT

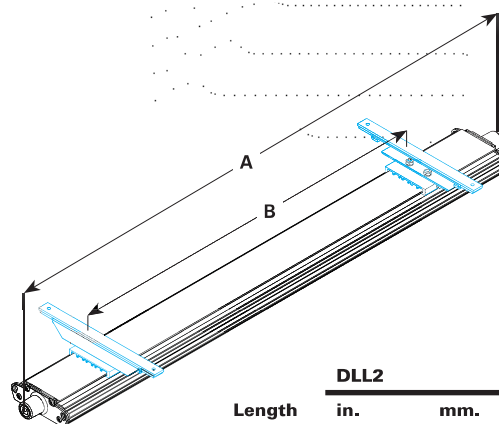
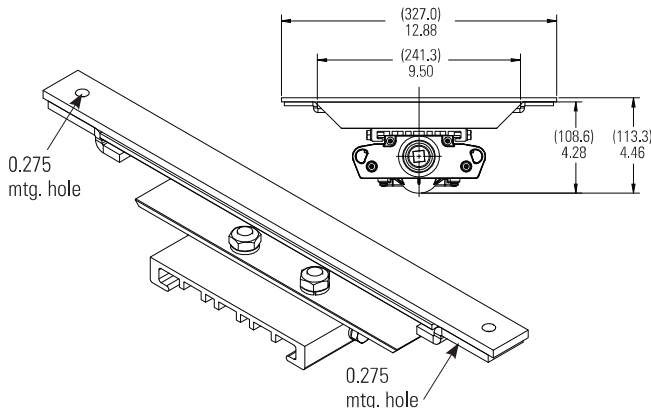

Length	DLL2		DLL4	
	in.	mm.	in.	mm.
A	28.3	720	52.3	1329
B	12-22	305-559	24-46	610-1168

Pauluhn DLL LED luminaires

For land-based drilling

Cl. I, Div. 2, Groups A, B, C, D
Cl. I, Zone 2
Cl. II, Div. 2, Groups F, G
Cl. III

UL Listed
CSA Certified
Marine & Wet Locations
NEMA 4X; IP66

2L

2L

Mounting options (continued):

Offset wall DP1052MTK

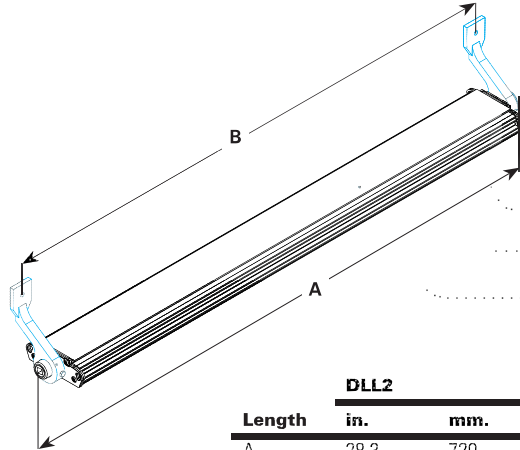
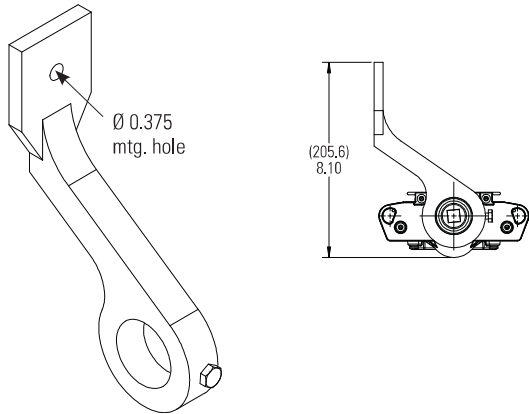

Length	DLL2		DLL4	
	in.	mm.	in.	mm.
A	28.3	720	52.3	1329
B	26.3	669	50.3	1278

Offset ceiling/wall mount DP1053MTK

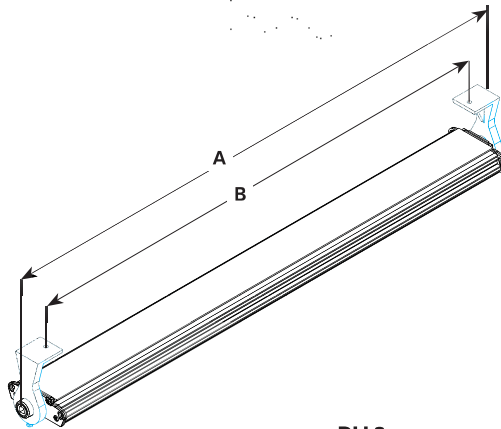
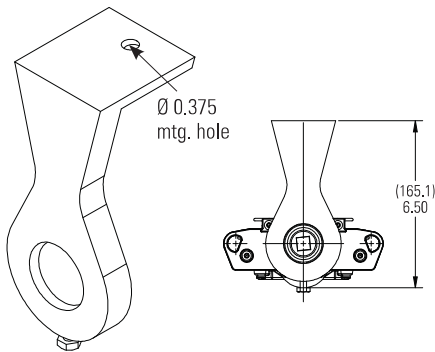

Length	DLL2		DLL4	
	in.	mm.	in.	mm.
A	28.3	720	52.3	1329
B	26.3	584	47.0	1194

Flush ceiling DP1057MTK

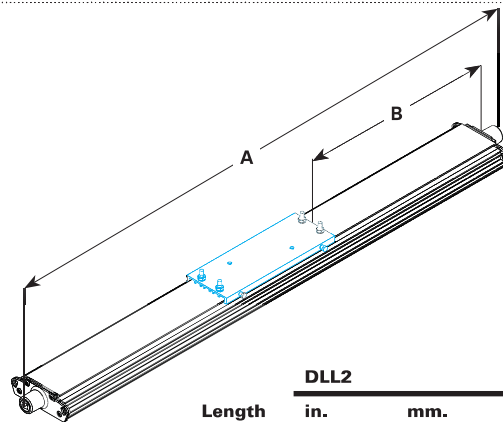
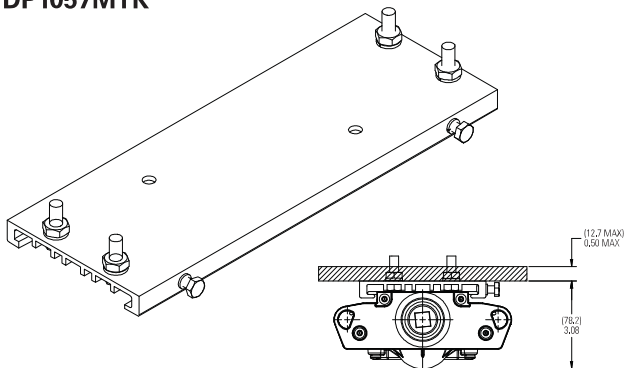

Length	DLL2		DLL4	
	in.	mm.	in.	mm.
A	28.3	720.0	52.3	1329.0
B	6.2	157.5	18.2	462.0

LUMINAIRE CLASSIFICATION SYSTEM (LCS) GRAPH

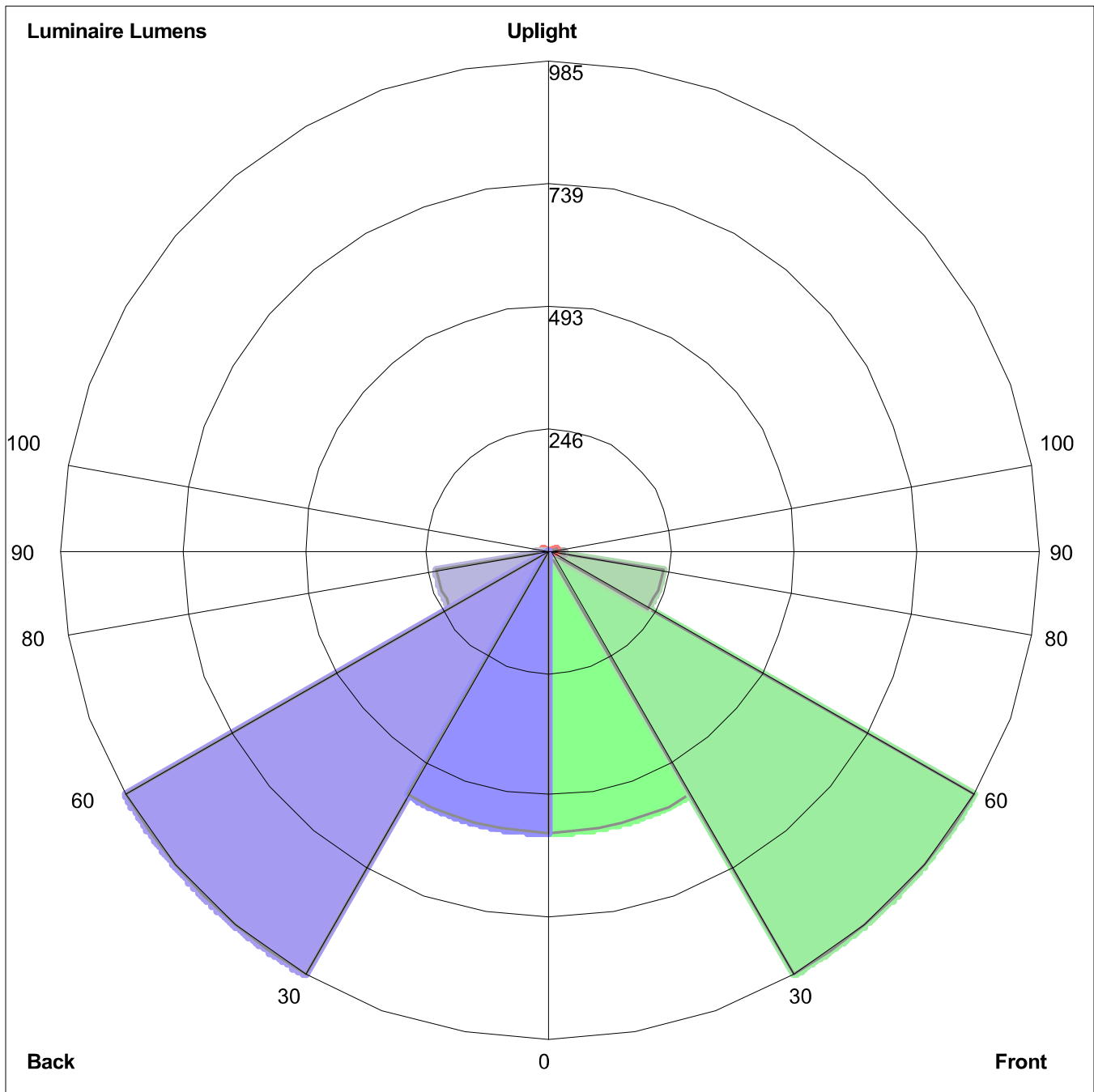

Luminaire Lumens:
Front: Low=568.6, Medium=985.4, High=230.6, Very High=28.4
Back: Low=568.6, Medium=985.4, High=230.6, Very High=28.4
Uplight: Low=12.8, High=0.3

BUG Rating : B2-U2-G1

FIXTURE CUT SHEET

TYPE G



Ultra high output, high efficiency LED floodlight with NEMA Types: 7H x 6V, 6H x 4V, 4H x 6V, 5H x 5V and 3H x 3V. patent-pending "Air-Flow" technology ensures long LED and driver lifespan. Use for general and security lighting for large areas, building façades, signs and landscapes.

Color: Bronze

Weight: 66.1 lbs

Project:

Type:

Prepared By:

Date:

Driver Info

Type	Constant Current
120V	2.65A
208V	1.59A
240V	1.38A
277V	1.17A
Input Watts	325.9W

LED Info

Watts	300W
Color Temp	5000K (Cool)
Color Accuracy	72 CRI
L70 Lifespan	100,000 Hours
Lumens	45,171
Efficacy	138.6 lm/W

Technical Specifications

Compliance

UL Listed:

Suitable for wet locations. Suitable for ground mounting.

IESNA LM-79 & LM-80 Testing:

RAB LED luminaires and LED components have been tested by an independent laboratory in accordance with IESNA LM-79 and LM-80.

DLC Listed:

This product is listed by Design Lights Consortium (DLC) as an ultra-efficient premium product that qualifies for the highest tier of rebates from DLC Member Utilities. DLC Product Code: PF5PMFXJ

Optical

NEMA Type:

NEMA Beam Spread of 7H x 6V

Performance

Lifespan:

100,000-Hour LED lifespan based on IES LM-80 results and TM-21 calculations

Construction

IP Rating:

Ingress Protection rating of IP66 for dust and water

Maximum Ambient Temperature:

Suitable for use in up to 40°C (104°F)

Effective Projected Area:

EPA = 4

Cold Weather Starting:

Minimum starting temperature is -40°C (-40°F)

Thermal Management:

Superior thermal management with external "Air-Flow" fins

Lens:

Tempered glass lens

Housing:

Die-cast aluminum housing and door frame

Mounting:

Heavy-duty slipfitter for 2 3/8"OD pipe

Reflector:

Specular and semi-specular vacuum-metalized polycarbonate

Technical Specifications (continued)

Construction

Gaskets:

High-temperature silicone gaskets

Finish:

Formulated for high durability and long-lasting color

Green Technology:

Mercury and UV free. RoHS-compliant components.

Tilt Increment:

Rotates in 6 degree increments

LED Characteristics

LEDs:

Multip-chip, high-output, long-life LEDs

Color Consistency:

7-step MacAdam Ellipse binning to achieve consistent fixture-to-fixture color

Color Stability:

LED color temperature is warranted to shift no more than 200K in color temperature over a 5-year period

Color Uniformity:

RAB's range of Correlated Color Temperature follows the guidelines of the American National Standard for Specifications for the Chromaticity of Solid State Lighting (SSL) Products, ANSI C78.377-2017.

Electrical

Drivers:

Constant Current, 1050mA, 50/60 Hz, 120-277V, 4 kV surge protection, 120V: 2.65A, 208V: 1.59A, 240V: 1.38A, 277V: 1.17A, THD <20%, Power Factor: 99%

THD:

9.26% at 120V, 12.56% at 277V

Power Factor:

99.3% at 120V, 96.6% at 277V

Note:

All values are typical (tolerance +/- 10%)

Other

Equivalency:

Equivalent to 1000W Metal Halide

Warranty:

RAB warrants that our LED products will be free from defects in materials and workmanship for a period of five (5) years from the date of delivery to the end user, including coverage of light output, color stability, driver performance and fixture finish. RAB's warranty is subject to all terms and conditions found at rablighting.com/warranty.

Buy American Act Compliance:

RAB values USA manufacturing! Upon request, RAB may be able to manufacture this product to be compliant with the Buy American Act (BAA). Please contact customer service to request a quote for the product to be made BAA compliant.

Dimensions

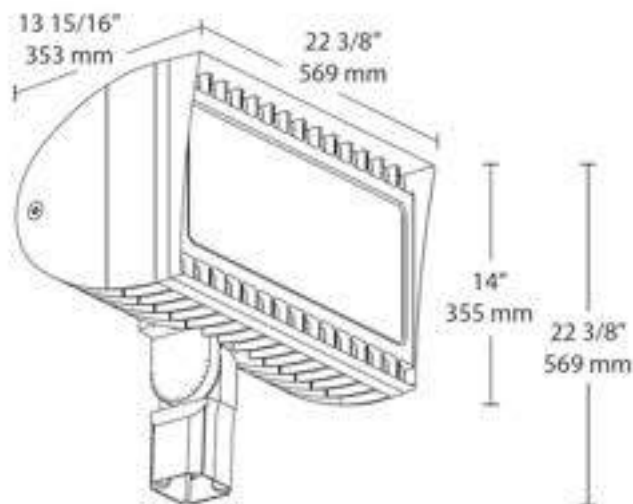

Features

- 300W replaces 1000 MH floodlights
- 100,000-hour LED lifespan
- 5-Year, No-Compromise Warranty

Ordering Matrix

Family	Wattage	Mounting	Color Temp	NEMA Type	Finish	Driver Options	Options	Other Options
FXLED	300	SF						
	200 = 200W 300 = 300W	SF = Slipfitter T = Trunnion	Blank = 5000K (Cool) N = 4000K (Neutral) Y = 3000K (Warm)	Blank = 7H x 6V B64 = 6H x 4V B55 = 5H x 5V B33 = 3H x 3V B46 = 4H x 6V	Blank = Bronze W = White	Blank = 120-277V /480 = 480V /BL = Bi-Level (Slipfitters only) ¹ /D10 = 0-10V Dimming	Blank = No option /PCS = 120V Swivel /PCS2 = 277V Swivel /PCT = 120-277V Twistlock /PCT4 = 480V Twistlock /PCS4 = 480V Swivel /LC = Lightcloud® Controller	USA = BAA Compliant Blank = Standard

¹ Slipfitter models only

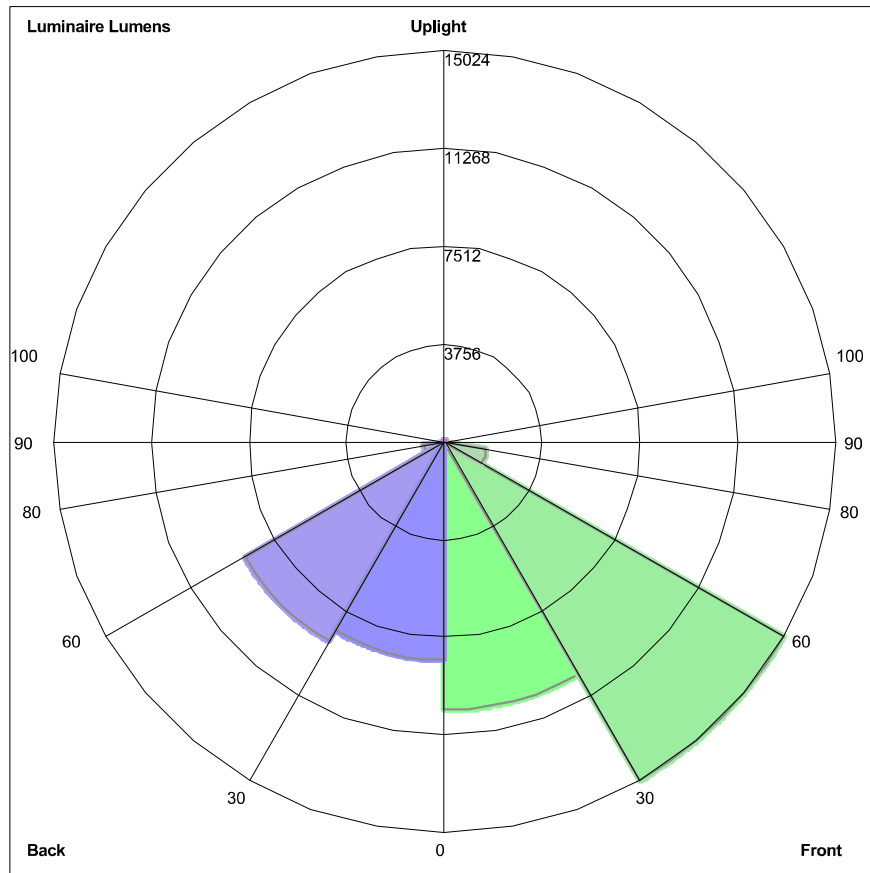

Luminaire Lumens:
 Front: Low=10319.6, Medium=15024.4, High=1636.8, Very High=9.1
 Back: Low= 8373.0, Medium=8865.3, High=802.5, Very High=9.9
 Uplight: Low=0.9, High=61.0

BUG Rating : B5-U3-G2

FIXTURE CUT SHEET

TYPE H



PHOENIX[®]
DURABILITY X DESIGN™



Cube-Light

Compact LED Area Light

Australian Design No. 359170
US Patent No. D762,321 S

Delivers up to 1000 lumens to doorways, walkways, cabins or other small areas

Competitive pricing with short lead times

Various mounting options for maximum versatility

LED technology increases efficiency, eliminates maintenance and supports green initiatives

Dimensions

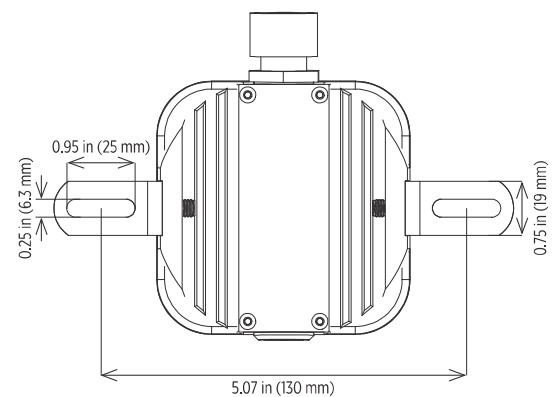
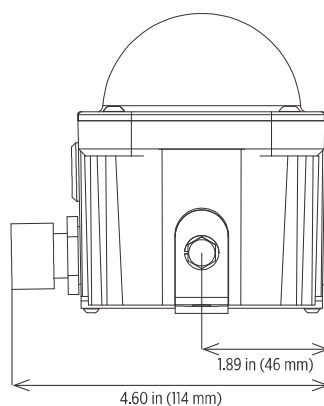
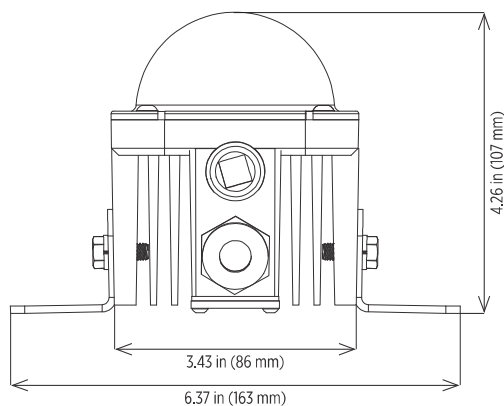

Cube-Light

Compact LED Area Light

Specifications

Construction	Cast aluminum housing
Finish	White thermoset powder coat
Hardware	Marine grade (316) stainless steel
Lens	Impact-resistant, diffuse polycarbonate Diffuse red, green, blue and amber lens accessories available (AMB-CL, BLU-CL, GRN-CL, RED-CL)
Light source	13W, up to 1000 lumens Conformal coated CRI ≥ 70 CCT 5000K 50,000 hour rated life
Power source	120-240V, 50/60Hz 240V, 50/60Hz 13-27V DC
Wiring	Stranded wires Cord not included - standard 72.00 inch (1829 mm) cord with pigtail option (CD) NEMA 5-15 plug (120V only) sold separately (PLG-515)
Through wiring	Continuous row mounting option (TW)
Ambient operating temperature	-30°C to +50°C
Mounting	Flush mount brackets - standard Harp mount available Rail mount available - 2.00 inch overall diameter Fixture can be mounted in any orientation
Weight	2.0 lb (0.9 kg)
Warranty	3 years

For IES files, see website or contact factory

Compliances

ETL/cETL Listed to:

- UL 1598 Suitable for Wet Locations
- UL 1598A Marine Outside Type (Saltwater)
- CSA C22.2 No. 250.0

CE

ABS

IP66 rated

LM79 and LM80 reports available



The Cube-Light on an STS crane



Ordering Information

Example: CL-13LED-120-240

Fixture	Wattage/Type	Voltage	Options
CL	13LED	120-240 ^{1,2} 240 ² DC ³	CD TW

Wattage/Type	Voltage	Options	Notes
13LED 13W, up to 1000 lumens	120-240 ^{1,2} 120-240V, 50/60Hz 240 ² 240V, 50/60Hz DC ³ 13-27V DC	CD 72.00 inch (1829 mm) cord with pigtail option TW Continuous row mounting	1 ETL/cETL listed 2 CE 3 No certifications

Special Projects: We may be able to accommodate your special projects, so please don't hesitate to ask about additional options. Minimum order quantities and/or extended lead times will apply. Contact your Phoenix representative with specific inquiries.

Mounting (order separately)

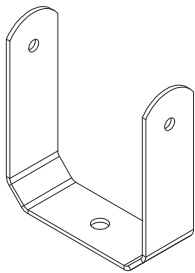

Harp Mount
HRP-CL

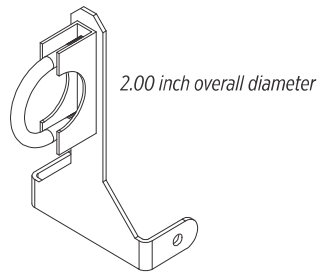

Rail Mount
RLMT-CL
Contact factory

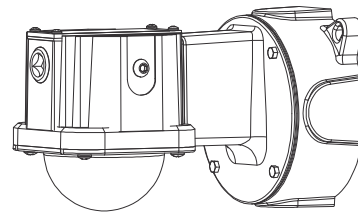

Wall Mount
Complete fixture sold separately
Refer to Cube-Light Wall Mount spec sheet

Flush mount comes standard with fixture

Accessories (order separately)

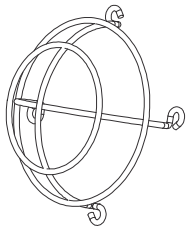

Wire Guard Kit
WG-CL

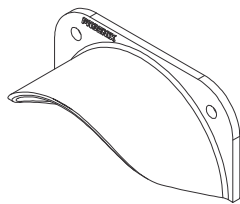

Visor Kit
VSR-CL

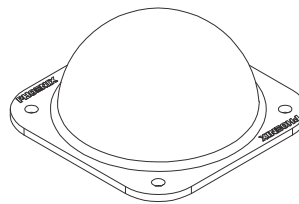

Color Lens Kits
AMB-CL amber lens kit
BLU-CL blue lens kit
GRN-CL green lens kit
RED-CL red lens kit

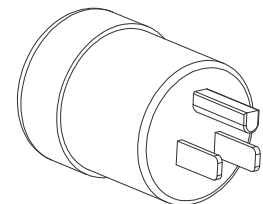

NEMA 5-15 plug (120V only)
PLG-515



LUMINAIRE CLASSIFICATION SYSTEM (LCS) GRAPH

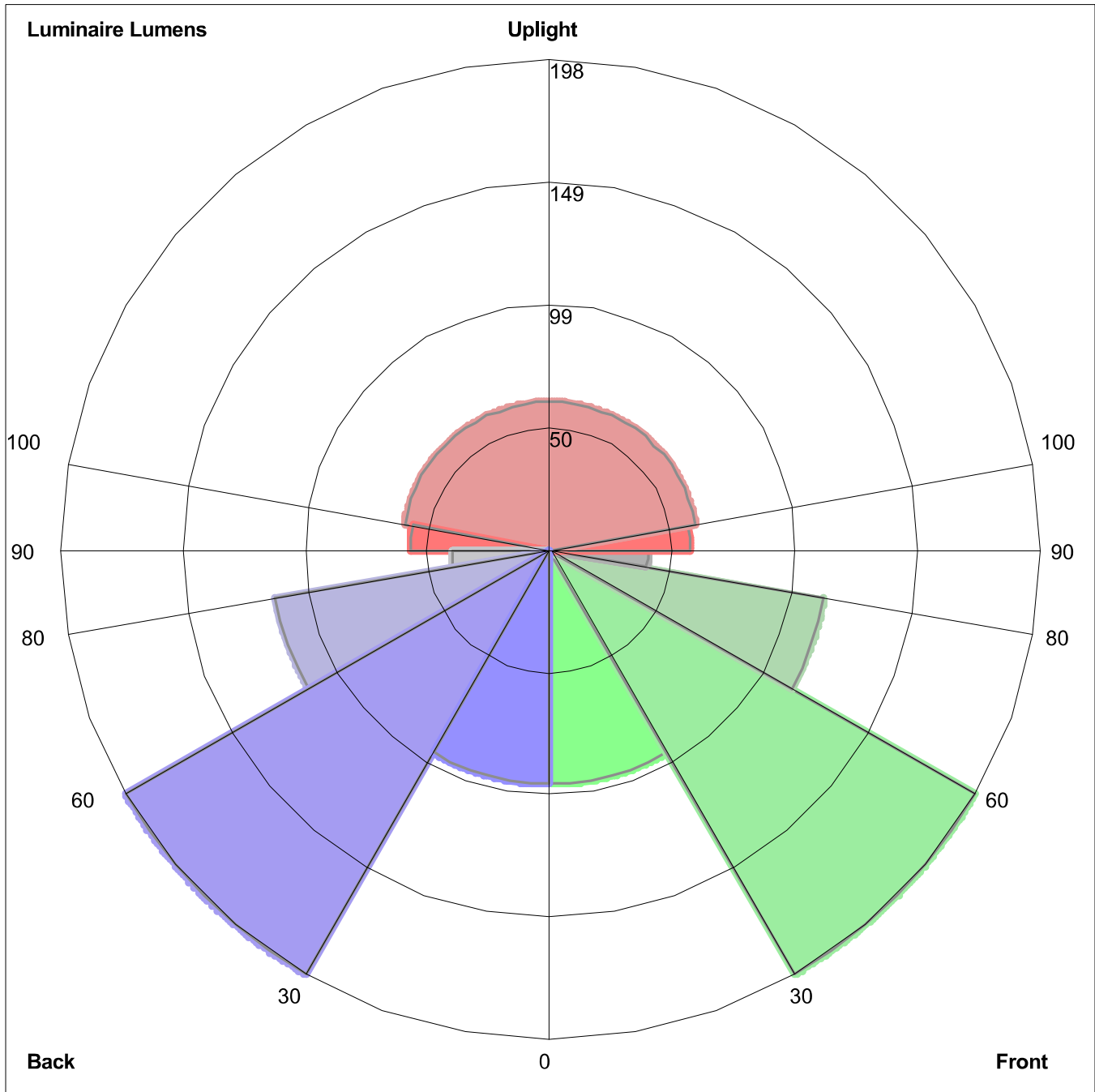

Luminaire Lumens:
Front: Low=94.7, Medium=198.1, High=112.5, Very High=39.7
Back: Low=94.7, Medium=198.1, High=112.5, Very High=39.7
Uplight: Low=56.4, High=59.7

BUG Rating : B1-U3-G1

FIXTURE CUT SHEET

TYPE I



Mounting: Vertical Green LED Heat Trace End Seal Kit

Part Number: E-100-L-A

Manufacturer: Raychem

Wattage: 2 watts at 60 Lumens/watt LED. 120 Lumens per end seal

APPROVALS

E-100-E	E-100-L-E
PTB 09 ATEX 1060 U Ⓜ II 2G Ex e II II 2D Ex tD A21 IP66 IECEX PTB 09.0038U Ex e II Ex tD A21 IP66 Ⓜ Ex e II T* <small>WIS</small>	Sira 14ATEX3015X Ⓜ II 2GD Ex e mb IIC T* Gb Ex tb IIIC T***°C Db Ta = -40°C to +40°C IECEX SIR 14.0007X Ex e mb IIC T* Gb Ex tb IIIC T***°C Db Ta = -40°C to +40°C Ⓜ CLI, ZN1, AEx e mb IIC T* Gb (1) ZN21 AEx tb IIIC T* Ⓜ Ex e mb IIC T* Gb <small>WIS</small> Ex tb IIIC T***°C Db
DNV Certificate No. E-11564 and E-11565 *For T-rating, see heating cable or design documentation (1) Except VPL	
EAC Ex TC RU C-BE.MI062.B.00054/18 Ex e IIC Gb U Ex tb IIIC Db U Ex e mb IIC Gb U Ex tb mb IIIC Db U Ta -55°C...+56°C IP66 000 "ТехИмпорт"	EAC Ex TC RU C-BE.MI062.B.00054/18 Ex e IIC Gb U Ex tb IIIC Db U Ex e mb IIC Gb U Ex tb mb IIIC Db U Ta -55°C...+56°C IP66 000 "ТехИмпорт"

PRODUCT SPECIFICATIONS

	E-100-E	E-100-L-E
Max. pipe temperature	Refer to heating cable specification (absolute maximum is 260°C)	
Max. operating voltage	480 V*	277 V
	*Extra conditions for safe use apply for voltages above 277 V. Please refer to the certificate or installation instructions for full details.	
Ambient temperature range	-50°C to +56°C*	-40°C to +40°C
	*Extra conditions for safe use apply for ambient temperatures above +40°C. Please refer to the summary the certificate or installation instructions for full details.	
Min. installation temperature	-50°C	-40°C
Overall height	171 mm	197 mm
Outer diameter	46 mm Usable with up to 100 mm thermal insulation	66 mm
Ingress protection	IP66, Type 4X	IP66, Type 4X
Impact resistance	EN 60079-30-1, ≥ 7 joules	EN 60079-30-1, ≥ 7 joules
UV stability	No degradation after > 1000 h	No degradation after > 1000 h
Solvent resistance	Excellent	Excellent
Strain relief	> 250 N	> 250 N

LIGHT SOURCE

Type	Green LEDs
Voltage rating range	110-277 Vac, 50/60 Hz
Power consumption	< 2 W
Electromagnetic immunity/emissions	Complies with IEC61000-6 and IEC61000-4

INSTALLATION DATA

Tools required	Cable knife, wire cutters, screwdriver	Cable knife, wire cutters, screwdriver, crimp tool (Panduit-CT-100), long nose pliers
----------------	--	---

ORDERING DETAILS

End seal

Part description	E-100-E	E-100-L-E
PN (Weight)	101255-000 (0.22 kg) Requires one pipe strap (not supplied)	P000001583 (0.63 kg) Requires one pipe strap (not supplied) PTB, DNV and EAC approved product

ACCESSORIES

Small pipe adaptor JBS- SPA, required for pipes $\leq 1"$ (DN 25), E 90515-000 (bag of 5 adaptors)

SPARE PART

Boot pack for E-100-E

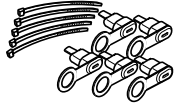

Part description	E-100-BOOT-5-PACK
PN (Weight)	281053-000 (140 g)
Pack size	5 sealant filled boots and 5 cable ties

Replacement indicator light for E-100-L

Part description:	E-100-LR-E
PN	P000001586

North America

Tel +1.800.545.6258
Fax +1.800.527.5703
thermal.info@nVent.com

Europe, Middle East, Africa

Tel +32.16.213.502
Fax +32.16.213.604
thermal.info@nVent.com

Asia Pacific

Tel +86.21.2412.1688
Fax +86.21.5426.3167
cn.thermal.info@nVent.com

Latin America

Tel +1.713.868.4800
Fax +1.713.868.2333
thermal.info@nVent.com



Our powerful portfolio of brands:

nVent.com

CADDY

ERICO

HOFFMAN

RAYCHEM

SCHROFF

TRACER

LUMINAIRE CLASSIFICATION SYSTEM (LCS) GRAPH

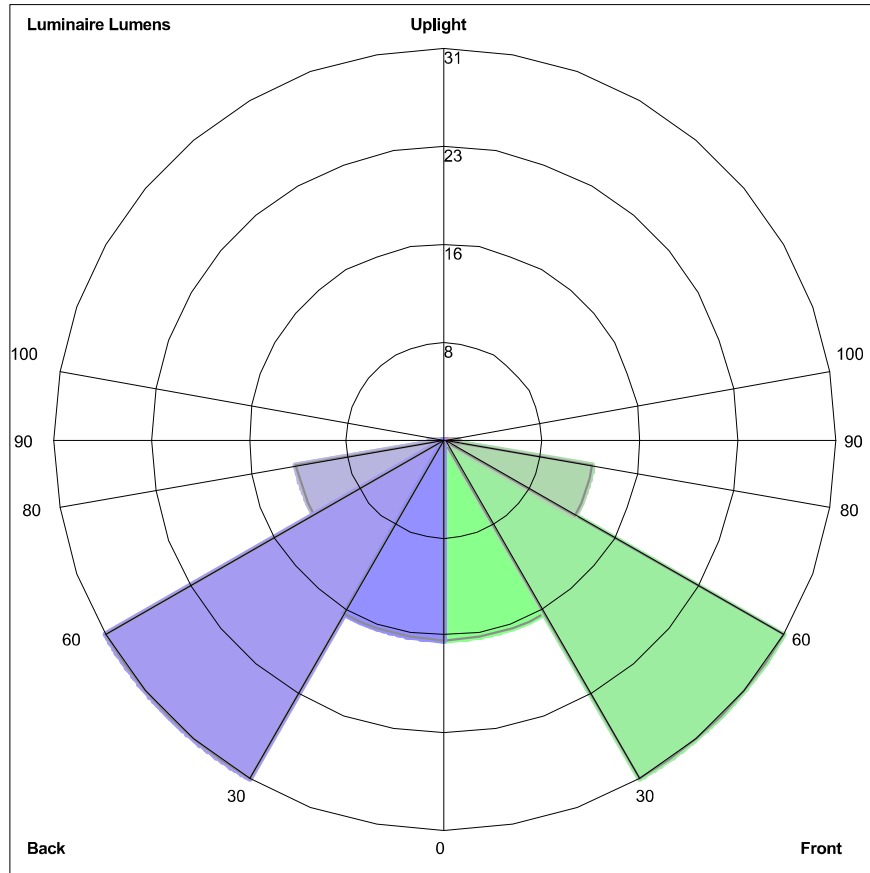

Luminaire Lumens:
Front: Low=16.0, Medium=31.2, High=12.0, Very High=1.2
Back: Low=16.0, Medium=31.2, High=12.0, Very High=1.2
Uplight: Low=0.0, High=0.0

BUG Rating : B0-U0-G0

FIXTURE CUT SHEET

TYPE J

Note:

Eaton general FMV9L Floodlight IES file used for generation of Roadway LCS graph which represents a smaller unit with the same lumen output. Eaton IES file provided for FMVA9LWYUNV176-S891 does not include data above 90 degrees vertical and therefore a LCS graph can not be created.

Champ FMVA LED floodlights

Cl. I, Div. 2, Groups A, B, C, D
Cl. I, Zone 2
Cl. II, Groups E, F, G

UL Listed
IECEX/ATEX
Type 4X; IP66

6L

The Champ FMVA LED family

Champ® FMVA LED floodlights are designed to provide full-spectrum, crisp, white light. Seven versions of the FMVA LED are available, from 3,000 to 15,000 lumens, providing ideal solutions for a wide range of harsh and hazardous applications.

Model	Nominal lumens ^A	Watts	Lumens per watt	Equivalent HID luminaire	Energy savings
FMVA3L	3,312	26	129	70W	Up to 75% reduction in energy costs and 150,000 hours of continuous operation
FMVA5L	5,381	40	133	100W	
FMVA7L	7,274	55	132	175W	
FMVA9L	9,429	67	142	250W	
FMVA11L	11,776	82	144	320W	
FMVA13L	13,362	93	143	400W	
FMVA15L	15,183	108	140	500W	



Applications:

- Oil and gas refineries, drilling rigs, petrochemical facilities, food and beverage facilities, platforms, loading docks, tunnels, outdoor wall and stanchion mounted general area lighting, and where flammable vapors, gases, ignitable dusts, fibers or flyings are present
- Locations requiring continuous and consistent light levels in extreme ambient temperatures
- Where extremely corrosive, wet, dusty, hot and/or cold conditions exist
- IP66, Type 4X, marine, wet locations and hose down environments
- Classified and hazardous locations

Features:

- Instant illumination and restrike
- Better visibility with crisp, white light
- Cold temperature operation/no warm-up required
- Minimum T3C temperature rating – safely operate in the most hazardous environments and any non-hazardous location
- Serviceable drivers
- Easy installation – yoke design to mount to SFA6
- Energy-efficient technology – up to 72% energy savings over HID fixtures
- 60,000 hours of rated life at 55°C – eliminates need for frequent lamp replacement
- Contains no mercury or other hazardous substances
- Shock- and vibration-resistant solid state luminaires have no filaments or glass components that could break – greatly reduces the risk of premature failure
- Operating ambient: -40°C to 65°C (NEC only); IEC: -40°C to 55°C)
- 5 year fixture warranty

Certifications and compliances:

- DesignLights Consortium® Qualified (pending)^B
- NEC/CEC:
 - Class I, Division 2, Groups A, B, C, D; Class I, Zone 2; Class II, Groups E, F, G
 - Wet locations, Type 4X, IP66

UL standards:

- UL844; UL1598; UL1598A; UL8750

IEC standards^C:

- IEC 60079-0, 6th Edition (2011-06) + Corr. 1 (2012-01) + Corr. 2 (2013-12) + I-SH 01 (2013-11) + I-SH 02 (2014-10)/EN 60079-0:2012 + A11:2013
- IEC 60079-7, Edition 5.1 (2017-08)/EN 60079-7: 2015 +A1:2018
- IEC 60079-31, 2nd Edition (2013-11)/EN 60079-31:2014
- IEC 60598-1:2008/EN60598-1:2008
- IEC 60598-2:2008/EN60598-2:2008

IECEX/ATEX^D:

- CE 0359
- IECEX UL15.0029X
- DEMKO 15 ATEX 1377X
- DEMKO 15 ATEX 1383
- Ex II 3 G Ex ec mb IIC T5 Gc Tamb -40° - +40°C
- Ex II 3 G Ex ec mb IIC T5 Gc Tamb -40° - +40°C^E
- Ex ec IIC T5 Gc Tamb -40°C - +40°C
- Ex ec IIC T4 Gc Tamb -40°C - +55°C
- Ex II 2 D Ex tb IIIC T65 Db Tamb -40°C - +40°C
- Ex II 2 D Ex tb IIIC T80 Db Tamb -40°C - +55°C
- Ex tb IIIC T65 Db Tamb -40°C - +40°C
- Ex tb IIIC T80 Db Tamb -40°C - +55°C

Standard materials:

- Lamp housing and adapter – die cast aluminum with Corro-free epoxy powder coat
- Lens – heat- and impact-resistant glass (standard)
- Gaskets – silicone and neoprene
- External hardware – stainless steel

Fixture life:

- Rated life of 60,000 hours at 55°C operating ambient and 24/7 continuous operation for 365 days
- Economic life of 150,000 hours at 25°C ambient

LED system:

- Cool white (5000K, 70 CRI) and warm white (3000K, 80 CRI)
- Custom designed optics – 7x6 standard; 3x3 (optional)

Photometrics:

- Complete photometrics can be found at www.crouse-hinds.com/photometrics

Electrical ratings:

Model	Input power (watts)	Input amps at 120-277 VAC
FMVA3L	25	0.27 - 0.10
FMVA5L	40	0.41 - 0.16
FMVA7L	54-56	0.56 - 0.21
FMVA9L	67-69	0.78 - 0.28
FMVA11L	81-84	0.84 - 0.30
FMVA13L	91-95	0.95 - 0.34
FMVA15L	107-113	1.12 - 0.40

FMVA3L-FMVA15L

Voltage range, VAC ^G	100-277V at 50/60 Hz
Voltage range, VDC	127-250V
Power factor	>0.90 ^H

^ATolerance +/- 10%; at 120 VAC, 25°C ambient, 7x6 optics.

^BRefer to www.designlights.org Qualified Products List under family models for full listing details. Not all models are approved for all application categories.

^CIEC voltage; 100-250 VAC at 50/60 Hz, UNV34 option for FMVA9L-15L only.

^DFor FMVA3L: PF >0.90 from 100-255 VAC. From 255-277V, it varies +/- 10%. All other lumen levels are above 0.90 PF across full voltage range.

^ET4 from -40°C to +40°C when used with 3x3 optic.

^HNot applicable for FMVA9L-15L UNV34.

Champ FMVA LED floodlights

Cl. I, Div. 2, Groups A, B, C, D
Cl. I, Zone 2
Cl. II, Groups E, F, G

UL Listed
IECEX/ATEX
Type 4X; IP66

6L

Versatile design

- Can be used for outdoor or indoor applications, and for a wide range of mounting heights depending on model and light level requirement

Smaller and lighter

- 25% smaller footprint than previous model
- 10 lbs. (4.5 kg) less weight than previous model

Full-frame yoke

- Designed to utilize the SFA6 slipfitter and SWB6 wall mount bracket, making it ideal for retrofit or new installations



High lumen output

- Up to 144 lumens per watt
- Up to 72% energy savings over traditional HID fixtures (compared to 400W MH)



Multiple lens options

- Tempered clear glass lens standard
- Polycarbonate and diffused glass lens options available

Rugged heat sink

- Heat sink designed to perform and provide maximum light levels in high ambient temperatures up to +65°C and as low as -40°C
- Thick walled castings make for a tough, rugged housing that keeps the internal driver and LED temperature down



Champ FMVA LED floodlights

Cl. I, Div. 2, Groups A, B, C, D
Cl. I, Zone 2
Cl. II, Groups E, F, G

UL Listed
IECEX/ATEX
Type 4X; IP66

6L

Ordering information:

Part number example

FMVA7LCY-UNV1-76-M20-S891-BZ

FMVA 7L C Y - UNV1 - 76 - M20 - S891 - BZ

Light source / intensity	
3L	3,312 nominal lumens [Ⓔ]
5L	5,381 nominal lumens [Ⓔ]
7L	7,274 nominal lumens [Ⓔ]
9L	9,479 nominal lumens [Ⓔ]
11L	11,776 nominal lumens [Ⓔ]
13L	13,362 nominal lumens [Ⓔ]
15L	15,183 nominal lumens [Ⓔ]

Color temperature	
C	5000K, 70 CRI (cool white)
W	3000K, 80 CRI (warm white)

Mounting	
Y	Yoke

Voltage	
/UNV1 [Ⓕ]	100-277 VAC, 50/60 Hz; 127-250 VDC
/UNV34 [Ⓖ]	347-480 VAC, 50/60 Hz

Optical distribution	
76	7x6 floodlight pattern optics
33	3x3 floodlight pattern optics

Entries	
BLANK	3/4" NPT
M20	20mm
M25	25mm

Paint	
BLANK	Gray
BZ	Bronze
WH	White

Lens material	
BLANK	Clear glass lens
S891	Diffused glass lens
S903	Polycarbonate lens

Options:

Description	Suffix
• Diffused glass lens	S891
• Polycarbonate lens	S903

Accessories (ordered separately):

Description	Cat. #
• Bull horn, gray.....	BLHN
• Bull horn, bronze.....	BLHN-BZ
• Bull horn, white	BLHN-WH
• Bolt-on visor.....	DSV2
• Bolt-on wire guard	P62
• 316 stainless steel safety cable	SC831
<i>Can be added in the field</i>	
• Floodlight slipfitter	SFA6
• Slipfitter wall mount adapter	SWB6

Replacement driver kits (ordered separately)

FMVA 3-5-7L UNV1 DRIVER KIT	UNV1 Replacement driver kit for 3L, 5L and 7L models
FMVA 9-11-13L UNV1 DRIVER KIT	UNV1 Replacement driver kit for 9L, 11L and 13L models
FMVA 15L UNV1 DRIVER KIT	UNV1 Replacement driver kit for 15L model
FMVA 9L-11L UNV34 DRIVER KIT	UNV34 Replacement driver kit for 9L and 11L models
FMVA 13L-15L UNV34 DRIVER KIT	UNV34 Replacement driver kit for 13L and 15L models

[Ⓔ] 7x6 model.

[Ⓕ] IEC voltage; 100-250V at 50/60 Hz.

[Ⓖ] Available for FMVA9L-15L only.

LUMINAIRE CLASSIFICATION SYSTEM (LCS) GRAPH

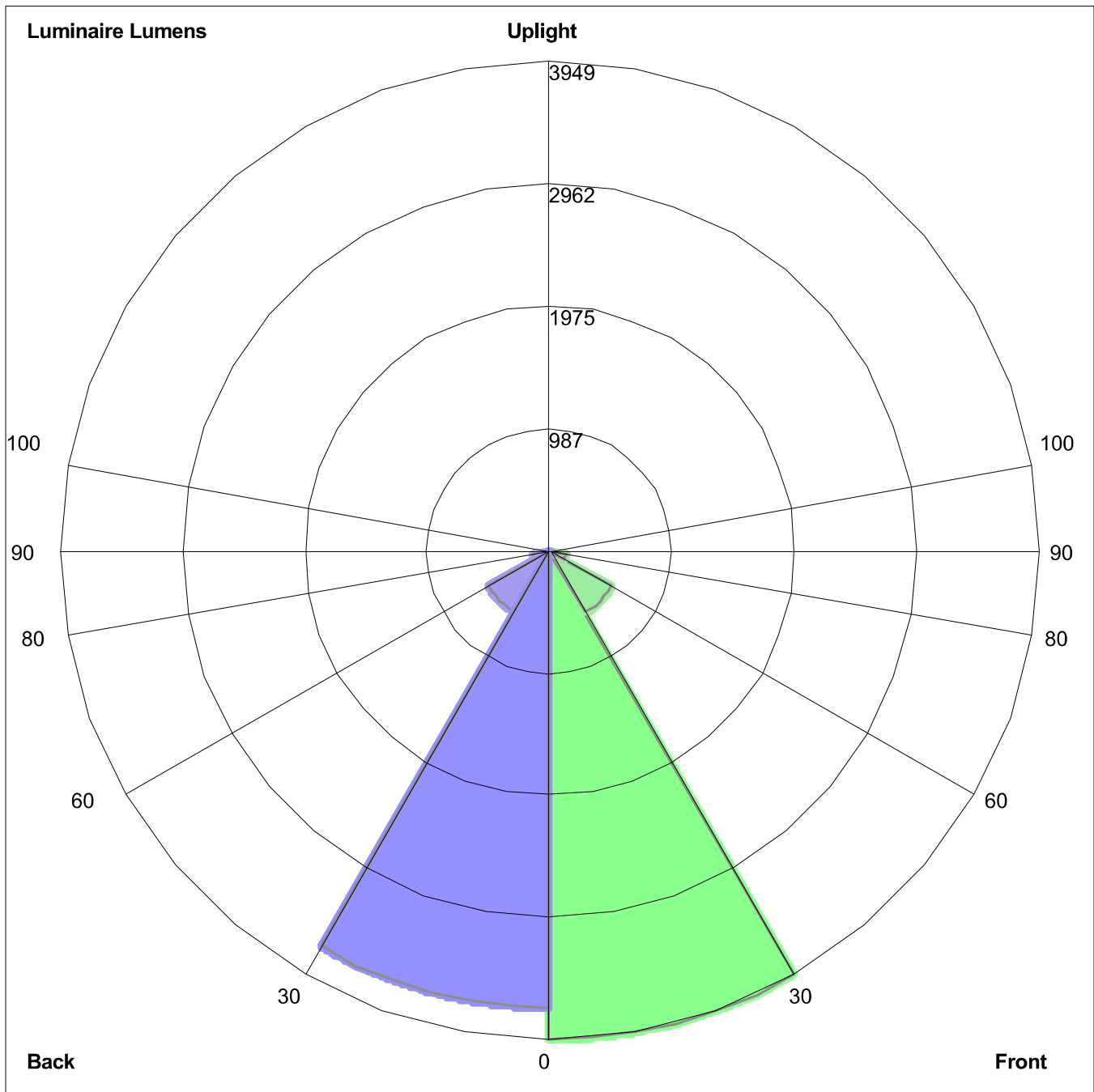

Luminaire Lumens:
Front: Low=3949.3, Medium=578.7, High=135.5, Very High=4.8
Back: Low=3692.4, Medium=570.4, High=132.6, Very High=4.7
Uplight: Low=0.0, High=0.0

BUG Rating : B4-U0-G0

FIXTURE CUT SHEET

TYPE K

Design features



Shown with optional diffused lens

Built to last:

- Type 4X rated
- Impact-resistant lens sealed from the outside environment provides ingress protection against water and dust
- Die cast aluminum LED housing provides efficient thermal path to heat sink assembly
- Vertical fin design facilitates air flow and dust shedding

Simple installation and replacement:

- Contractor-friendly design is ideal for both retrofit and new construction
- Easy to retrofit using existing HID Champ mounting module
- Available with lever lock connectors and standard three-pole terminal block

Custom optics:

- Type I, III and V optics designed to maximize light distribution and intensity*
- * Type V optics standard.

Increased efficiency:

- Up to 127 lumens per watt (7L model)



Multiple lens options:

- Clear glass lens standard
- Uplight refractor lens provides ~5% uplight and ~16% sidelight for better visibility
- Optional lenses include diffused glass, clear polycarbonate or upright refractor

Shown with optional upright refractor lens and guard

Connected lighting

Flexible & intuitive software controls

Tune light output to meet safety and task needs – light where you need it

For more information go to:
Crouse-Hinds.com/LEDconnected



Why choose Champ VMVL?

Safe, reliable and efficient. VMVL LED luminaires are engineered to deliver high lumen output and maintenance-free long life in the toughest conditions.

VMVL-7 vs. 175 watt HID



77%
ENERGY
EFFICIENCY

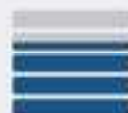

75%
TOTAL COST
OF OWNERSHIP

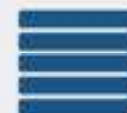

100%
MAINTENANCE
REDUCTION

Assumptions: Calculations based on overall life of the LED system. Energy cost of \$0.09 per kilowatt, 24-hour per day operation; labor rate of \$75 each for 2 workers; average time for fixture maintenance of 1 hour.

Rugged solutions for complex environments.

Champ VMVL LED luminaires are engineered to provide maintenance-free illumination in the most demanding hazardous rated environments.

The Champ VMVL features a compact, high efficacy design with custom optics to ensure maximum efficiency and mounting flexibility, including the ability to retrofit the Crouse-Hinds installed base to service both LED upgrades and new projects.

Model	Nominal lumens*	Watts	Efficacy	Equivalent HID
VMVL-3	3,250	26	123 lm/W	70W
VMVL-5	5,537	43	127 lm/W	100W
VMVL-7	7,442	59	127 lm/W	175W
VMVL-9	9,234	73	126 lm/W	250W
VMVL-11	11,114	91	122 lm/W	320W
VMVL-13	13,100	105	125 lm/W	400W

*Nominal lumens based on Type V optics, 5000K CCT with clear glass lens.
Wattage measured at 120VAC.

Applications:

- For areas with mounting heights of up to 30 feet
- Oil and gas refineries, drilling rigs, petrochemical facilities, food and beverage facilities, platforms, loading docks, tunnels, indoor/outdoor spotlighting, outdoor wall and stanchion mounted general area lighting, and where flammable vapors, gases, ignitable dusts, fibers or flyings are present
- Locations requiring continuous and consistent light levels in extreme ambient temperatures
- Extremely corrosive, wet, dusty, hot and/or cold conditions
- Classified and hazardous locations

Champ VMVL benefits:

- Instant illumination and restrike
- Cold temperature operation / no warm-up required
- Option for redundancy in drivers with multiple series circuits connected to each driver to avoid complete loss of illumination
- Easy installation - compact modular fixture attaches onto existing Champ mounting module
- Energy-efficient technology - up to 77% energy savings over HID fixtures
- Contains no mercury or other hazardous substances
- Shock- and vibration-resistant solid-state luminaires have no filaments or glass components that could break - greatly reduces the risk of premature failure
- Operating ambient: -40°C to 65°C
- Up to 60,000 hours lifetime at 55°C
- 5 year fixture warranty†

†Refer to page 2 of the authorized distributor price book for Crouse-Hinds standard Terms and Conditions.

LED system:

- High intensity discrete power emitters
- Standard: cool white (5000K, 70 CRI); optional: warm white, (3000K, 80 CRI) or neutral white (4000K, 70 CRI)
- Custom Type I, III and V optics available

Colored LED options:

- Available in green or amber*
- Reduction in light pollution for night space observation and sky glow due to isolating blue wavelength in red and amber colors
- Wildlife-friendly
- Improves visibility for telescopes in observatories during night sky space exploration

*Custom optics not available with colored LEDs.

Connected lighting

Remote monitoring and control for use in hazardous and hard-to-access areas.



Connected lighting highlights:



Advanced scheduling control allows for improving energy efficiency during non-operational hours. Easy software control lets a user set up schedules for lights to be on and off at pre-defined times, removing the challenges of manual management.



Daylight harvesting allows for use of the daylight and adjusts the light level of luminaire to maintain the desired light levels. It is best suited for outdoor environments or indoor areas where daylight is present during operational hours of a facility.



Fixture grouping is an added benefit that maximizes control in a defined area. By grouping light fixtures, same control settings can be applied to them to increase efficiency and response time.



Occupancy sensing is best used in areas that see infrequent traffic, such as storage areas of warehouses. Innovative occupancy sensor controls can automatically illuminate the area once presence is sensed in an area and also turn it back off when sensors stop sensing the presence.



Advanced dimming controls help reduce the energy consumption by setting dimming levels. Dimming controls could be used in conjunction with other control features, such as scheduling and occupancy sensing, to improve energy savings.

Flexible & intuitive software controls

Tune light output to meet safety and task needs
- light where you need it



For more information go to:
Crouse-Hinds.com/LEDconnected

Certifications and compliances:

NEC, CEC & IEC

- Class I, Division 2, Groups A, B, C, D
- Class II, Groups E, F, G
- Class III
- Class I, Zone 2 AEx'ec mb IICT*GC
- Zone 21 tb IIIC
- Simultaneous Presence
- Wet Locations, Type 4X

UL standards

- UL 844 Hazardous (Classified)
- UL1598 Luminaires, UL1598A Marine

CSA standard

- CSA C22.2 No. 137

IEC/ATEX standards*

- IEC 60079-0:2011, 6th Edition / EN 60079-0:2012
- IEC 60079-7:2010, 5.1 Edition / EN 60079-7:2015
- IEC 60079-31:2008, 2nd Edition / EN 60079-31:2014
- IEC 60529:2001 / EN 60529:2001
- IEC 60598-1:2008 / EN 60598-1:2008
- IEC 60598-2:2008 / EN 60598-2:2008
- IEC 60079-18:2017, 4.1 Edition / EN 60079-18:2015 + A1:2017

*IEC/ATEX certifications applicable for voltage ranges: 100-277VAC, 127-250 VDC.

Luminaire markings

- IECEx UL 13.0052X
- DEMKO 13 ATEX 1305741X
- DEMKO 13 ATEX 1475031X

100-277 VAC/127-250 VDC (UNV1 luminaire only)

- Ⓜ II 3 G EX ec mb IICT5 Gc -40°C to +40°C
- Ⓜ II 3 G EX ec mb IICT5 Gc -40°C to +55°C
- Ⓜ II 3 G EX ec mb IICT4 Gc -40°C to +65°C
- Ⓜ II 2 D Ex tb IIIC T72°C Db -40°C to +40°C
- Ⓜ II 2 D Ex tb IIIC T87°C Db -40°C to +55°C
- Ⓜ II 2 D Ex tb IIIC T92°C Db -40°C to +65°C

Qualifications and compliances:

- DesignLights Consortium® Qualified (pending)*

*Refer to www.designlights.org Qualified Products List under family models for full listing details. Not all models are approved for all application categories.

Standard materials:

- Lamp housing and adapter - die cast aluminum with Corro-free™ epoxy powder coat
- Lens - heat- and impact-resistant glass
- Gaskets - silicone
- External hardware - stainless steel
- Factory-sealed, no external seals required

Weights:

Model	lbs.	kg.	Mounting module	lbs.	kg.
VMVL3 to VMVL7	19.00	8.62	Pendant	1.25	0.57
VMVL8 to VMVL12	19.20	8.70	Cone pendant	4.00	1.81
			Flexible pendant	1.50	0.68
			Ceiling	2.75	1.25
			Wall	4.50	2.04
			Angled stanchion	3.50	1.59
			Straight stanchion	4.50	2.04

Uplight refractor lens now available



Maximize light dispersion

The new uplight refractor lens is perfect for low bay ceilings, suspended pendant mounts, areas with elevated infrastructure or areas which require dispersed side and uplight illumination.

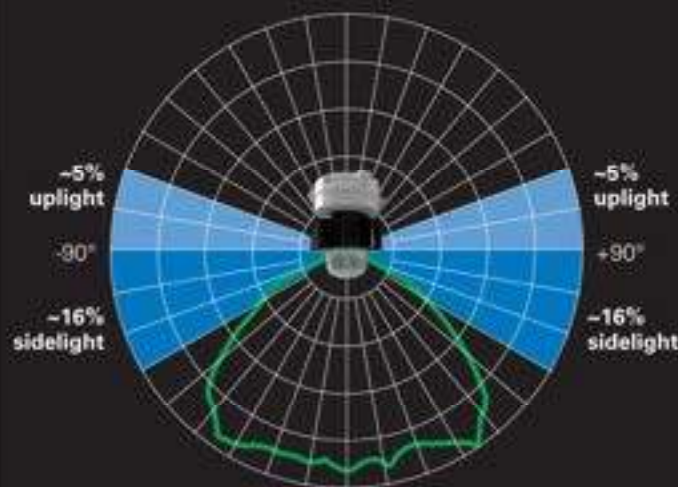

More directional light

~5% uplight and ~16% sidelight for better visibility



For more information go to:
Crouse-Hinds.com/ChampLED

Ordering information

Part number example: **VMVL-3-N-2A-R1-G-UNV1-S831-S891**

Champ VMVL, 3,000 lumens, 4000K neutral white, ¾" pendant mount, Type I optics, wire guard, 100-277 VAC driver, safety cable, diffused glass lens

VMVL - 3 - N - 2A - R1 - G - UNV1 - S831 - UPLT

Light source/intensity

3	3,250 nominal lumens
5	5,537 nominal lumens
7	7,442 nominal lumens
9	9,234 nominal lumens
11	11,114 nominal lumens
13*	13,100 nominal lumens
A	Amber - 5,200 lumens
G	Green - 4,300 lumens

*For 13L models, add "-M2" suffix at the end of the part number.
Example: VMVL-13-2A-R1-UNV1-S831-M2

Color temperature

BLANK	5000K, 70 CRI (cool white)
N*	4000K, 70 CRI (neutral white)
W	3000K, 80 CRI (warm white)

*Consult factory for lead time.
**5700K and 6500K are available upon request; consult factory.
***Not available for Amber or Green LED.

Mounting

BLANK	No mounting module
J	1-½" stanchion, 25° angled
P	1-½" stanchion, straight
2A	¾" pendant
3A	1" pendant
20A	20mm pendant

25A	25mm pendant
2B	¾" cone pendant
3B	1" cone pendant
2HA	¾" flexible pendant
2C	¾" ceiling
3C	1" ceiling

20C	20mm ceiling
25C	25mm ceiling
2TW	¾" wall
3TW	1" wall
20TW	20mm wall
25TW	25mm wall

Lens guard

BLANK	No guard
G	Wire guard

Optics

BLANK	Type V optic standard
R1	Type I optic (all mounts minus ceiling)
R1A*	Type I optic (ceiling with conduit 45° counterclockwise from top hat hinge)
R1B*	Type I optic (ceiling with conduit 135° clockwise from top hat hinge)
R3	Type III optic (all mounts minus ceiling)
R3AP*	Type III optic (select when using Appleton® top hat adapter with Champ fixture)
R3A1*	Type III optic (ceiling with conduit 45° counterclockwise from top hat hinge)
R3A2*	Type III optic (ceiling with conduit 135° clockwise from top hat hinge)
R3B1*	Type III optic (ceiling with conduit 45° clockwise from top hat hinge)
R3B2*	Type III optic (ceiling with conduit 135° counterclockwise from top hat hinge)

*Available with ceiling mount modules only.

Accessories & options†

S812	Trunnion mount kit with pin (available with ceiling mount only)
S831	Safety cable
S890	Quick clip
S892*	Redundant driver
TB6**	Six-pole terminal block

†Ordered with fixture or available separately.

*Available for VMVL-7, 9, 11 and 13 only

**For NEC/CEC only.

Voltage‡

UNV1	100-277 VAC, 50/60 Hz; 127-250 VDC
UNV34	347-480 VAC, 50/60 Hz

‡IEC voltage; 100-240 VAC at 50/60 Hz.

Lens material

BLANK	Clear glass
S891	Diffused glass
S896*	Teflon coated lens
S903	Polycarbonate
UPLT**	Uplight refractor lens

*For NEC/CEC only.

**Recommended for use with Type V optic

Accessories (ordered separately)

Replacement driver kits

VMVL-3-5-7L-UNV1-DRIVER-KIT	UNV1 replacement driver kit for VMVL-3, -5 and -7
VMVL-9-11L-UNV1-DRIVER-KIT	UNV1 replacement driver kit for VMVL-9 and -11
VMVL-96W-13L-UNV1-M2-DRIVER-REPL-KIT	UNV1 replacement driver kit for VMVL-13
VMVL-3L-5L-UNV34-DRIVER-KIT	UNV34 replacement driver kit for VMVL-3 and -5
VMVL-7L-UNV34-DRIVER-KIT	UNV34 replacement driver kit for VMVL-7
VMVL-9L-UNV34-DRIVER-KIT	UNV34 replacement driver kit for VMVL-9
VMVL-11L-UNV34-DRIVER-KIT	UNV34 replacement driver kit for VMVL-11
VMVL-13-M2-DRIVER-KIT	UNV34 replacement driver kit for VMVL-13
VMVL-7L-S892-UNV1-DRIVER-KIT	UNV1 replacement redundant driver kit for VMVL-7
VMVL-9L-11L-S892-UNV1-DRIVER-KIT	UNV1 replacement redundant driver kit for VMVL-9 and 11
VMVL-13-UNV1-S892-M2-DRIVER-KIT	UNV1 replacement redundant driver kit for VMVL-13
VMVL-7L-S892-UNV34-DRIVER-KIT	UNV34 replacement redundant driver kit for VMVL-7
VMVL-9L-S892-UNV34-DRIVER-KIT	UNV34 replacement redundant driver kit for VMVL-9
VMVL-11L-S892-UNV34-DRIVER-KIT	UNV34 replacement redundant driver kit for VMVL-11
VMVL-13-UNV34-S892-M2-DRIVER-KIT	UNV34 replacement redundant driver kit for VMVL-13
VMVL-AL-GL-UNV1-DRIVER-KIT	UNV1 replacement driver kit for amber or green models

Mounting & hardware

VMVL S812 K1	Trunnion mount kit with pin*
VMVL S812 K1 DBR	PVC coated trunnion mount kit with pin*
VMVL S831 K1	Safety cable
VMVL S890 K1	Quick Clip

*Available with ceiling mounted modules only.

Mounting adapters

CHMM1	Mounting adapter for Appleton MercMaster III mounts
CHMM2	Mounting adapter for MercMaster II mounts
CHMM3	Mounting adapter for Thomas & Betts HazLux mounts
CHMM4	Mounting adapter for GE H2 Filtr-Gard mounts

Refractor kit

PVML-UPLT-KIT	Uplight refractor lens
----------------------	------------------------

Photocells

D2S20	Photocell, 120V
D2S208 277	Photocell, 208-277V

Lens guard

P3001	Wire guard
--------------	------------

Dimensions

Stanchion - 25° angled

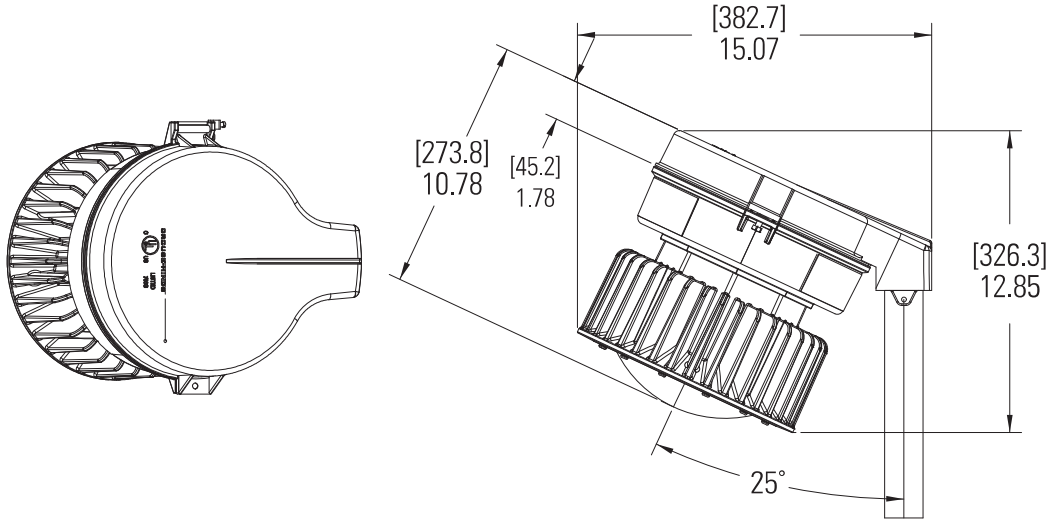

Stanchion - straight

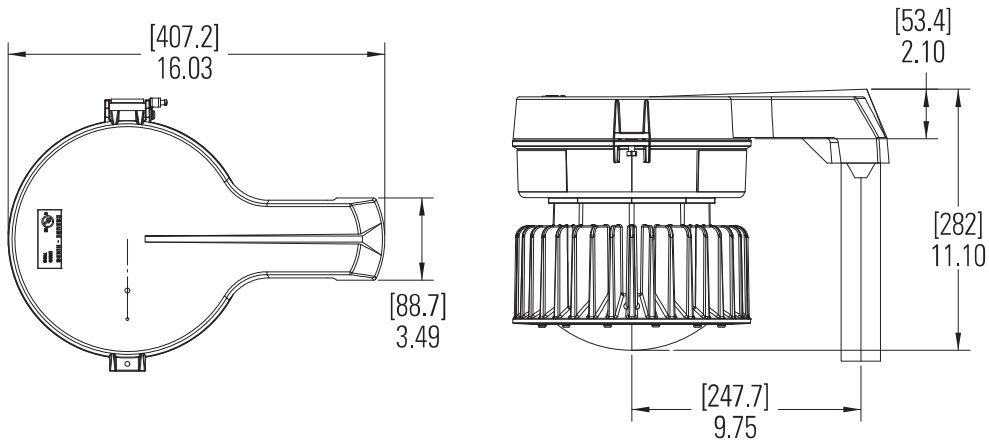

Pendant

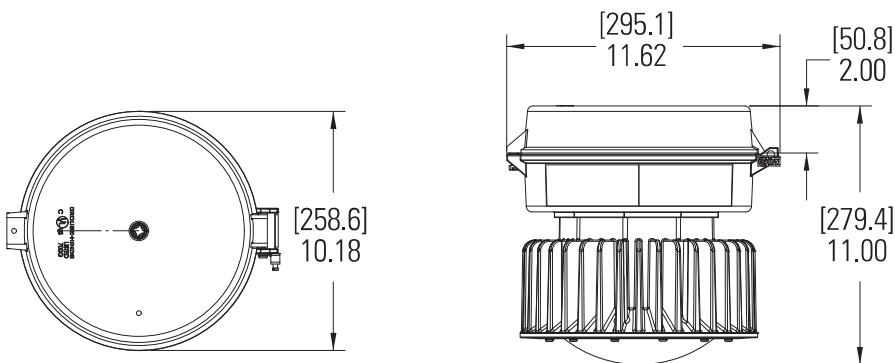

Photometric comparison at 15 ft. mounting height

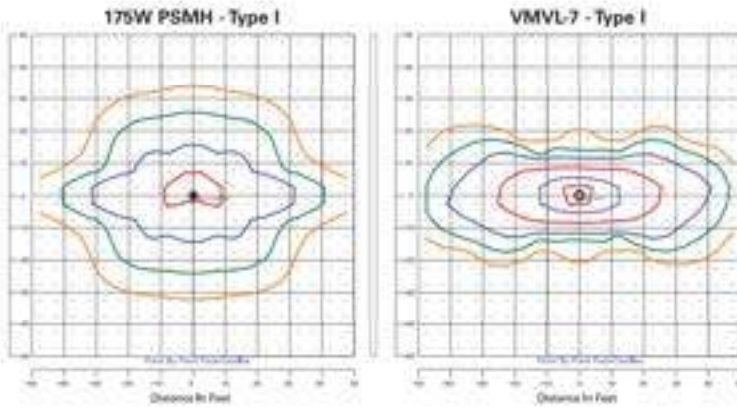

Type I optical pattern



Calculation summary

Label	Calc. type (in Fc)	Avg.	Max.	Min.
VMV 175W MH grid	Illuminance	0.45	2.8	0.0
VMV LED grid	Illuminance	0.62	8.0	0.0

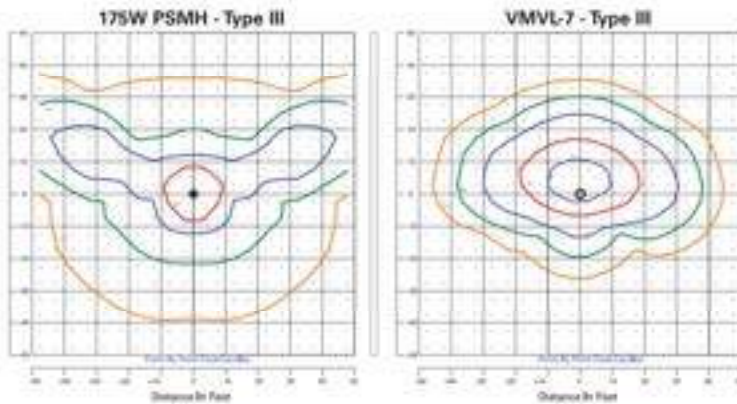

Type III optical pattern



Calculation summary

Label	Calc. type (in Fc)	Avg.	Max.	Min.
VMV 175W MH grid	Illuminance	0.53	3.2	0.1
VMV LED grid	Illuminance	0.61	7.5	0.0

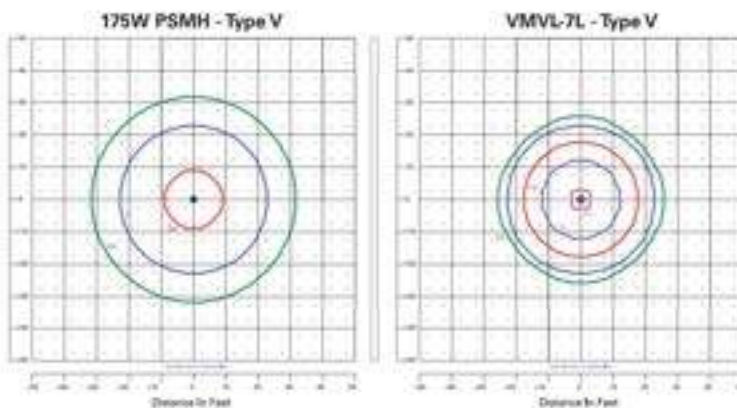

Type V optical pattern



Calculation summary

Label	Calc. type (in Fc)	Avg.	Max.	Min.
VMV 175W MH grid	Illuminance	0.51	2.8	0.1
VMV LED grid	Illuminance	0.69	10.1	0.0

Higher average footcandles, uniformity and distribution coverage with less than half the lumens and energy consumption compared to 175W metal halide

Actual lumens (nominal†)	VMVL-3	VMVL-5	VMVL-7	VMVL-9	VMVL-11
Type I	3,360	5,045	6,844	8,823	10,730
Type III	3,309	4,468	6,741	8,618	10,660
Type V	3,250	5,537	7,442	9,234	11,114

†Tolerance +/- 10%.

LUMINAIRE CLASSIFICATION SYSTEM (LCS) GRAPH

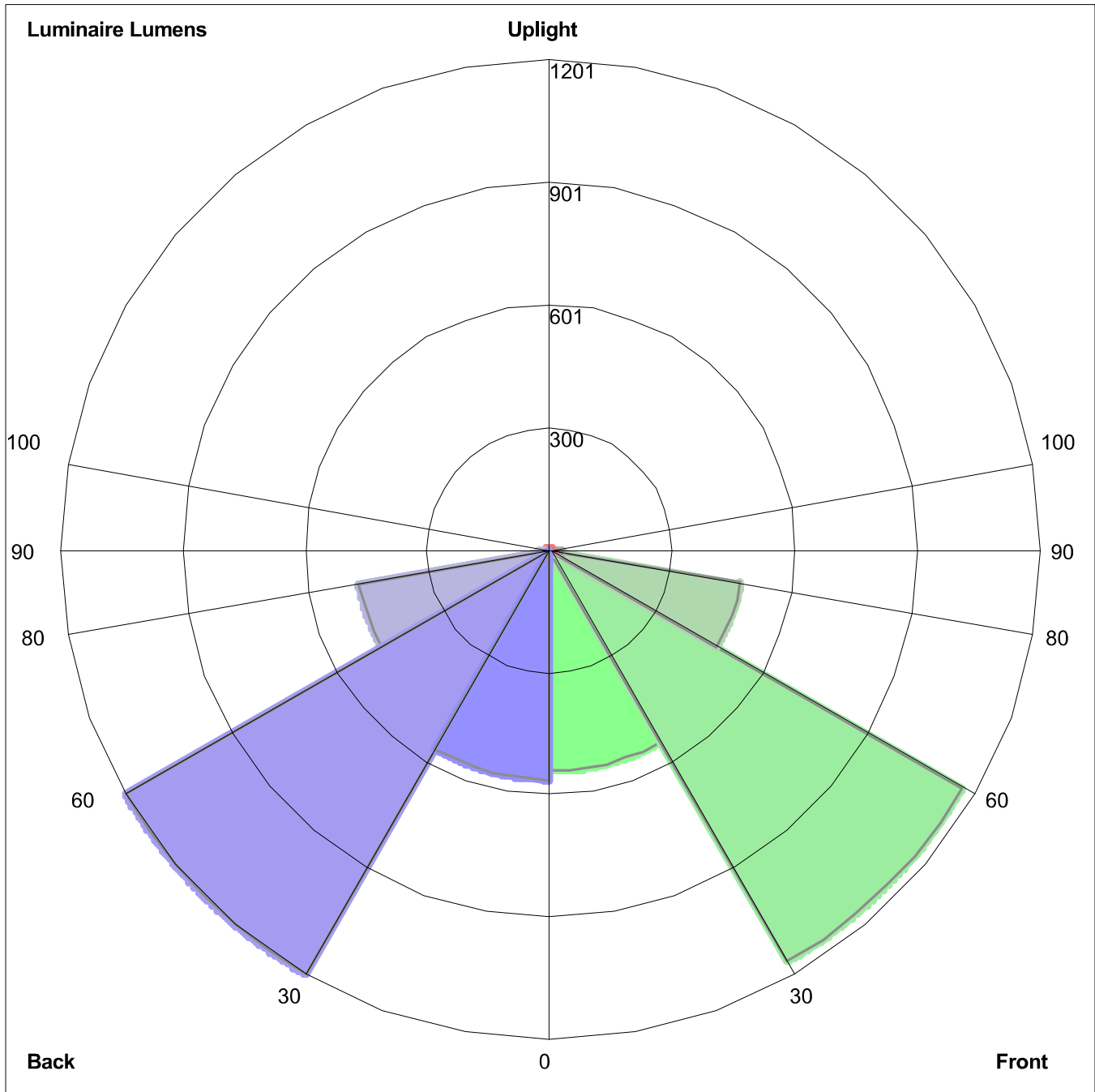

Luminaire Lumens:
Front: Low=543.4, Medium= 1167.0, High=473.2, Very High=31.6
Back: Low=562.9, Medium=1201.1, High=475.9, Very High=30.5
Uplight: Low=7.5, High=0.0

BUG Rating : B2-U1-G1