

K.P. Kauffman Company, Inc.
Sierra-Mitchell 32-3
API # 05-005-06973
NESW Section 32 T4S R63W
Arapahoe County, Colorado

GAS CAPTURE PLAN

K.P. Kauffman, (KPK), has drafted this plan to comply with Rules 903.d and 903.e.(1).B.

This existing location was constructed in 1990. It consists of the wellhead, a separator, an oil storage tank, and a produced water storage tank.

This location has an APEN with CDPHE, AIRS ID 005-1619.

This location was connected to a gathering system that was permanently abandoned by the third-party gathering company.

This is not a request for Venting or Flaring.

903.d: Emissions During Production	Natural gas production is minimal. KPK is utilizing the natural gas to run production equipment onsite.
903.e.(1).B.i: Description of the Closest Gas Gathering System	There is an active gas gathering line approximately 1.5 miles away to the northeast.
903. e.(1).B.ii: Company operating the closest Gas Gathering System	Colorado Interstate Gas
903. e.(1).B.iii: Operator's Plan to Connect	KPK currently has no plans to connect this well to the available gathering system. The well does not produce enough gas that would offset the impacts of constructing such a long lateral to tie in to the system.
903. e.(1).B.iv: Production Test Plans	This well has been producing since 1990.

903. e.(1).B.v: Safety Risks	KPK does not currently anticipate any safety concerns that would result in gas being allowed to escape to the atmosphere. Natural gas is piped on location in a manner to be utilized for running production equipment or excess gas is routed to the ECD for combustion.
903. e.(1).B.vi: Operational BMPs	During all maintenance activities, KPK will have appropriate control equipment onsite to minimize any venting during active and planned maintenance activities.
903. e.(1).B.vii: Procedures to reduce well liquids unloading events	KPK does not currently anticipate any Well Liquids Unloading Events being required.
903. e.(1).B.viii: Anticipated volumes of liquids and gas production	This well averages 1 bbl of oil per month, 2 mcf of natural gas per month, and 0 bbls of produced water per month.



Sierra-Mitchell 32-3

K.P. Kauffman Company, Inc.
Nearest Gas Gathering Line Map
Sierra-Mitchell #32-3
API # 05-005-06973
NESW Section 32 T4S R63W

Legend



Gas Pipeline

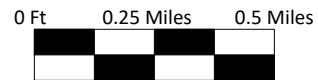

Prepared By:
Ardor Environmental LLC

January 7, 2021

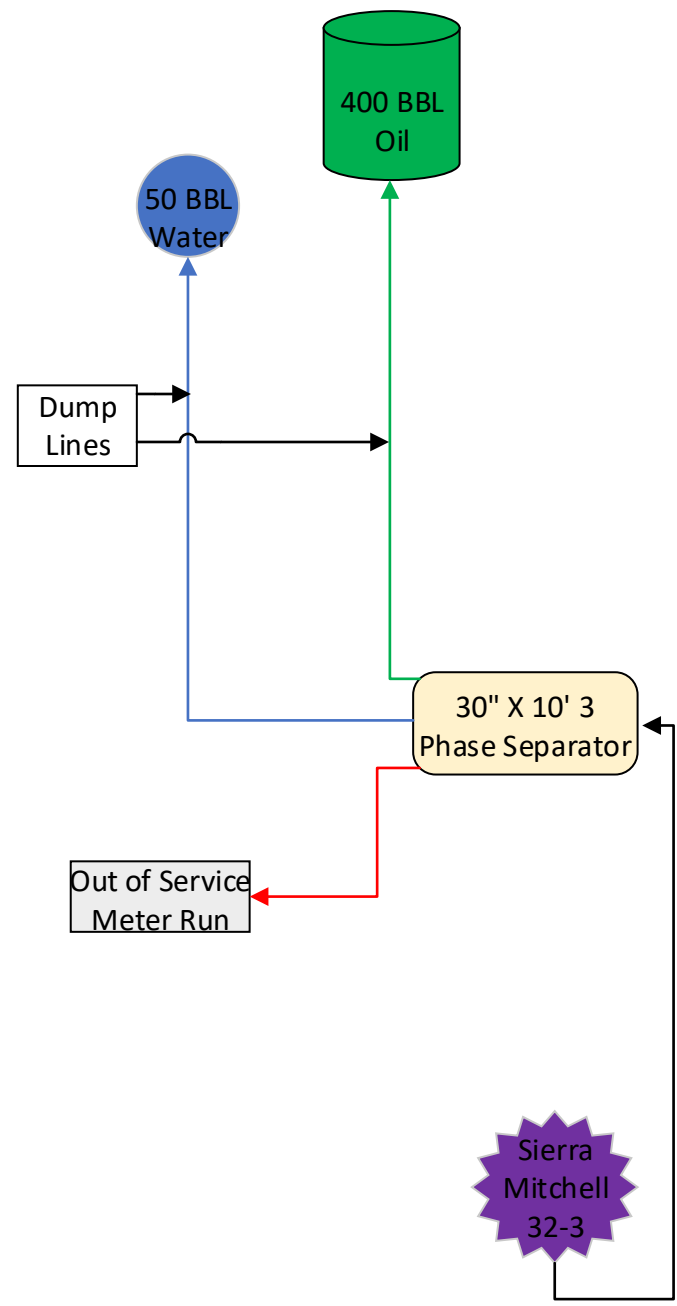

**Sierra Mitchell #32-3 Battery
Process Flow Diagram
NESW Section 32 - 4S - 63W
Arapahoe Co., CO**