



November 7, 2017

Colorado Oil and Gas Conservation Commission
1120 Lincoln Street, Suite 801
Denver, CO 80203

RE: Proposed Wellbore Spacing Unit
Wilson IC 03-142HN
Niobrara New Drill
NWNW Sec. 1, Township 3N, Range 68W, 6th P.M.
Weld County, Colorado

Dear Director Lepore,

Great Western Operating Company, LLC (Great Western) is planning to drill the above captioned well in accordance with the provisions of Colorado Oil and Gas Conservation Commission (COGCC) Rule 318A.e.

Great Western's proposed wellbore spacing unit consists of:

Township 3N, Range 68W (Weld County):
Section 2: All
Section 3: All

Total Acres: 1280 ac

The 30 day notification time period has passed and we have not yet received any objections to such well locations or proposed spacing unit, therefore Great Western hereby requests the Director to approve the above mentioned well. Great Western respectfully requests the COGCC review the enclosed map illustrating the proposed wellbore spacing unit.

Respectfully,

Miracle Pfister

Miracle Pfister
Regulatory Manager
Great Western Operating Company, LLC

WILSON IC 03-142HN
NW 1/4 NW 1/4, SECTION 1, T3N, R68W, 6th P.M.
WELD COUNTY, COLORADO

BASIS OF BEARINGS
BASIS OF ELEVATION
USGS COOPERATIVE BASE NETWORK CONTROL STATION,
DESIGNATION 'VERMILYEA'. NGS DATA SHEET LISTS THE NAVD
88 ELEVATION AS BEING 5026 FEET.

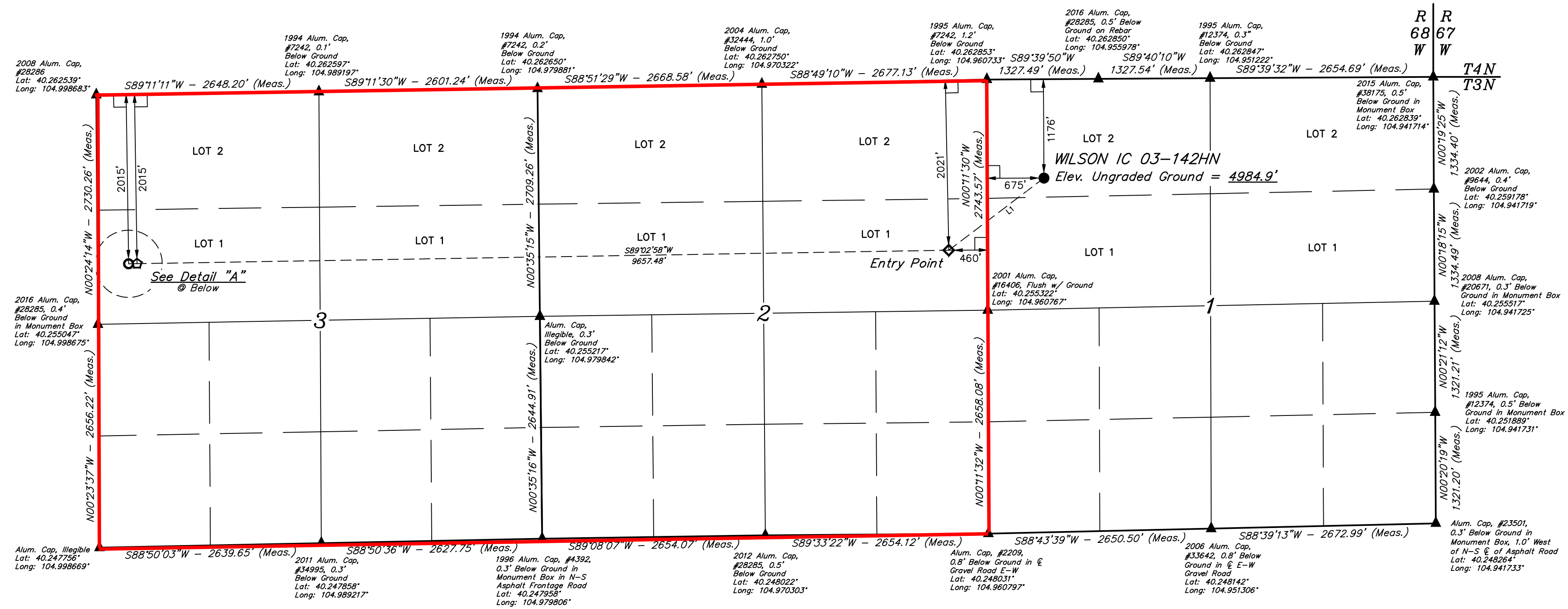
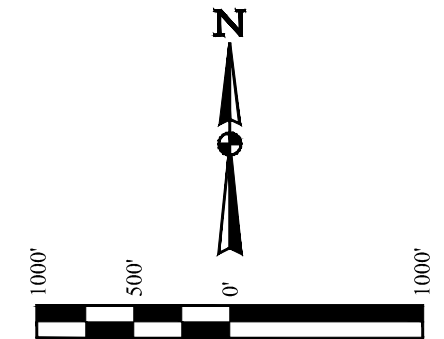

See Detail "A"
Below

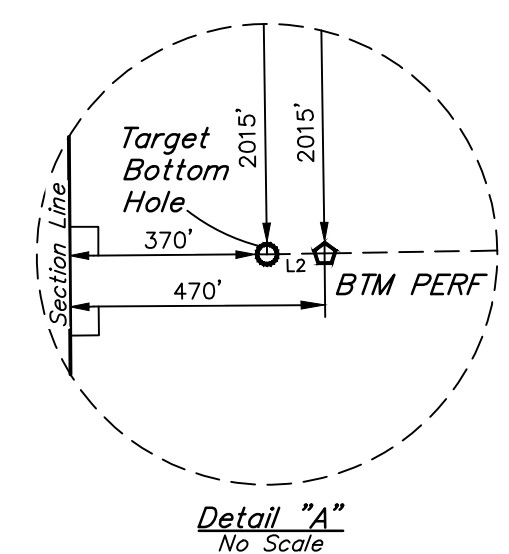

LINE	DIRECTION	LENGTH
L1	S52°50'04"W	1420.69'
L2	S89°11'11"W	100.00'

CERTIFICATE OF REGISTRATION
THIS IS TO CERTIFY THAT THE ABOVE...
NOTES OF ACTUAL SURVEYS MADE...
AND THAT THE SAME ARE TRUE AND CORRECT TO THE BEST OF MY
KNOWLEDGE AND BELIEF.

RECORDED LAND SURVEYOR
REGISTRATION NO. 28285
STATE OF COLORADO

REV: 3 10-05-17 K.B. (BTM PERF ADD & TBH CHANGE)

- LEGEND:
- = 90° SYMBOL
 - = PROPOSED WELLHEAD.
 - ◆ = ENTRY POINT.
 - = BTM PERF.
 - = TARGET BOTTOM HOLE.
 - ▲ = SECTION CORNERS LOCATED. (NAD 83)

NAD 83 (SURFACE LOCATION)	NAD 83 (ENTRY POINT)	NAD 83 (BTM PERF)	NAD 83 (TARGET BOTTOM HOLE)
LATITUDE = 40°15'34.64" (40.259622)	LATITUDE = 40°15'26.24" (40.257289)	LATITUDE = 40°15'25.27" (40.257019)	LATITUDE = 40°15'25.26" (40.257017)
LONGITUDE = 104°57'29.98" (104.958328)	LONGITUDE = 104°57'44.66" (104.962406)	LONGITUDE = 104°59'49.18" (104.996994)	LONGITUDE = 104°59'50.47" (104.997353)
NAD 27 (SURFACE LOCATION)	NAD 27 (ENTRY POINT)	NAD 27 (BTM PERF)	NAD 27 (TARGET BOTTOM HOLE)
LATITUDE = 40°15'34.70" (40.259639)	LATITUDE = 40°15'26.30" (40.257306)	LATITUDE = 40°15'25.33" (40.257036)	LATITUDE = 40°15'25.32" (40.257033)
LONGITUDE = 104°57'28.07" (104.957797)	LONGITUDE = 104°57'42.74" (104.961872)	LONGITUDE = 104°59'47.26" (104.996461)	LONGITUDE = 104°59'48.54" (104.996817)

PDOP = 1.4

UWENTH
UNIVERSITY OF WYOMING

UELS, LLC
Corporate Office • 85 South 200 East
Vernal, UT 84078 • (435) 789-1017

SURVEYED BY ZANE BULLARD, G.W. 04-11-16 SCALE
DRAWN BY M.F.D. 07-21-16 1" = 1000'

WELL LOCATION PLAT