

Appendix 6: Spill Prevention, Countermeasure and Control Plan

SPILL PREVENTION, CONTROL, AND COUNTERMEASURE PLAN

**North Parachute Mountain
Garfield County, Colorado**



Encana Oil & Gas (USA) Inc.

Parachute, Colorado

APRIL 2013 Rev. 1

TABLE OF CONTENTS

1	GENERAL INFORMATION	1-1
1.1	Introduction.....	1-1
1.2	Location and Definition of Plan Area	1-2
1.3	Contact Information	1-2
1.4	Management Approval and Commitment of Resources	1-3
1.5	Substantial Harm Certification	1-3
1.6	Professional Engineer Certification.....	1-4
1.7	Plan Location.....	1-5
2	FACILITY DESCRIPTIONS	2-1
2.1	Physical Layout, Operations, and Facilities	2-1
2.2	Bulk Storage and Container Data.....	2-1
2.3	Secondary Containment and Drainage Control	2-1
2.4	Analysis of Equipment Failure	2-2
2.5	Temporary, Mobile, and Portable Containers	2-2
2.6	Flowlines and Intra-Facility Gathering Lines.....	2-3
2.7	Oil-Filled Operational Equipment.....	2-3
3	INSPECTIONS, TESTING, AND MAINTENANCE	3-1
3.1	Inspections	3-1
3.1.1	Field Constructed Aboveground Containers	3-1
3.1.2	Shop-Build Containers	3-2
3.1.3	Pressure Vessels	3-2
3.1.4	Produced Water Pits/Ponds	3-2
3.1.5	Portable Containers	3-2
3.1.6	Pipelines	3-3
3.1.7	Field Drainage Systems	3-3
3.1.8	Inspection Schedule and Documentation.....	3-4
3.2	Maintenance and Testing	3-4
3.2.1	Aboveground Piping/Pipeline Maintenance and Monitoring	3-4
3.2.2	Container Maintenance and Testing	3-6
3.2.3	Maintenance and Testing Schedule and Documentation	3-6

4	OIL HANDLING PROCEDURES	4-1
4.1	Loading and Unloading Racks.....	4-1
4.2	Loading and Unloading Procedures	4-1
4.3	Intra-Facility Transfer Procedures	4-2
4.4	Drainage Control Procedures	4-2
4.5	Oil Drilling and Workover Operations	4-3
5	COUNTERMEASURE AND SPILL RESPONSE.....	5-1
6	TRAINING.....	6-1
7	PLAN MAINTENANCE	7-1
7.1	Amendments By Owners or Operators.....	7-1
7.2	Amendments By Regional Administrator	7-1
8	RECORDKEEPING	8-1
9	CONFORMANCE WITH 40 CFR 112 AND STATE SPCC REQUIREMENTS AND NEEDED MODIFICATIONS.....	9-1
9.1	CONFORMANCE WITH RULE REQUIREMENTS AND NEEDED MODIFICATIONS.....	9-1
9.2	CONFORMANCE WITH STATE-SPECIFIC SPCC REQUIREMENTS	9-1

LIST OF TABLES

Table 1	Facility List
Table 2	Emergency Contact List
Table 3	Bulk Storage Containers/Secondary Containment (See Field Notebook)
Table 4	Analysis of Equipment Failure (See Field Notebook)

LIST OF FIGURES

Figure 1	Field Location Map
Figures	Facility Diagrams (See Field Notebook)

LIST OF APPENDICES

Appendix A	Certification of Applicability of Substantial Harm Criteria
Appendix B	Oil Spill Contingency Plan
Appendix C	Inspection Forms (See Field Notebook)
Appendix D	Plan Review and Amendment Logs
Appendix E	Spill History Form (See Field Notebook)
Appendix F	Secondary Containment Calculations (See Field Notebook)

ACRONYMS

API	American Petroleum Institute
ARC	annual regulatory compliance
AST	above ground storage tank
ASTM	American Society for Testing and Materials
Bbl	barrel(s), US petroleum, 42 gallons
BLM	Bureau of Land Management, U.S. Department of the Interior
BMPs	Best Management Practices
BOP	blow out preventer
CDP	central delivery point
CDPHE	Colorado Department of Public Health and Environment
CFR	Code of Federal Regulations
COGCC	Colorado Oil and Gas Conservation Commission
DAF	dissolved air floatation
EPA	U.S. Environmental Protections Agency
FRP	Facility Response Plan
IMS	Incident Management System
MOC	Management of Change system
OSCP	Oil Spill Contingency Plan
SPCC	Spill Prevention, Control, and Countermeasures
STI	Steel Tank Institute
UL	Underwriters Laboratory, Inc.
UST	underground storage tank
WTF	water treatment facility

Regulatory Cross Reference Matrix

40 Code of Federal Regulations (CFR) Part	Requirement	SPCC Plan Section
112.3 (a)	Amend plan as necessary per updated regulations	1.1
112.3 (c)	Plan requirement for mobile drilling or workover rigs	4.5
112.3 (d)	Professional engineer certification	1.6
112.3 (e)	Maintain a copy of plan at facility (location of plan)	1.7
112.4	Report certain discharges to EPA	7.2
112.5 (a)	Amend plan following significant changes to the facility	7.1
112.5 (b)	Review plan at least every five years and amend if appropriate	7.1
112.7	Management approval of plan	1.4
112.7	Provide a cross reference matrix to regulations	1-1
112.7	Discuss needed facilities, equipment, or procedures not yet operational in separate paragraphs	9
112.7 (a)(1)	Discussion of facility's conformance with the regulations	9
112.7 (a)(2)	Equivalent environmental protection is allowed for deviations from portions of regulations. Reasons for non-conformance must be stated.	9
112.7 (a)(3)	Describe the physical layout of the facility. Provide a facility diagram including tanks, underground tanks, storage areas for mobile containers, produced water containers, associated piping, transfer stations, connecting pipes and intra-facility gathering lines.	Figures (See Field Notebook)
112.7 (a)(3)(i)	Plan must include type of oil in each container and capacity of each container	2.2
112.7 (a)(3)(ii)	Discharge prevention measures including procedures for oil handling at loading/unloading areas	4.2
112.7 (a)(3)(iii)	Drainage control around containers and other equipment	2.3
112.7 (a)(3)(iv)	Countermeasures for discharge discovery, response and cleanup.	5
112.7 (a)(3)(v)	Methods of disposal of recovered materials	5
112.7 (a)(3)(vi)	Contact list including phone numbers	1.3
112.7 (a)(4)	Discharge reporting procedures, information to be included	5
112.7 (a)(5)	Organize plan to make it useful in an emergency	APP B
112.7 (b)	Provide an equipment failure analysis including sources, quantity,	2.4

40 Code of Federal Regulations (CFR) Part	Requirement	SPCC Plan Section
	direction, and rate of flow	
112.7 (c)	General secondary containment requirement (typical failure mode and most likely quantity) for areas from which a discharge could occur by at least one of eight specified measures	2.3
112.7 (d)	If necessary provide an explanation of impracticability of secondary containment, conduct periodic integrity testing of containers and periodic integrity and leak testing of valves and piping	9.1
112.7 (d)(1)	For impracticability, provide an oil spill contingency plan per part 109	APP B
112.7 (d)(2)	For impracticability, provide written commitment of manpower, equipment, and materials	1.4
112.7 (e)	Written procedures for inspections and tests	3
112.7 (e)	Records of inspections must be signed and kept with plan for three years	8
112.7 (f)(1)	Train oil handling personnel	6
112.7 (f)(2)	Designate an individual accountable for discharge prevention	1.4
112.7 (f)(3)	Conduct an annual discharge prevention briefing	6
112.7 (g)	Security	N/A
112.7 (h)(1)	Provide sized secondary containment (largest compartment on tanker) for loading/unloading racks	4.2
112.7 (h (2)	Provide systems to prevent truck departure before disconnection	4.2
112.7 (h)(3)	Inspect truck prior to filling and departure	4.2
112.7 (i)	Evaluate field constructed containers for brittle fracture failure when containers are altered or repaired	3.2.2
112.7 (j)	Compliance with State requirements	0
112.7 (k)	Qualified oil-filled operational equipment – alternative to general secondary containment requirements	2.7
112.7 (k)(2)(i)	If no secondary containment -Prepare inspection procedures or monitoring program	2.7
112.7 (k)(2)(ii)	If no secondary containment –Provide an oil spill contingency plan per part 109	APP B

40 Code of Federal Regulations (CFR) Part	Requirement	SPCC Plan Section
112.7 (k)(2)(ii)	If no secondary containment provide written commitment of resources	1.4
112.9 (b)(1)	Oil production facility drains of dikes must be kept closed. Inspect diked areas before draining water and remove accumulated oil.	4.4
112.9 (b)(2)	Inspect field drainage systems, oil traps, sumps or skimmers for oil. Remove accumulated oil	3.1.7
112.9 (c)(1)	Material and construction of containers must be compatible with stored material and conditions of storage	2.2
112.9 (c)(2)	Provide sized secondary containment (capacity of largest container plus precipitation) for tank battery, separation, and treating facility installations	(See Field Notebook)
112.9 (c)(2)	Confine drainage from undiked areas to catchment basin or holding pond	4.4
112.9 (c)(3)	Visually inspect containers, foundations, and supports periodically and on a regular schedule	3.1
112.9 (c)(4)	Engineer tank batteries to prevent discharges with one of the following features:	3.2.2
112.9 (c)(4)(i)	Provide adequate tank capacity to prevent overfilling, or	3.2.2
112.9 (c)(4)(ii)	Provide overflow equalizing lines between containers, or	3.2.2
112.9 (c)(4)(iii)	Provide vacuum protection to prevent collapse, or	3.2.2
112.9 (c)(4)(iv)	Provide high level sensors	3.2.2
112.9 (c)(5)	Alternative to sized secondary containment for some flow through process vessels	N/A
112.9(c)(5)(i)	Periodically and regularly inspect and/or test flow through process vessels and associated components	N/A
112.9(c)(5)(ii)	Take corrective action as indicated by inspections or tests or evidence of oil	N/A
112.9(c)(5)(iii)	Remove or stabilize and remediate any accumulation of oil	N/A
112.9 (c)(6)	Alternative to sized secondary containment for some produced water containers	3
112.9 (c)6(i)	Implement a procedure to remove free-phase surface oil. Include	3

40 Code of Federal Regulations (CFR) Part	Requirement	SPCC Plan Section
	written procedures, frequency, amount of oil expected inside container, and a PE certification. Maintain records of these activities.	
112.9 (c)6(ii)	On a regular schedule visually inspect and/or test produced water containers and associated piping	3
112.9 (c)6(iii)	Take corrective action as indicated by inspections or tests or accumulation of oil	3
112.9 (c)6(iv)	Promptly remove or stabilize and remediate accumulation of oil	3
112.9 (d)(1)	Periodically and regularly inspect aboveground valves, piping, drip pans, supports, and pumps associated with transfer operations	3.1.6
112.9 (d)(2)	Inspect salt water disposal facilities	3.1.4
112.9 (d)(3)	For flowlines and intra-facility gathering lines without secondary containment provide:	2.6
112.9 (d)(3)(i)	Oil spill contingency per Part 109 and	APP B
112.9 (d)(3)(ii)	Written commitment of resources	1.4
112.9(d)(4)	Prepare and implement a flowline maintenance program including:	3.2.1
112.9(d)(4)(i)	Ensure materials are compatible with fluids	3.2.1
112.9(d)(4)(ii)	Visually inspect or test flowlines and intra-facility gathering lines on a regular and periodic schedule. For lines not having secondary containment the frequency and type of testing must allow for prompt implementation of the contingency plan.	3.1.6
112.9(d)(4)(iii)	Take corrective action as a result of inspections, tests, or evidence of a discharge	3.1.8
112.9(d)(4)(iv)	Promptly remove or stabilize and remediate oil discharges	3.1.8
112.10	Requirements for onshore oil drilling and workover facilities	4.5
112.20 (e) 112.20(f)(1)	Certification of the applicability of substantial harm criteria	1.5

1 GENERAL INFORMATION

1.1 INTRODUCTION

Encana Oil & Gas (USA) Inc.'s (Encana's) North Parachute Mountain Well Field is comprised of 26 well pads for the production of natural gas and 9 central delivery points (CDPs) for the separation and transfer of natural gas, produced water, and oil. Of the 35 facilities located within the North Parachute Mountain Well Field, 21 well pads and one CDP meet the criteria to be included in this Plan. The remaining well pads and CDPs are exempt because they fall below the aggregate threshold for this Plan. Operations within the North Parachute Mountain Well Field include natural gas production, transfer, separation, distribution, and at some sites underground injection. The production process also generates a condensate product that meets the regulatory definition of oil. Containers and pipelines are utilized to process, store, and transfer condensate, produced water, and other oil-containing materials. The individual facilities located in the North Parachute Mountain Well Field that are covered under this plan are described in Section 2.1 and include well pads and bulk storage tanks.

The Oil Pollution Prevention Regulations (40 CFR 112) require preparation of a Spill Prevention, Control and Countermeasure (SPCC) Plan for facilities (as defined 40 CFR 112.2) that have discharged or could reasonably be expected to discharge oil into or on navigable waters of the United States or adjoining shorelines. A SPCC Plan is required to be prepared if greater than 42,000 gallons of oil are stored in buried tanks or greater than 1,320 gallons of oil is stored in aboveground tanks. Because one or more of the facilities falling within the scope of this Multi-Facility SPCC Plan exceeds one or both of the thresholds listed above, a SPCC Plan is required to be prepared and implemented.

The purpose of a SPCC Plan (referred to herein as the Plan) is to describe engineering and administrative controls employed at/by a facility to comply with requirements set forth under 40 CFR 112 to prevent the discharge of oil to navigable waters as well as state-specific rules, regulations and guidelines pertaining to oil spill prevention, control and countermeasure. The contents of this Plan include all applicable requirements listed in 40 CFR 112 as noted in the cross-referencing table located in the Plan preface.

This Plan has been prepared in accordance with those regulations as amended by the Environmental Protection Agency's (EPA) November 13, 2009 final regulatory action and any

more stringent state-specific requirements regarding the prevention, control or countermeasures associated with releases of oil to the environment.

1.2 LOCATION AND DEFINITION OF PLAN AREA

This plan covers facilities within the North Parachute Mountain Well Field north of the Town of Parachute, Colorado (Townships 4 and 5 South, Range 96 West of the 6th Prime Meridian). Operations within this production field include natural gas production, fluid separation, and produced liquid treatment and storage operations making the field subject to 40 CFR 112 and, specifically, section 40 CFR 112.9 for onshore oil production facilities.

Figure 1 depicts the geographic extent of the production field for which this Plan has been developed and implemented. The field is comprised of a number of separate facilities, with each facility containing equipment or sites that are connected via piping. Per EPA guidance, multiple facilities may be accounted for within a single SPCC plan if they reside in the same production field. A list of the specific facilities present in the North Parachute Mountain Well Field and included within the scope of this Multi-Facility SPCC Plan is provided in Table 1, Facilities List.

The facilities are owned and operated by Encana Oil & Gas (USA), Inc. located at 143 Diamond Avenue, Parachute, Colorado 81635. Equipment located at the facilities covered includes wellheads, separation equipment, aboveground piping, produced water pits and storage tanks.

1.3 CONTACT INFORMATION

Contact information specific to the Encana Oil & Gas (USA), Inc. North Parachute Mountain Well Field is provided in Table 2, Emergency Contact List located in the Tables section of this Plan. Emergency notification procedures (including contact information and phone numbers for the National Response Center, state, local entities, and cleanup contractors) are described in detail in the Oil Spill Contingency Plan (OSCP) located in Appendix B of this Plan.

1.4 MANAGEMENT APPROVAL AND COMMITMENT OF RESOURCES

Encana Oil & Gas (USA) Inc. is committed to the prevention of discharges of oil to navigable waters and the environment through the implementation of spill prevention measures. This Plan is one part of that effort.

As an authorized Encana employee, I approve this Plan and the commitment of resources to implement the Plan at these facilities. This resource commitment includes the personnel, equipment, and materials required to expeditiously control and remove any quantity of oil discharged that may be harmful.

Encana Oil & Gas (USA) Inc.

By: _____ Date: _____

Printed Name: _____ Title: _____

The designated responsible person for spill prevention and cleanup at each facility is directly responsible for implementing this Plan and communicating the Plan to appropriate Encana personnel. The designated spill prevention individual for the facilities covered under this Plan reports directly to Encana management and is identified below.

Signature: _____ Date: _____

Printed Name: _____ Title: _____

In addition, specific personnel are identified at the operations level as accountable for discharge prevention at individual the facilities. Those personnel have been identified in Table 2, Emergency Contact List.

1.5 SUBSTANTIAL HARM CERTIFICATION

This facility is not expected to cause substantial harm to the environment by discharging oil into or on the navigable waters or adjoining shorelines and is not required to prepare and submit to the EPA Regional administrator a Facility Response Plan (FRP) in accordance with 40 CFR 112.20. The completed Substantial Harm Certification has been included in Appendix A. As noted on the completed forms, the North Parachute Mountain Well Field does not meet the

Encana acknowledges that the above certification in no way relieves the company of its duty to prepare and fully implement this Plan in accordance with 40 CFR 112.

1.7 PLAN LOCATION

A complete copy of this plan is maintained at the Encana's Parachute, Colorado office. The Plan is available for on-site review during normal working hours at 143 Diamond Avenue, Parachute, Colorado 81635. The SPCC Plan is contained in two parts: 1) the Field Master Plan addresses all applicable requirements of 40 CFR 112; and, 2) the Field Notebooks provide backup information which is referenced in the Master Plan.

2 FACILITY DESCRIPTIONS

This section provides general information regarding oil storage for the North Parachute Mountain Well Field. Field operations include a number of separate facilities. This section identifies those facilities and provides information regarding the equipment and operations undertaken at each facility. The tables and figures described in the following sections provide additional information regarding each of the facilities.

2.1 PHYSICAL LAYOUT, OPERATIONS, AND FACILITIES

The North Parachute Mountain Well Field is a natural gas production field and geographically encompasses two townships. For the purposes of this plan, a facility is referring to well pads or well sites, connected piping, produced water pits and bulk storage tanks. Compressor stations and water treatment facilities are covered under separate SPCC plans.

Figure 1 depicts the geographic extent of the scope of this Plan and additional Figures in the Field Notebooks provide specific site facility diagrams.

This Plan covers well pads/sites in the North Parachute Mountain Well Field that are subject to 40 CFR 112. A listing of facilities covered under the scope of this Plan is provided in Table 1.

2.2 BULK STORAGE AND CONTAINER DATA

Bulk storage containers are not used for the storage of oil unless the container material and its construction are compatible with the material stored and the conditions of storage. The Field Notebooks provides specific information regarding the containers in service at each facility and includes the type of oil in each fixed container and its storage capacity.

2.3 SECONDARY CONTAINMENT AND DRAINAGE CONTROL

Specific secondary containment is required, at a minimum, to contain the contents of the largest container inside the containment area, plus (if exposed to the weather) enough freeboard to hold a significant precipitation event. Encana uses a 24 hour, 25 year storm event for its design criteria. General secondary containment is achieved through utilization of earthen berms, steel containment rings, impervious liner systems, drip pans, and off-loading collection sumps. The containment systems and procedures utilized are designed to be capable of containing oil and

have been constructed so that any discharge from a container, such as a tank, will not escape the containment system before cleanup occurs. Both active and passive secondary containment may be employed in response to a release.

The Field Notebooks provide information regarding the types and capacities of secondary containment structures in place at each facility. The Figures in the Field Notebooks show the locations of all secondary containment structures and the general flow of surface drainage at each facility. The Figures in the Field Notebooks also show the location of various Non-SPCC regulated chemicals and associated secondary containment. This information is included as a BMP and to aid in spill response efforts and is not required by 40 CFR 112.

2.4 ANALYSIS OF EQUIPMENT FAILURE

Where experience has indicated a reasonable potential for equipment failure, an analysis of the typical modes of each type of major equipment failure has been performed. The results of the analysis have been recorded in the Field Notebooks. Although spills that occur within bermed/diked areas would likely be contained, predictions in the following table discount the presence of containment structures, per EPA guidance. In determining the method, design, and capacity of secondary containment structures, typical failure modes and the anticipated quantity of oil that may potentially be released were considered.

There are potential truck loading/unloading areas located adjacent to all produced water pits. Berms, dikes, and retention basins provide general secondary containment on each of these locations. The typical failure at one of these locations would be a tanker hose rupture and could result in a 50 gallon spill.

2.5 TEMPORARY, MOBILE, AND PORTABLE CONTAINERS

Mobile, portable, or temporary containers such as frac tanks and drums may be utilized throughout the facilities for storage of oil-containing liquids. During standard facility operations, a various number of frac tanks may be present in any given area. The anticipated capacity of these containers is estimated to be at 500 bbl each and typically contain produced water. General secondary containment is provided for portable and temporary containers as required by 112.8c (11).

2.6 FLOWLINES AND INTRA-FACILITY GATHERING LINES

The facilities within this field utilize flowlines and/or intra-facility gathering lines. The installation of secondary containment is not practicable at these facilities due to the large geographical extent of the lines. Sections 3.0 and 4.0 of this Plan describe the inspections and monitoring program in greater detail. In addition, an Oil Spill Contingency Plan has been implemented for the North Parachute Mountain Well Field, as shown in Appendix B.

2.7 OIL-FILLED OPERATIONAL EQUIPMENT

The facilities within this field do utilize oil-filled operational equipment.

The equipment is generally located at the CDPs and are generators, pumps, and compressors.

3 INSPECTIONS, TESTING, AND MAINTENANCE

3.1 INSPECTIONS

All inspections conducted to fulfill the requirements of this Plan are performed in accordance with the equipment-specific procedures outlined in the following sections. Encana's Standards, Engineering & Technology Group has implemented an Integrity Management Program which manages the risk associated with loss of containment by limiting the inherent exposure of assets to the following threats:

- Metal loss, including external and internal corrosion and erosion
- Cracking
- Manufacturing and construction defects
- Third party damage
- Operational (including human error)
- Geotechnical

Encana's inspection and maintenance goals focus on constructing, operating, and maintaining assets using benchmark practices for integrity in the oil and gas sector. This focus is also to protect the public, employees, environment, and communities in which we operate. A copy of the Integrity Management Program is available at Encana Oil & Gas (USA), Inc. located at 143 Diamond Avenue, Parachute, Colorado 81635.

All inspections are performed by personnel who are knowledgeable in facility operations, the equipment being inspected, and the characteristics of the materials being processed, stored, or transferred. If, as a result of periodic inspections, corrective actions are needed, the finding and the corrective action are documented in the Field Notebooks. The following sections describe the periodic inspections to be conducted.

3.1.1 Field Constructed Aboveground Containers

Field-constructed aboveground containers are not utilized at facilities covered under this scope of this Plan.

3.1.2 Shop-Build Containers

The facilities within this field utilize shop-built containers that store 55 gallons or more of an oil-containing product or material. Once annually, a visual inspection will be performed on each shop-fabricated container subject to the requirements of this Plan. Shop-fabricated containers shall also have formal external inspection by a certified inspector in accordance with Encana's Integrity Management Program and API 12R1, Recommended Practice for Setting, Maintenance, Inspection, Operation, and Repair of Tanks in Production Service.

Visual inspections shall be performed by personnel who are knowledgeable in facility operations, the tanks and associated components, and the characteristics of the liquids stored. The annual inspections are conducted by an interdisciplinary team trained to identify site-specific compliance concerns related to company policy and pertinent regulatory requirements. The inspections will be documented and recorded in accordance with Encana's Integrity Management Program.

3.1.3 Pressure Vessels

The separators, meter houses, and gas lifts at the North Parachute Mountain Well Field facilities, covered under the scope of this Plan, have informal visual inspections conducted on a frequent basis by operations personnel. These personnel are knowledgeable in facility operations, the tanks and associated components, and the characteristics of the liquids stored. Once annually, a formal inspection will be performed at these facilities.

3.1.4 Produced Water Pits/Ponds

Produced water pits and/or ponds are considered containers for the purposes of this Plan and are utilized within the North Parachute Mountain Well Field and covered in this SPCC plan.

Produced water pits shall be visited daily when in use. When surface oil is noted it is skimmed and removed. Pit skimming records are kept under usual and customary practice. Twice per week a pit report, based on a field visit to the pits, is prepared documenting water levels. Once annually an ARC inspection of these facilities will be performed.

3.1.5 Portable Containers

The facilities within this field utilize portable containers that have the capacity to store 55 gallons or more of an oil-containing product or material such as drums (for liquid storage from

drip pans), diesel trailers or produced water frac tanks. These containers may or may not be on location at any given time.

When in active use, portable containers will be visually at a minimum on a weekly basis by operational personnel.

3.1.6 Pipelines

External visual inspections of facility piping including gathering lines and produced water delivery lines will be performed on a regular basis for aboveground portions of the lines. Appurtenances associated with the lines, such as pipe supports, valves, and rod stuffing boxes, are also evaluated during the line inspections. The aboveground piping, both temporary and permanent, that are actively being utilized to transfer oil-containing product or material will be inspected on a routine basis. Informal daily inspections occur by operations personnel to observe the lines and associated structures and equipment for conditions that could lead to a discharge. Underground sections of pipelines will be visually inspected whenever exposed during excavation work.

General procedures used during the above-referenced inspections include a visual evaluation of the lines and associated structures and equipment for:

- leaks or other oil discharges
- signs of corrosion
- loose bolts or missing plugs
- accumulation in drip pans
- general physical condition of the equipment

Standard procedures for inspecting piping and associated equipment are provided in Encana's Integrity Management Program, available upon request.

3.1.7 Field Drainage Systems

Field drainage systems such as road ditches and drainage ditches, including any oil traps, sumps, or skimmers, will be inspected at regular intervals by operations personnel. Drainage ditches and other drainage-related structures, including catchment basins, weirs, culverts and sumps, as applicable, will be inspected for any problems that may impede drainage of storm waters and for

any accumulations of oil. Accumulations of oil will be removed promptly. Facility drainage system inspections will be recorded, and the records maintained per the requirements of Section 8.0 of this Plan.

3.1.8 Inspection Schedule and Documentation

Inspection schedules for individual equipment items will be maintained at the Encana office in Parachute, Colorado. Completed inspection records will be maintained with a copy of this Plan in accordance with Section 8.0 and will be available for review at the Encana office in Parachute, Colorado. Corrective action will be taken when deficiencies are noted during any inspection or if evidence of a discharge is observed. All observed oil discharges will be promptly removed. Releases noted during routine inspections will be documented in Encana's Incident Management System (IMS).

In response to a discharge, facility personnel utilize Encana's IMS to document and track the event. The IMS is a web-based application for reporting and managing all incidents electronically, including injuries, spills, motor vehicle accidents, and most other types of occurrences. IMS facilitates the centralized first report and the workflow process for investigating incidents and assigning corrective actions, and generates reports for analyzing the occurrence of incidents so that risks can be analyzed and preventive measures can be put in place.

3.2 MAINTENANCE AND TESTING

3.2.1 Aboveground Piping/Pipeline Maintenance and Monitoring

To reduce the potential for discharges, Encana operates a program of aboveground piping/pipeline monitoring and maintenance. Pipelines are maintained in accordance with established integrity management protocols. Such management practices include standards for the selection, installation, monitoring, and maintenance of pipelines as well as associated valves, flanges, and other equipment. All maintenance activities are performed by personnel who are knowledgeable in facility operations and the equipment being maintained.

Procedures for the maintenance of pipelines subject to the requirements of this Plan include the following.

- Prior to installing, replacing, or repairing lines, valves, or associated equipment, facility personnel must ensure compatibility with the materials to be transferred and address potential concerns involving corrosive production fluids, volumes, pressure, and other conditions expected in the operational environment.
- New pipelines are pressure tested before they are put into service.
- Piping is identified on facility maps and is clearly marked in the field to facilitate access and inspection by facility personnel.
- Corrosion rates for pipelines are monitored utilizing weight loss corrosion coupons or equivalent measures as described in Encana's Internal Corrosion Control Guide.
- Spot ultrasonic testing is conducted on pipelines in areas where the line can be accessed. Access cans are utilized where present to evaluate sections of lines that have been identified as having a potentially high corrosion rate. Ultrasonic testing may also be scheduled based on known corrosion issues and to verify the effectiveness of corrosion inhibiting treatment.
- Smart pigging is performed on larger diameter lines on an as needed basis. The wall thickness measurements and corrosion rates provided by data from smart pigging are used to schedule maintenance activities.
- Where practicable:
 - pipelines are protected by treatment with corrosion inhibitor with feed rates of the inhibitor adjusted in proportion to well flows,
 - cathodic protection is provided on lateral lines from metering skids down, on third party lines from master meters down, and on main trunk lines, and
 - pipeline pressure is monitored during transfers by personnel having the ability to remotely close isolation valves in the event of an emergency.
- Where possible, electric water pumps automatically shut down when pressures reach a level that indicate a problem.
- As soon as practicable following the detection of a leak, the affected portion of the line is isolated and repaired or replaced.
- Pipeline pressures are monitored by a networked computer production management system.

The maintenance and testing procedures referenced above are performed on individual sections of lines at a frequency determined by the facility mechanical integrity team. The frequency for maintaining and testing lines located within secondary containment is based on several factors, including the age of the pipeline, known or suspected corrosion issues, materials used in construction, number of elbows, expansions, contractions, etc. The frequency and type of testing prescribed for pipelines that have not been provided with secondary containment will be executed so that the Oil Spill Contingency Plan (Appendix B) for the North Parachute Mountain Well Field may be effectively implemented.

In the event that an inspection or test identifies either the need for repair or evidence of a discharge, corrective action shall be implemented accordingly. For example, any oil discharges associated with pipelines or associated equipment shall be promptly removed.

3.2.2 Container Maintenance and Testing

The installation of new tank batteries, or other containers subject to the requirements of this Plan, as well as updates to existing oil containers tanks must be performed in accordance with good engineering practice to prevent discharges. At least one of the following shall be provided for new containers or when updating existing containers:

- Container capacity adequate to assure that a container will not overflow if a pumper/gauger is delayed in making regularly scheduled rounds
- Overflow equalizing lines between containers so that a full container can overflow to an adjacent container
- Vacuum protection adequate to prevent container collapse during a pipeline run or other transfer of oil from the container
- High level sensors to generate and transmit an alarm signal to the computer where the facility is subject to a computer production control system.

3.2.3 Maintenance and Testing Schedule and Documentation

Maintenance and testing schedules for individual equipment will be maintained at Encana's Parachute, Colorado office. Records of inspections, tests, and corrective actions will be maintained as described in Section 8.0 of this Plan. Releases resulting from the failure of containers, pipelines or other equipment will be documented in Encana's IMS.

4 OIL HANDLING PROCEDURES

The following sections describe the discharge prevention measures that have been established and implemented at the facilities within this production field to aid in preventing oil releases.

4.1 LOADING AND UNLOADING RACKS

The facilities within this field, covered by this Plan, do not utilize a loading and/or unloading rack.

4.2 LOADING AND UNLOADING PROCEDURES

When possible, loading and unloading areas located at the side where tank trucks deliver and pick up product, produced water, and condensate will be provided with general secondary containment.

General procedures implemented at the facilities within the field for the routine loading and unloading of oil products (fuel, lubricating oils, etc.) and oil-containing materials (produced water, condensate, etc.) into and out of cargo vehicles are described below:

- Park vehicle (upwind, if possible) and set brakes
- Use wheel chocks or equivalent measures to prevent unexpected movement
- Connect ground cable to unpainted surface on vehicle frame
- Check hoses and couplings for damage
- Connect loading/unloading hose and vent line to vehicle; if vent line is absent, open all appropriate valves in storage tank and trailer
- Position spill bucket or similar drip catch
- Close valve to storage tank
- Loosen loading hose to allow enough air to drain loading hose dry
- Ensure that any drips from the hose drain into the spill bucket or drip catch
- Disconnect loading hose completely, close load valve, plug and fasten securely
- Ensure that any drips from the hose drain into the spill bucket or drip catch

- Close all valve caps, disconnect hoses, and safely manage any remaining liquids
- Replace all valve caps after pumping is finished and make sure all connections are isolated and capped, and install any required seals
- Disconnect ground cable
- Inspect lowermost drains and valves of the vehicle for discharges/leaks and ensure that they are tightened, adjusted, or replaced as needed to prevent discharges while vehicle is in transit

4.3 INTRA-FACILITY TRANSFER PROCEDURES

General procedures implemented at the facilities within the field for the routine transfer of oil products (fuel, lubricating oils, etc.) and oil-containing materials (produced water, condensate, etc.) into and out of cargo vehicles are described below:

- Prior to transferring material from one vessel to another, check level readings to ensure there is adequate space available in the receiving tank
- Monitor all material transfer operations closely (checking lines, pumps, hoses, etc. for proper operation and signs of leakage)
- Prior to, during, and following their use, inspect produced water delivery lines for leaks, oil discharges, corrosion, and other conditions that could lead to a discharge
- Use absorbent pads, pans, buckets, etc., as needed to prevent drips from contacting the ground.

4.4 DRAINAGE CONTROL PROCEDURES

Following a significant storm event, to ensure adequate capacity is available to contain a release operators overseeing processes where sized containment areas are present work to minimize (to the maximum extent possible) the presence, extent, and duration of standing water within the structure. Procedures implemented at the facilities within the field for the routine drainage of secondary containment structures and equipment includes the following:

- Prior to releasing accumulated water to the ground, field drainage system, or other location external to facility operations, visually inspect the water for signs of possible contamination (an accumulation of oil, visible sheen, unusual color change, etc.). If

accumulated oil is observed, remove the oil and return it to storage or dispose of it in accordance with legally approved methods (water containing oil must not be released).

- Manually control and secure secondary containment drainage valves (where present) in the closed position until a release has been authorized by a responsible member of management. Reseal bypass valves immediately following completion of drainage.
- Maintain adequate records of diked area drainage events.
- Manage material collected in portable secondary containment equipment such as drip pans and buckets appropriately and do not release to the ground.
- Facility drainage from undiked areas subject to spill events should if possible, flow into holding ponds or catchment basins designed to retain spills or return them to the facility. Catchment basins should not be located in areas subject to flooding.
- At tank batteries and separation and treating areas where there is a reasonable possibility of a discharge, maintain closed and sealed drains for dikes, ponds, sumps, and other such containment structures; except when draining uncontaminated water.

4.5 OIL DRILLING AND WORKOVER OPERATIONS

Encana is committed to the prevention of releases during drilling and workover operations. All drilling and workover contractors operating facilities subject to the requirements of 40 CFR 112 on company leases/property must have a separate written SPCC plan for their own operations that meets the requirements of 40 CFR 112.7 and 112.10. The contractor's plan must be implemented before operations are initiated and specifically address the following:

- The positioning or location of drilling and workover equipment so as to prevent spilled oil, fuel, or oily drilling fluids from reaching navigable waters.
- Provisions for the installation, as needed, of catchment basins or diversion structures to intercept and contain discharges.

There are installation requirements for blowout preventer (BOP) assemblies and well control systems before drilling below any casing string or during workover operations. The BOP assembly and well control system must be capable of controlling any well-head pressure that may be encountered while that BOP assembly and well control system are on the well.

5 COUNTERMEASURE AND SPILL RESPONSE

Specific procedures for discharge discovery, response, and cleanup are provided in the Oil Spill Contingency Plan located in Appendix B of this Plan. The OSCP provides information and procedures for reporting a discharge, for taking initial actions to mitigate the effects of the discharge, to determine if evacuation is needed, and for ensuring that recovered materials are disposed of in accordance with applicable legal requirements. Finally, the OSCP also identifies the person at the facility who is accountable for discharge prevention and who reports to facility management.

In response to a discharge, facility personnel utilize Encana's Incident Management System (IMS) to document and track the follow up actions. The IMS is a web-based application for reporting and managing all incidents electronically, including injuries, spills, and motor vehicle accidents. IMS facilitates the centralized first report, the workflow process for investigating incidents and assigning corrective actions, and can be used to generate reports for analyzing the occurrence of incidents so that risks can be analyzed and preventive measures can be put in place.

6 TRAINING

Encana field staff receives general awareness training regarding oil spill prevention, control, and countermeasure planning as part of the company’s orientation program for all new employees and contractors. In addition, facility management has identified personnel who, at the facility level, transfer or otherwise manage produced water or condensate, lubricating/compressor oils, used oil, or any other oil as part of their job function. Such employees have been designated as “oil-handling personnel” and are provided with additional training in the following:

- The operation and maintenance of equipment to prevent discharges
- Discharge procedure protocols
- Applicable pollution control laws, rules, and regulations (including local, state, and federal requirements)
- General facility operations
- The contents of this Plan.

In addition, at least once per year, oil-handling personnel are required to attend a discharge prevention briefing. The briefing must highlight and describe any known discharge that has occurred at the facility within the past year, equipment failures, malfunctioning components, and any recently developed precautionary measures. For purposes of this briefing, a discharge relates to the release of oil in sufficient quantities to cause a violation of water quality standards, results in a visible sheen on the surface of the water, or causes an emulsion or sludge to be deposited beneath the water. This briefing is intended to assure adequate understanding of the purpose, content, and use of this Plan.

Training is conducted through Encana’s training and recordkeeping system, eCademy. Training records are maintained in the eCademy system for general awareness and oil-handling personnel training, discharge prevention briefings, or any additional training events performed in accordance with the requirements of this Plan.

7 PLAN MAINTENANCE

7.1 AMENDMENTS BY OWNERS OR OPERATORS

This Plan will be reviewed and potentially amended whenever there is a failure of the Plan to address a discharge, a change in facility design, construction, operations, or maintenance that materially affects the facility's potential for a discharge. An amendment to this Plan shall be prepared within 6 months of the change and implemented as soon as possible, but not later than 6 months following preparation of the amendment.

This Plan shall be reviewed and evaluated at least once every 5 years and amended to include more effective prevention and control technology, if such technology will significantly reduce the likelihood of a discharge event and has been proven in the field. Any amendment made for the reasons described in the prior sentence must be implemented as soon as possible, but not later than 6 months following preparation of the amendment.

The completion of all reviews and evaluations must be documented with a signed statement. The amendment log located in Appendix D shall include a statement that the reviewer has completed a review and evaluation of the SPCC Plan for the given facility on a specific date and that the Plan will or will not be amended as a result. All technical amendments made to this Plan shall be certified by a registered Professional Engineer.

Changes in facility equipment, operation, or arrangement are documented using Encana's Management of Change (MOC) system. Encana personnel responsible for the maintenance of the SPCC Plan will be notified through the MOC system. Plan reviews and amendments to facility specific documentation will be recorded in Appendix D and scheduled and tracked using Encana's IMS.

7.2 AMENDMENTS BY REGIONAL ADMINISTRATOR

If either of the following occurs:

- An individual facility discharges more than 1,000 gallons of oil into or upon navigable waters or adjoining shorelines in a single event

or

- An individual facility discharges more than 42 gallons of oil in each of two discharge events within any 12-month period,

The facility will submit within 60 days of the above event(s) the following information to the U.S. EPA Regional Administrator, the Colorado Department of Public Health and Environment and the Colorado Oil and Gas Conservation Commission:

- Name of facility
- Your name
- Location of facility
- Maximum storage or handling capacity of the facility and normal daily throughput
- Corrective action and countermeasures you have taken, including a description of equipment repairs and replacements
- An adequate description of the facility, including maps, flow diagrams, and topographical maps, as necessary
- The cause of such discharge, including a failure analysis of the system or subsystem in which the failure occurred
- Additional preventive measures you have taken or contemplated to minimize the possibility of recurrence
- Such other information as the Regional Administrator may reasonable require pertinent to the Plan or discharge.

This Plan shall be amended as required by the Regional Administrator as a result of review of the information submitted.

8 RECORDKEEPING

Written procedures associated with the inspection and testing activities conducted per the requirements of this Plan are available through Encana's document management system. Along with the referenced procedures, records of inspections and tests required by this Plan will be signed by the appropriate supervisor or inspector and retained for a period of three years as routine and customary business practice. Inspection records and associated information will be maintained with a copy of this Plan at Encana's field office at 143 Diamond Avenue, Parachute, Colorado 81635.

Records of training events conducted in accordance with the requirements of this Plan are maintained in Encana's training records database system.

9 CONFORMANCE WITH 40 CFR 112 AND STATE SPCC REQUIREMENTS AND NEEDED MODIFICATIONS

This section includes a discussion of the overall conformance of this Plan and the facilities within the production field with the requirements of 40 CFR 112 and any state rules, regulations, and guidelines pertaining to oil spill prevention, control, and countermeasure that provide additional or more stringent requirements than the federal rules.

9.1 CONFORMANCE WITH RULE REQUIREMENTS AND NEEDED MODIFICATIONS

The structures, equipment and operations associated with each facility within the field are identified in Section 2.1 of this Plan. The operations and equipment covered under this SPCC Plan comply with the requirement stated in 40 CFR 112, the Colorado Department of Public Health and the Environment, and the Colorado Oil and Gas Conservation Commission.

The Colorado Oil & Gas Conservation Commission (COGCC) Exploration and Production (E&P) Waste Management regulations include specific rules regarding produced water pits. Those regulations at Section 902.b require that the pits be operated to provide for 2 feet of freeboard between the top of the wall and the fluid level at all times, and that a system for monitoring and maintaining freeboard shall be employed. Section 902.c. requires that any accumulation of oil or condensate in a pit shall be removed within twenty-four hours of discovery. Only de minimis amounts of hydrocarbons may be present on pit surfaces

The Oil Spill Contingency Plan for the North Parachute Mountain Well Field and BMPs put in place for surface drainage controls are sufficient alternatives to address potential oil discharges and spills.

9.2 CONFORMANCE WITH STATE-SPECIFIC SPCC REQUIREMENTS

Some states have established requirements applicable to SPCC that are more stringent than federal standards or require additional measures to be taken. In the State of Colorado, no state agencies govern the SPCC activities of the oil and gas industry. However, the COGCC provides specific guideline for secondary containment requirements for oil storage containers located in “high” density areas. The requirement for secondary containment in high density areas is 150

percent compared to 110 percent for EPA SPCC. The North Parachute Mountain Field is not located in a high density area. In addition, there are spill reporting requirements specified by the CDPHE and the COGCC.

TABLES

Table 1 – Facility List

<u>North Parachute Mountain Multiple Well Pads</u>
<u>A03</u>
<u>A05</u>
<u>B16</u>
<u>E06</u>
<u>E16</u>
<u>E34</u>
<u>G08</u>
<u>G09</u>
<u>G21</u>
<u>G35</u>
<u>H04</u>
<u>H34</u>
<u>K04</u>
<u>L27</u>
<u>M23</u>

M33

M34

O03 – Exempt (Tanks on site are covered under Story Booster CS SPCC Plan)

N07

B04

B36 – Exempt (No tanks or pits on site)

F25NW – Exempt (No tanks or pits on site)

F26

J25B (Frac Pad)

3-19 Trail Ridge - Exempt (tanks are closed)

5-19 Trail Ridge – Exempt (tanks are closed)

A03 CDP – Exempt (Aggregate below 1,320 gallons on site)

A27 CDP– Exempt (No tanks or pits on site)

D04 CDP – Exempt (No tanks or pits on site)

F09 CDP – Exempt (No tanks or pits on site)

G17 CDP – Exempt (No tanks or pits on site)

I07 CDP – Exempt (No tanks or pits on site)

J25 CDP – Exempt (Aggregate below 1,320 gallons on site)

K22 CDP

K35 CDP – Exempt (No tanks or pits on site)

Table 2 – Emergency Contact List

<u>NORTH PARACHUTE MOUNTAIN WELL FIELD ROUTE</u> Emergency Contact List			
Encana's 24-Hr Environmental On-call Service	Personnel must immediately report all spills and conditions which could lead to a spill to Encana's 24-hr Environmental On-call number.		970-319-9173
Facility	Facility Phone	Facility Response Coordinator	Coordinator Phone
North Parachute Mountain Route	n/a	Doug Rosa <u>North Piceance Production Operations Lead</u>	970-285-2686 Office 970-210-2073 cell
		<u>Carl Turnipseed</u> <u>Production Coordinator</u>	<u>970-285-2609 Office</u> <u>970-930-5057 cell</u>

FIGURES

encana

North Parachute Mountain

Garfield County, Colorado

0 3,200 6,400 Feet

1 inch = 3,000 feet



T004S-R097W

T005S-R097W

T004S-R096W

T005S-R096W

T004S-R095W

T005S-R095W

Encana Site Boundary
 Access Road
 Township Boundary

Surface Ownership

- Not Identified Below (clear)
- EnCana (transparent)
- USFS (transparent)
- BLM (transparent)

Revised: 11/13/2012
C. Hines

APPENDIX A

**CERTIFICATION OF THE APPLICABILITY
OF SUBSTANTIAL HARM CRITERIA**

**CERTIFICATION OF THE APPLICABILITY
OF THE SUBSTANTIAL HARM CRITERIA CHECKLIST**

FACILITY NAME: NORTH PARACHUTE MOUNTAIN WELL FIELD

FACILITY ADDRESS: NORTH OF THE TOWN OF PARACHUTE, GARFIELD COUNTY, COLORADO (TOWNSHIPS 4 AND 5 SOUTH, RANGE 96 WEST OF THE 6TH PRIME MERIDIAN)

Individual Well Pad Certification of the Applicability of Substantial Harm					
Well Pad	Question 1	Question 2	Question 3	Question 4	Question 5
A03	No	No	No	No	No
A05	No	No	No	No	No
B16	No	No	No	No	No
E06	No	No	No	No	No
E16	No	No	No	No	No
E34	No	No	No	No	No
G08	No	No	No	No	No
G09	No	No	No	No	No
G21	No	No	No	No	No
G35	No	No	No	No	No
H04	No	No	No	No	No
H34	No	No	No	No	No
K04	No	No	No	No	No
L27	No	No	No	No	No
M23	No	No	No	No	No
M33	No	No	No	No	No
M34	No	No	No	No	No
O03 – Exempt (Tanks on site are covered under Story Booster CS SPCC Plan)	N/A	N/A	N/A	N/A	N/A
N07	No	No	No	No	No
Date:		Initial:		Page 1 of 3	

B04	No	No	No	No	No
B36 – Exempt (No tanks or pits on site)	N/A	N/A	N/A	N/A	N/A
F25NW – Exempt (No tanks or pits on site)	N/A	N/A	N/A	N/A	N/A
F26	No	No	No	No	No
J25B (Frac Pad)	No	No	No	No	No
3-19 Trail Ridge - Exempt (tanks are closed)	N/A	N/A	N/A	N/A	N/A
5-19 Trail Ridge – Exempt (tanks are closed)	N/A	N/A	N/A	N/A	N/A
A03 CDP – Exempt (Aggregate below 1,320 gallons on site)	N/A	N/A	N/A	N/A	N/A
A27 CDP– Exempt (No tanks or pits on site)	N/A	N/A	N/A	N/A	N/A
D04 CDP – Exempt (No tanks or pits on site)	N/A	N/A	N/A	N/A	N/A
F09 CDP – Exempt (No tanks or pits on site)	N/A	N/A	N/A	N/A	N/A
G17 CDP – Exempt (No tanks or pits on site)	N/A	N/A	N/A	N/A	N/A
I07 CDP – Exempt (No tanks or pits on site)	N/A	N/A	N/A	N/A	N/A
J25 CDP – Exempt (Aggregate below 1,320 gallons on site)	N/A	N/A	N/A	N/A	N/A
K22 CDP	No	No	No	No	No
K35 CDP – Exempt (No tanks or pits on site)	N/A	N/A	N/A	N/A	N/A
Question 1: Does the facility transfer oil over water to or from vessels and does the facility have a total oil storage capacity greater than or equal to 42,000 gallons?					
Date:		Initial:		Page 2 of 3	

<p>Question 2: Does the facility have a total oil storage capacity greater than or equal to 1 million gallons and does the facility lack secondary containment that is sufficiently large to contain the capacity of the largest aboveground oil storage tank plus sufficient freeboard to allow for precipitation within any aboveground oil storage tank area?</p>		
<p>Question 3: Does the facility have a total oil storage capacity greater than or equal to 1 million gallons and is the facility located at a distance (as calculated using the formula in Attachment C-III, Appendix C, 40 CFR 112 or a comparable formula¹) such that a discharge from the facility could cause injury to fish and wildlife and sensitive environments? For further description of fish and wildlife and sensitive environments, see Appendices I, II, and III to DOC/NOAA's "Guidance for Facility and Vessel Response Environments" (Section 10, Appendix E, 40 CFR 112 for availability) and the applicable Area Contingency Plan.</p>		
<p>Question 4: Does the facility have a total oil storage capacity greater than or equal to 1 million gallons and is the facility located at a distance (as calculated using the appropriate formula (Attachment C-III, Appendix C, 40 CFR 112 or a comparable formula¹) such that a discharge from the facility would shut down a public drinking water intake?</p>		
<p>Question 5: Does the facility have a total oil storage capacity greater than or equal to 1 million gallons and has the facility experienced a reportable oil spill in an amount greater than or equal to 10,000 gallons within the last 5 years?</p>		
<p><i>* As noted on the completed spreadsheet, the individual facilities within the North Parachute Mountain Well Field Multi-Facility SPCC Plan do not meet the criteria for substantial harm and thus do not require a Facility Response Plan. The basis for this determination includes the following: 1) Multiple well pads (a.k.a., facilities) have been aggregated into a single SPCC Plan; 2) The total combined oil storage capacity at these facilities is greater than 1 million gallons; and, 3) Each individual facility has been evaluated for SPCC and FRP compliance; non-conformance and needed modifications, if required, are identified in Section 9.0 of this document.</i></p>		
Date:	Initial:	Page 3 of 3

CERTIFICATION

I certify under penalty of law that I have personally examined and am familiar with the information submitted in this document, and that based on my inquiry of those individuals responsible for obtaining this information, I believe that the submitted information is true, accurate, and complete.

Name (please type or print):

Signature:

Title:

Date:

From 40 CFR 112 Appendix C, Attachment C-II

Footnotes:

If a comparable formula is used, documentation of the reliability and analytical soundness of the comparable formula must be attached to this form.

For the purposes of 40 CFR Part 112, public drinking water intakes are analogous to public water systems as described at 40 CFR 143.2(c).

APPENDIX B

OIL SPILL CONTINGENCY PLAN

**Oil Spill Contingency Plan
(Oil Pollution Prevention – 40 CFR Parts 109 and 112)**

Parachute Colorado Facilities

Rifle Surface Water Supply Area – Colorado River

Parachute Creek Surface Water Supply Area – Colorado River

DeBeque Surface Water Supply Area – Colorado River

Plateau Creek Surface Water Supply Area – Colorado River

Encana Oil & Gas (USA) Inc.
143 Diamond Avenue
Parachute, CO 81635

January 2, 2013

Table of Contents

Table of Contents	i
List of Tables	i
List of Figures	ii
List of Appendices	ii
INTRODUCTION	1
ENCANA’S MANAGEMENT COMMITMENT	1
OIL SPILL RESPONSE PROCEDURES	2
Response Management Structure	2
Spill Response Procedures	2
<i>Table 1 – Oil Spill Response Procedures</i>	4
OIL SPILL REGULATORY NOTIFICATION PROCEDURES	6
Verbal Notifications to Government Agencies	6
<i>Information to Provide During Verbal Notifications</i>	7
Written Notifications to Government Agencies	8
<i>State Agencies</i>	8
<i>Federal Agencies</i>	9
CONTACT INFORMATION AND NOTIFICATION PROCEDURES	10
RESOURCES, EQUIPMENT, AND SUPPLIES FOR OIL SPILL RESPONSE	15
INCIDENT TERMINATION	15

List of Tables

Table 1 – Oil Spill Response Procedures
Table 2 – Equipment Shutdown Procedures
Table 3 – Notification Procedures and Contact Information
Table 4 – Contractor Contact Information
Table 5 – Additional Government Agency Phone Numbers
Table 6 – Additional Encana Personnel Contact Information

List of Figures

Figure 1 – Geographic Extent of Parachute Properties/Facilities

List of Appendices

Appendix A – Spill Trailer Inventory and Spill Drum Kit Inventory

Appendix B – References

INTRODUCTION

The Oil Spill Contingency Plan (OSCP) was prepared to meet the requirements of the Environmental Protection Agency's (EPA) Oil Pollution Prevention regulations codified in 40 CFR Parts 109 and 112. The purpose of this OSCP is to define procedures and tactics for responding to unintended discharges of oil originating from bulk storage containers, oil-filled and flow-through equipment, and flowlines within Encana Oil & Gas (USA) Inc.'s (Encana) Facilities managed from Parachute, Colorado. The geographic extent for the facilities is shown on Figure 1. These procedures are implemented whenever a discharge of oil occurs. For the purposes of this Plan, the term "oil" refers to oil-containing liquid (which could include but not limited to produced water, condensate, hydraulic fluids, compressor oil, etc.).

The objective of these procedures is to protect the public, Encana personnel, and other responders during oil discharges. In addition, the procedures are intended to minimize damage to the environment, natural resources, and facility installations from a discharge of oil.

ENCANA'S MANAGEMENT COMMITMENT

Encana is committed to promptly respond to any oil spill which may occur at any Encana facility. This commitment includes both containment and cleanup of any spilled oil with an emphasis on protection of the environment, including surface waters. As an integral part of the Spill Prevention, Control, and Countermeasure Plan (SPCC), this Oil Spill Contingency Plan is one part of that effort.

I approve this Oil Spill Contingency Plan and the commitment of resources needed to implement the plan. This resource commitment includes the properly trained personnel, equipment, and materials required to control and remove any quantity of oil discharged that may be harmful (40 CFR 112.7(d)).

Signature: 

Date: 01/03/13

Printed Name: DAVID GRISSO

Title: OPERATION FIELD LEAD

Signature: 

Date: 1-3-2013

Printed Name: Doug Rosa

Title: OPERATIONS Field LEAD

OIL SPILL RESPONSE PROCEDURES

Response Management Structure

The Environmental Compliance Group (ECG) within Encana is responsible for implementing response procedures in the event of an oil spill or environmental release. These personnel have the authority to commit the resources necessary to carry out a response, and have training and experience in coordinating and managing spill response and clean up efforts. ECG personnel are trained on the Environmental Release Response Standard Operating Procedures (SOP), and have a minimum of 2 weeks “shadowing” experienced ECG personnel responding to incidents. The Environmental Release Response SOP is available at Encana’s Parachute field office.

All oil handling personnel receive training on spill prevention, mitigation, and response, and are familiar with spill reporting and containment objectives. Training records are maintained at Encana’s Parachute field office.

For most spills the designated Spill Coordinator will be the representative from Encana’s ECG who is currently on call. If a spill falls outside the scope of a normal response (i.e. has impacted or threatens to impact waters of the state, has caused a fire, or poses an imminent threat to the safety of Encana personnel or the public); the Authorized Facility Representative may designate a senior Encana employee to act as the Incident Commander, and Encana’s Emergency Response Plan (ERP) would supersede the Oil Spill Contingency Plan (Emergency Spill Response Program). The ERP is available in Encana’s Parachute field office. Should a spill reach waters of the state, Encana’s ECG will provide initial containment and clean up efforts, and will coordinate with local, state, and federal agencies should a more extensive effort be required.

Spill Response Procedures

Spills are generally discovered during normal operations, monitoring, or during the formal inspections carried out in compliance with Encana’s Annual Regulatory Compliance (ARC) Inspections. In addition to the ARC inspections, Encana’s facilities are routinely monitored as part of various tasks (stormwater inspections, maintenance, security checks, etc.). In the event of a spill, all Encana employees and contractors are required to call the Environmental 24-hour On-Call Number (970.319.9173) and their supervisor immediately. If there is an immediate threat to the safety of the public or to operating personnel, local emergency response (911) and Encana’s Safety On-Call (970.210.8755) should be notified first. When reporting a spill, personnel should be prepared to supply the information detailed in the “Environmental On-Call Reporting Requirement” portion of Table 1. This information will allow the on call representative from Encana’s Environmental Compliance Group (ECG), acting as the Spill Coordinator, to make an over-the-phone assessment of the magnitude of the spill. The Spill Coordinator, will make required notifications to the Encana management structure, and mobilize any additional

resources which may be required to respond to the spill appropriately. After required notifications have been made to Encana management, the Spill Coordinator may travel to the spill location to provide a more comprehensive assessment of the situation; mobilize additional resources if necessary; and provide guidance to clean up crews. Table 1 provides the basic steps in Encana's Oil Spill Response Procedures.

The response action taken may vary depending on the severity of the oil spill. Stopping or shutting down the source of the spill is a prime factor in gaining control and mitigating the environmental incident. Equipment must be shut down promptly (such as shutting in the well supplying oil to a flowline or tank battery). Temporary land-based containment measures include putting up berms or dikes across low areas, digging diversion ditches or trenches to intercept overland oil flow or putting barriers or weirs across stormwater ditches. Every effort will be made to keep oil from reaching surface waters. In the event that oil reaches surface water, booms or barriers can be placed to collect oil and prevent further impacts. Impounded oil can be removed by skimming with sorbent pads or by vacuum trucks. A large uncontrolled spill that has the potential to reach surface water may necessitate securing contractor resources with specialized equipment for an effective response. Table 2 references the general shut down procedures based on various sources of a spill or discharge. Equipment shut-down operations may only be carried out by personnel qualified to operate the affected equipment.

The employee or contractor who reports the spill, must, depending on circumstances, be present at the site, or available by cell phone or radio, when the Spill Coordinator arrives on scene. All operating personnel have been trained on spill containment techniques, and the deployment of spill response equipment and materials to provide initial spill response and management until the Spill Coordinator arrives.

Table 1 – Oil Spill Response Procedures

Spill Discovery and Initial Response	<ol style="list-style-type: none"> 1. If no immediate threat to safety is present and the source of the release is still present; stop the source of the release using the Equipment Shutdown Procedures detailed in Table 2 and call the Encana Gas Control number (970.285.2615) 2. Contain the release using available materials and methods. Including berms, dykes, and spill kit materials. 3. Restrict ignition sources if the material is flammable. 4. Secure the area as off limits. 5. In the event that the spill poses an <u>immediate threat</u> of fire, explosion, or other imminent threat to public safety; call local emergency response (911). DO NOT HANG UP after completing the report, let the dispatcher hang up first. 6. Report the spill to the Environmental 24hr On-Call Number (970.319.9173). The on-call member of the Environmental Compliance Group is the Spill Coordinator. Be prepared to provide the following information.
Information to Provide During Initial Report to Environmental On-Call	<ol style="list-style-type: none"> 7. Has the spill reached, or does it threaten to reach, waters of the state? 8. Where is the spill (nearest pad/facility and field)? Be prepared to provide directions. 9. Which personnel were present at the time of the spill? 10. What activities caused the spill? 11. When did the spill occur? 12. What is the material spilled? 13. What volume has spilled?
Spill Containment, Clean Up, and Reporting	<ol style="list-style-type: none"> 14. The employee or contractor who reports the spill, must, depending on circumstances, be present at the site, or available by cell phone, when the Spill Coordinator arrives on scene. 15. The Spill Coordinator will notify Encana management of the spill and may mobilize response resources based on the scope described in the initial report. 16. The Spill Coordinator will travel to the incident location and conduct a comprehensive assessment of the spill, and coordinate clean up efforts. 17. If necessary, a follow up report to Encana management, and verbal notification of government and municipal agencies and other appropriate entities will be made. 18. Should additional remediation efforts be necessary, the Spill Coordinator will contact one of Encana’s designated spill remediation contractors. 19. If the spill is determined to be of a reportable quantity or character, the Spill Coordinator will complete required verbal notifications and submit appropriate written notifications and reports to appropriate agencies as outlined below in notification procedures. 20. The Spill Coordinator will enter the incident into Encana’s Incident Management System, and identify appropriate follow up activities and/or corrective actions.

Table 2 – Equipment Shutdown Procedures

Source	Action
Manifold, transfer pumps or hose failure	Have a qualified person shut in the well supplying oil to the tank battery if appropriate. Immediately close the header/manifold or appropriate valve(s). Shut off transfer pumps.
Tank or pond overflow	Have a qualified person shut in the well supplying oil to the tank battery. Close header/manifold or appropriate valve(s).
Tank failure	Have a qualified person shut in the well supplying oil to the tank battery. Close inlet valve to the storage tanks.
Flowline rupture	Have a qualified person shut in the well supplying oil to the flowline. Close nearest valve to the rupture site to stop the flow of oil.
Flowline leak	Have a qualified person shut in the well supplying oil to the flowline. Immediately close the nearest valve to stop the flow of oil to the leaking section.
Explosion or fire	Immediately evacuate personnel from the area and secure the area from entry by the public or other personnel. Have a qualified person immediately shut in all wells if safe to do so. If possible, close all manifold valves. If the fire is small enough such that it is safe to do so, attempt to extinguish with available fire extinguishers.
Equipment failure	Have a qualified person immediately close the nearest valve to stop the flow of oil into the leaking area.

OIL SPILL REGULATORY NOTIFICATION PROCEDURES

This section provides reportable quantities for exploration and production (E&P) waste.

In the event of a release, government agencies may need to be notified. *All verbal and written notifications are to be made by the Environmental Compliance Group or designate(s).* As a practical matter, an evaluation of the specifics of each spill and a determination of reporting requirements will be made. If there is any question about reporting, Encana will over-report rather than under-report.

Table 3 provides an overview of reporting requirements, procedures, and contact information for Encana departments and relevant government agencies.

Verbal Notifications to Government Agencies

Encana's policy is to report all **spills on public lands** administered by the Bureau of Land Management (BLM) or US Forest Service (USFS) to the affected agency as soon as practicable.

If a release has reached, or has the potential to reach, **waters of the state**, or a municipal drain or storm sewer; verbal notifications must be made as soon as possible to Local Emergency Response (911), the National Response Center (NRC) Hotline, Colorado State Patrol, Local Emergency Planning Commission (LEPC), Colorado Oil and Gas Conservation Commission (COGCC), Colorado Department of Public Health and Environment (CDPHE) - Colorado Water Quality Control Division, and any potentially affected landowner, municipal water company, or sewer authority and wastewater treatment plant.

In the event of a spill/release which may **threaten a residence, occupied structure, livestock, or public right-of-way**; verbal notifications must be made as soon as practicable to Local Emergency Response (911), the COGCC, CDPHE, and any potentially affected landowner.

In addition, the COGCC further requires verbal notification within 24 hours for spills/releases of exploration and production (E&P) waste which exceed 20 barrels.

Information to Provide During Verbal Notifications

When notifying a government agency of a release, the following information should be gathered as soon as possible and provided as necessary:

1. Name and location of the facility. Be prepared to provide directions to the scene.
2. Specific location where the discharge occurred.
3. Your name, position, and telephone number.
4. Name and address of the owner/operator
5. Date and time of the discharge.
6. Information on the discharge:
 - Type of material discharged (e.g., diesel),
 - Source of discharge (e.g., aboveground storage tank),
 - Estimated total quantity discharged, including the estimated total quantity discharged to navigable waters or adjoining shorelines,
 - Danger or threat posed by the release / discharge,
 - Weather conditions,
 - Cause of discharge,
 - Affected media (e.g., soil, surface water), and area of impact,
 - Damages or injuries caused by the discharge,
 - Response actions being used to stop, contain, mitigate, or clean-up the discharge,
 - Time to contain the discharge,
 - Whether the discharge has been stopped, and
 - Whether an evacuation may be needed.
7. Names of other individuals or agencies that were contacted.
8. Other Information that may help emergency personnel prepare for, and respond to the incident.
9. Names and titles of government agency personnel who have reported to the scene.

Record the following information when making a notification:

- Name and position of person contacted.
- Agency contacted.
- Date and time of notification.
- Information provided to agency.

Written Notifications to Government Agencies

If a verbal notification has been made under any of the conditions provided above; a follow up written report will be submitted to the notified agency, following the guidelines provided in Table 3. Written reports will be made utilizing the agencies own reporting formats, when available. When a standard format is not provided by the agency being reported to; Encana will provide a report with the information mandated by the Environmental Protection Agency's (EPA) spill reporting requirements.

In addition to follow up reports to verbal notifications, the Colorado Oil and Gas Conservation Commission (COGCC) requires written reports for spilled quantities less than those mandating verbal notifications. Those reporting requirements are detailed in COGCC Rule 906, and in the following section.

State Agencies

All spills and releases of E&P waste exceeding 5 barrels, including those contained within secondary containment, shall be reported in writing, within 10 days, to the COGCC using the Spill/Release Report (Form 19). Completed reports will be emailed to the appropriate COGCC regional representative or sent to the address provided in Table 3.

All spills and releases of hazardous materials which exceed the Reportable Quantity (RQ) identified by CERCLA (Comprehensive Environmental Response, Compensation, and Liability Act) will be reported to the National Response Center (NRC) and CDPHE Hazardous Materials and Waste Management Division.

Federal Agencies

In accordance with 40 CFR 112.4(a) a spill report will be submitted to the U.S. Environmental Protection Agency (EPA) Region 8 Administrator if either of the following conditions is met:

- A single discharge, into or upon navigable waters of the United States, of more than 1,000 gallons of oil, or
- A discharge, into or upon navigable waters of the United States, of more than 42 gallons of oil in each of two events within any 12 month period.

The spill report to the EPA must be submitted ***within 60 days of the release*** and contain the following information:

1. Name of the facility.
2. Name of the owner/operator of the facility.
3. Location of the facility.
4. Maximum storage or handling capacity of the facility and normal daily throughput.
5. Corrective actions and countermeasures taken, including a description of equipment repairs and replacements.
6. An adequate description of the facility, including maps, flow diagrams, and topographic maps, as necessary.
7. The cause of the discharge, including a failure analysis of the system or subsystem in which the failure occurred.
8. Additional preventive measures taken or contemplated to minimize the possibility of recurrence.
9. Such other information as the U.S. EPA Regional Administrator may reasonably require pertinent to the SPCC Plan or discharge.

A copy of the above information also must be submitted to the Colorado Department of Public Health and Environment (CDPHE) in accordance with 40 CFR 112.4(c). Contact information is provided in Table 3.

CONTACT INFORMATION AND NOTIFICATION PROCEDURES

Operating personnel must immediately report all spills to Encana’s 24-Hour Environmental On-Call Phone. Encana’s Environmental Compliance Group (ECG) will determine the appropriate level of response, notify the Authorized Facility Representative, and if necessary, contact appropriate government agencies and assist in mobilizing resources.

Environmental On-Call (24 hours)	970.319.9173
Safety On-Call (24 hours)	970.210.8755
Gas Control (24 hours)	970.285.2615
Public Relations / Land Department On-Call (24 hours)	970.285.2777
David Grisso – Authorized Facility Representative	970.285.2601
Local Emergency (fire, explosion, or other hazards)	911

Table 3 – Notification Procedures and Contact Information

Agency / Organization	Agency Contact	Circumstances	When to Notify
<i>Federal Agencies</i>			
National Response Center (NRC)	800.424.8802	Discharge reaching waters of the state, or a municipal drain or storm sewer, or of releases of hazardous materials in excess of the Reportable Quantity (RQ)	Immediately (verbal)
EPA Region VIII (Hotline)	800.227.8914	Discharge reaching waters of the state, or a municipal drain or storm sewer.	Immediately (verbal)
EPA Region VIII Regional Administrator	999 18 th Street, Suite 500 Denver, CO 80202-2466 r8eisc@epa.gov	Follow up report to verbal notification. Discharge, into or upon navigable waters of the United States, 1,000 gallons or more; or 2 discharges of 42 gallons or more within a 12-month period.	Written notification within 60 days (see the related discussion above)
Bureau of Land Management (BLM)	970.244.3000 (Grand Junction Field Office - GJFO) 970.947.5200 (Glenwood Springs Energy Office - GSEO) 970.878.3800 (White River Field Office – WRFO)	<i>Major Undesirable Events</i> Discharges on BLM/USFS lands: <ul style="list-style-type: none"> • > 100 BBL of liquids, • > 500 MCF gas, and/or • any release in a sensitive area (parks, rec. areas, refuges, water bodies...) 	Immediately (verbal)

Agency / Organization	Agency Contact	Circumstances	When to Notify
BLM	<p>GJFO 2815 H Road Grand Junction, CO 81506</p> <p>GSEO 2425 S. Grand Avenue, Suite 101 Glenwood Springs, CO 81601</p> <p>WRFO 220 E. Market Street Meeker, CO 81641</p>	<p><u>Major Undesirable Events</u> and <u>Other-Than-Major Undesirable Events</u></p> <ul style="list-style-type: none"> • following any verbal notification, or • Discharges on BLM/USFS lands: <ul style="list-style-type: none"> ◦ > 10 BBL of liquids, or ◦ > 50 MCF of gas. 	File an "Undesirable Event Form" with appropriate personnel at the affected Field Office.
BLM	<p>GJFO 2815 H Road Grand Junction, CO 81506</p> <p>GSEO 2425 S. Grand Avenue, Suite 101 Glenwood Springs, CO 81601</p> <p>WRFO 220 E. Market Street Meeker, CO 81641</p>	Spills or discharges in nonsensitive areas involving less than 10 BBL of liquid or 50 MCF of gas.	Volume and value of losses must be reported on the "Oil and Gas Operations Report" and on the "Report of Sales and Royalty Remittance".

Agency / Organization	Agency Contact	Circumstances	When to Notify
<i>State Agencies</i>			
Colorado Oil and Gas Conservation Commission (COGCC)	<p><u>Environmental Release / Incident Report Hotline</u> 877.518.5608</p> <p>and</p> <p><u>Chris Canfield</u> 970.625.2497 (office) 970.216.6832 (cell)</p> <p>or</p> <p><u>Linda Spry O'Rourke</u> 970.625.2497 (office) 970.309.3356 (cell)</p>	Discharge which reaches or threatens to reach waters of the state, a municipal drain or storm sewer, or any surface water supply area or intake (317B). Or which impacts or threatens to impact a residence/occupied structure, livestock, or public byway.	Immediately (verbal)
COGCC	<p><u>Chris Canfield</u> 970.625.2497 (office) 970.216.6832 (cell)</p> <p>or</p> <p><u>Alex Fischer</u> 303.8942100 (office)</p>	Discharges of >20 bbls of Exploration and Production (E&P) waste, or >25 gallons of refined hydrocarbons.	Within 24 hours.
COGCC	<p><u>Chris Canfield</u> Chris.Canfield@state.co.us</p> <p>or</p> <p><u>Alex Fischer</u> Alex.Fischer@state.co.us</p>	Any discharge or release of E&P waste exceeding 5 bbls	Written notification within 10 days using Spill/Release Report (Form 19)

Agency / Organization	Agency Contact	Circumstances	When to Notify
CDPHE 24Hour Emergency Spill/Release Reporting Hotline	877.424.8802	Any discharge of hazardous materials in excess of the reportable quantity (RQ), or any amount reaching waters of US, or a municipal drain or storm sewer.	Verbal or written within 24 hours
CDPHE	4300 Cherry Creek Drive South Denver, CO 80246-1530	Follow up to verbal notification. Discharge limits identified by the EPA.	Submit duplicates of any report submitted to the EPA.
Colorado State Patrol (CSP)	303.239.4501	Discharge reaching waters of the state, or a municipal drain or storm sewer, or directly affecting a public byway.	Immediately (verbal)
<i>Local Agencies</i>			
Emergency Response	911	Discharge reaching waters of the state, or a municipal drain or storm sewer. If there is an immediate threat to the safety of the public or operating personnel	Immediately (verbal)
Mesa County Emergency Planning Committee (LEPC)	Horace Sessions 970.245.8148 horace_sessions@sartomer.com PO Box 2242 Grand Junction, CO 81502	Discharge reaching waters of the state, or a municipal drain or storm sewer in Mesa County.	Immediately (verbal) Written follow up within 7 days.
Garfield County Emergency Planning Committee (LEPC)	Chris Bornholdt 970.945.8020 cbornholdt@garfield-county.com 109 8 th Street, Suite 300 Glenwood Springs, CO 81601	Discharge reaching waters of the state, or a municipal drain or storm sewer in Garfield County.	Immediately (verbal) Written follow up within 7 days.
Rio Blanco County Emergency Planning Committee (LEPC)	John Hutchins 970.878.5023 jhutchins@co.rio-blanco.co.us PO Box 647 Meeker, CO 81641	Discharge reaching waters of the state, or a municipal drain or storm sewer in Rio Blanco County.	Immediately (verbal) Written follow up within 7 days.
<i>Public Water Intakes / Surface Water Supply Areas</i>			
Parachute Public Works (Parachute Creek & Colorado River)	<u>Emergency – 24 hr.</u> 970.285.7630 Mark King or 970.285.7630 Bill Rose PO Box 100 Parachute, CO 81635	Discharge which impacts or threatens to impact any surface water supply intake (317B) in the Parachute Surface Water Supply Area.	Immediately (verbal)
Rifle Public Works (Beaver Creek & Colorado River)	<u>Emergency – 24 hr.</u> 970.309.8548 Charlie Stevens or 970.379.6162 John Stewart 202 Railroad Ave. Rifle, CO 81650	Discharge which impacts or threatens to impact any surface water supply intake (317B) in the Rifle Surface Water Supply Area.	Immediately (verbal)

Agency / Organization	Agency Contact	Circumstances	When to Notify
Parachute Creek/ Colorado River	<u>Emergency – 24 hr.</u> 970.464.5563 Water Treatment Plant 560 25 Road Grand Junction, CO 81505	Discharge which impacts or threatens to impact any surface water supply intake (317B) in the Colorado Surface Water Supply Area.	Immediately (verbal)
De Beque Public Water - Colorado River	<u>Emergency – 24 hr.</u> 970.250.8468 Coe Latham or 970.216.4885 Isaac Inskeep 381 Minster Ave. PO Box 60 De Beque, CO 81630	Discharge which impacts or threatens to impact any surface water supply intake (317B) in the De Beque Surface Water Supply Area.	Immediately (verbal)
Piceance Creek/ White River	<u>Emergency – 24 hr.</u> 970.675.2221 Water Treatment Plant 209 East Main Street Rangely, CO 81648	Discharge which impacts or threatens to impact any surface water supply intake (317B) in the White River Surface Water Supply Area.	Immediately (verbal)
Ute Water / Coon Creek & Parachute Creek	<u>Emergency – 24 hr.</u> 970.242.7491 Office Answering Service or 970.270.3910 Steve Ryker or 970.464.5563 Water Treatment Plant 560 25 Road Grand Junction, CO 81505	Discharge which impacts or threatens to impact any surface water supply intake (317B) in the Plateau Surface Water Supply Area.	Immediately (verbal)
<i>Others</i>			
In the event that a discharge requires notification of landowners, The Spill Coordinator will contact Encana's Community Relations On-Call Phone (970.285.2777) to make those notifications.			

Table 4 – Contractor Contact Information

Contractors	
Water Hauler Resources – Coordinate with Pumper or Facility Operator for first available.	
Knowles Enterprises, LLC	970.434.1912
Arrested Oil Field Services, Inc.	970.371.4164 970.539.5266
Arnett Trucking LLC	970.878.5015
Big H Water Service, Inc.	970.309.8162
Summit Trucking	970.361.1730
Trinity Water Services, Inc.	970.985.0510

Contractors	
Beaver Creek Water Hauling	970.618.9735
Earth Work / Excavation Resources	
Tamarrel Excavation	970.379.5780
Moody & Sons Excavation	970.379.5121
Roustabout Resources	
WCO	970.556.0885
Advanced Oil Field Services	970.625.9704
Water Pumping Resources	
Western Pump and Dredge, Inc.	970.244.9097
Rain for Rent	800.742.7246
Environmental Consulting Resources	
Rule Engineering	970.244.8500 (office)
LT Environmental	970.285.9985 (On-Call/Office)

Table 5 – Additional Government Agency Contact Information

Colorado Oil and Gas Conservation Commission (COGCC)	303.894.2100
COGCC 24-Hour Hotline	303.860.1435
Division of Oil and Public Safety (Dept. of Labor and Employment)	303.318.8547
Colorado State Patrol Hazmat Service	970.242.7283
St. Mary's Hospital – Grand Junction	970.244.2273
Grand River Medical Center - Rifle	970.625.1510
Mesa County Sheriff	970.244.3200
Garfield County Sheriff	970.945.0453

Table 6 – Additional Encana Personnel Contact Information

Scott Parker – Field Construction Leader	970.285.2787 (office) 970.379.9798 (cell)
Gerald Papez – Production Coordinator	970.260.8966 (cell)
Ross Deters – Automation Coordinator	970.285.2725 (office) 970.309.8580 (cell)
Cindy Allen – Group Lead, EHS South Rockies	720.876.5030 (office) 303.819.7323 (cell)
Chris Durrant – Water Systems Engineer	720.876.5762 (office) 303.895.0748 (cell)
Brad Ankrum – Midstream Field Operations Leader	970.285.2630 (office) 435.260.1673 (cell)
Rocky Erb – Field Operations Coordinator (East of Parachute)	970.285.2639 (office) 970.210.8571 (cell)
Kathy Friesen – Environmental Field Lead	970.285.2665 (office) 970.319.2270 (cell)
Brett Middleton – EHS Field Coordinator (Spill Response)	970.285.2739 (office)

	970.987.4650 (cell)
Chris Hines – EHS Field Coordinator (SPCC/Spill Response)	970.285.2653 (office) 970.261.1127 (cell)
Kathy Vertiz – Surface Management Coordinator	970.285.2626 (office) 970.456.6406 (cell)
Brad Mallory – EHS Safety Lead	970.285.2699 (office) 970.309.1193 (cell)
Dan Prokop – EHS Field Coordinator (Spill Response)	970.285.2707 (office) 815.790.5907 (cell)
Charles Jensen – EHS Field Coordinator (SPCC / Spill Response)	970.285.2735 (office) 970.309.1022 (cell)

RESOURCES, EQUIPMENT, AND SUPPLIES FOR OIL SPILL RESPONSE

As part of the OSCP, Encana has committed the necessary resources to address and mitigate any spill or discharge of oil. The resources available include the following:

- Procedures – Encana personnel are required to immediately report all spills to the Environmental On-Call Phone (970.319.9173).
- Personnel – The Spill Coordinator is the qualified person from the Environmental Compliance Group (ECG) responsible for the Environmental On-Call Phone at the time of an incident. The Environmental On-Call Phone is a 24-hour “hotline” for receiving calls regarding any spill, or environmental incident that occurs within the South Parachute/South Piceance areas. In addition, Encana provides additional resources (other personnel, specialized contractors, etc.) necessary to mitigate any spill.
- Equipment – Personal Protective Equipment (PPE) - Encana supplies the appropriate PPE to don while in the field. The standard PPE includes a hard hat, steel toed boots, fire or flame resistant coveralls/clothing, and safety glasses. Additional PPE is provided based on the level of hazards anticipated.
- Equipment – Spill Drums and Environmental Response Trailer(s) – Encana supplies and inventories spill drums (kits) and response trailers to assist in the mitigation of a spill. The spill drums are typically 95-gallon immediate response spill kits. The trailers may have spill drum(s) and additional supplies for larger spills. Appendix B has a detail inventory list of the spill drums and trailers. Figure 1 shows the locations of the spill drums/trailer(s) for the Benzel WTF.
- Training – All Encana field personnel are required to complete environmental, health and safety training, including SPCC awareness, and spill response and reporting. Training records are kept on file in the Parachute Field Office.

INCIDENT TERMINATION

Once a release has been contained and cleaned-up, recorded in Encana’s Incident Management System (IMS), and any required verbal and written notifications have been made, the Spill Coordinator will take the following actions:

1. If the spill was a reportable release, into or upon navigable waters of the United States, prepare a spill report and file it with the SPCC Plan.
2. If necessary, verify that spill equipment has been re-stocked.
3. Verify that the spilled oil is properly containerized, labeled, and stored for disposal.

Review the cause and response to the release with supervisors, witnesses, and contractors, if appropriate. Determine additional requirements necessary to prevent recurrence of the incident, and discuss those measures with facility personnel during regularly scheduled briefings and trainings. Amend the SPCC Plan if necessary.

Appendix A

Spill Trailer Inventory Spill Drum Kit Inventory

Appendix B

References

	SPILL AND ENVIRONMENTAL RELEASE REPORTING PRACTICE	Document No: E-005
		Revised By/Date: FGC 2/11/2010
		Reviewed By/Date: FGC 2/11/2010
		Approved By/Date: J. Thatcher/ 2/28/2010

I. Spills Required to be Reported in IMS

EnCana Oil & Gas (USA) Inc. (EnCana) employees and non-EnCana employees who work under contract for EnCana shall report into IMS any spill or environmental release¹ caused for any reason (including contractor or third-party actions) at EnCana operations. Spills that meet the following description must be reported into IMS:

A **spill** is any unpermitted quantity of liquid or solid substance that is partially or wholly outside of its primary containment (e.g., tank, drum, truck, pond, pit, storage sack, rig trench), excluding beverages, food items, and potable water².

A. Purpose for Reporting

EnCana strives to operate our facilities in a prudent and environmentally responsible manner. Consistent spill reporting allows us to measure and minimize our impact on the environment. EnCana uses the criteria in Section I.A of this guidance for reporting of spills, in order to:

- Ensure that the environment is protected by:
 - Reducing the overall number of spills,
 - Identifying areas or trends where controls should be implemented, and
 - Encouraging controls to be established to mitigate any environmental impact of spills;
- Foster a culture of active spill mitigation;
- Standardize the reporting process across the Division; and
- Make a clear and concise definition that is easy to apply.³

B. Applicability to Drilling and Completion Activities

Drilling and completion activities must follow the above criteria in reporting spills. Upon discovery of a spill, EnCana employees and non-employees must identify the source of the spill, act to prevent any further spillage or impacts to the environment, and immediately remediate or clean up the soil or surface impacted by the spill. These actions must be taken with consideration to safety.

C. Applicability to Transportation

Spills that occur related to transportation activities at EnCana operations are required to be reported into IMS. If a spill occurs during the loading of the produced water, it must be reported into IMS. If the spill occurs outside of the physical EnCana operation after the material being transported has left EnCana's

¹An **environmental release** is an emission or spill that is either:

- Outside (in any manner) of impervious engineered controls (e.g., drip pans, pop-up pools, lined tank ring); or
- Has an impact (e.g., air, soil, groundwater, surface water, or wildlife) to the natural environment.

Gaseous environmental releases are to be reported in IMS under the sub category of 'gaseous substance'. For IMS purposes, spills are considered an environmental release only if outside of secondary containment (with direct effect on water or land) or have an effect on wildlife or air.

² Regardless of secondary containment, some states require reporting of large quantity spills. See Appendices for specific details.

³ Unpermitted gaseous releases are not required to be recorded as a spill. Data related to gaseous emissions may be recorded in other existing databases. Unpermitted gaseous releases may be required to be reported to a regulatory agency pursuant to a permit, regulation, or law.

custody, it is still required to be reported to IMS, unless the hauler is contractually obligated to take ownership of the material. Leaks generated by equipment associated with the transportation of the material during transport are not required to be reported into IMS and is the responsibility of the transporter (i.e., if there is a leak from a gas tank or radiator that is the responsibility of the transport company).

II. Reporting Spills to Agencies

The requirement to report spills into IMS is equivalent to or more stringent than local, state and federal requirements. Reporting requirements to local, state and federal agencies for each jurisdiction where EnCana operates is included in Appendices A through C in this guidance.

III. Primary Containment

The following are examples of equipment that are considered primary containment for purposes of this spill reporting guidance:

- Storage: tanks, drums, totes, authorized pits, and storage sacks;
- Transportation: trucks and pipelines; and
- Process Equipment: separators, dehydrators, heater treaters, gun barrels, and water treatment facilities.

IV. Engineered Controls

Engineered controls must be impervious in order to prevent potential impacts to state and federal waters. The following are examples of equipment and technologies that are considered engineered controls for purposes of this spill reporting guidance:

- Steel, plastic, or fiberglass containment tubs;
- Stock tanks;
- Poly-lined metal containment dikes;
- Drip pans, bucket and basin;
- Inflatable and rubber truck containment;
- Containment pallets;
- Buildings with built in containment skids;
- Concrete unload areas with trenching to sump;
- Pop-up pools;
- Lined tank rings; and
- A system by which a volume of liquid can be held for an indefinite amount of time without any loss of volume to the surrounding environment (excluding evaporation).

The following are examples of equipment and technology that are not considered engineered controls:

- Earthen or gravel berms; and
- Controls that are full of water or accumulated leaks such that the actual containment is compromised.

V. Examples of Reportable and Non-Reportable Spills

The following are examples of spills that must be reported in IMS.

- If at a drilling operation, a spill of water-based drilling mud has occurred and is still contained within the drill pad, it must still be reported to IMS.
- If an engineered control does not adequately prevent pollutants from escaping the equipment or technology to the natural environment, then the incident must be reported as a spill. For example, a spill has occurred if an engineered control is full of rain water and polluted water overflows from the engineered control.

The following are examples of events that do not need to be reported in IMS.

- Stained soil does not need to be reported if there is not an identifiable source of the materials and it is cleaned up within 24 hours of the discovery of the stain. If a source of the stain can be identified, the employee or contractor should treat it as a spill.

VI. Spill Reporting Procedures

Spills shall be reported and responded to consistently with EnCana's "Reporting Guide for Environment, Safety, and Security Incidents" (<http://ecn.encana.com/ehs/Corporate/docs/Reporting%20Guide.pdf>) and applicable Emergency Response Plans for the affected facility. In Appendix D are detailed procedures for different roles (EH&S coordinator, manager, pumper) of where and how to capture spill information and timeline for reporting; definitions of responsibilities and accountabilities for spill reporting; and how to manage cumulative events like repeated drips, or continuing leaks inside earthen containment.

VII. Effective Use of Spill Information

EnCana will regularly review information reported into IMS in order to:

- Identify and examine common occurrences to determine if procedural or mechanical changes need to occur to reduce the number and size of spills;
- Trend operational performance;
- Encourage transparency and goodwill with stakeholders;
- Recognize EnCana employees and non-employees that appropriately report and respond to spills; and
- Increase EnCana's knowledge in order to improve environmental performance, reduce risks and minimize liability related to spills.

Appendices

Appendix A	A.1 Regulatorily Required Spill Reporting Matrices for Mid-Continent Business Unit A.2 MCBU Incident Reporting Matrix A.3 MCBU Regulatory Links
Appendix B	B.1 Regulatorily Required Spill Reporting Matrices for North Rockies Business Unit B.2 NRBU Spill Reporting Guideline and Table B.3 NRBU Regulatory Links B.4 NRBU Definition and Notification of Spill or Leak
Appendix C	C.1 Regulatorily Required Spill Reporting Matrices for South Rockies Business Unit C.2 Spill Reporting Flow Chart – DJ Basin, Piceance, Paradox, Colorado C.3 Spill Reporting Flow Chart – Paradox-Utah C.4 Spill Reporting Flow Chart – South and West Texas C.5 SRBU Regulatory Links
Appendix D	Roles and Responsibilities in Spill Incidents
Appendix E	Frequently Asked Questions
Appendix F	Calculations for 40 CFR 302.4 Reportable Quantities

APPENDIX A.1

**REGULATORILY REQUIRED SPILL REPORTING
MATRICES FOR MID-CONTINENT BUSINESS UNIT**

Note: The use of these Spill Reporting Documents does not preclude the use and importance of each field's Emergency Management Plan.

Spill Reporting Documents (matrices/flowcharts) are updated by BU EH&S personnel on a monthly basis and all potential spill response personnel and other affected personnel are notified if an actual change is made to the document or the location of the document is changed.

APPENDIX A.2

MCBU INCIDENT REPORTING MATIRX

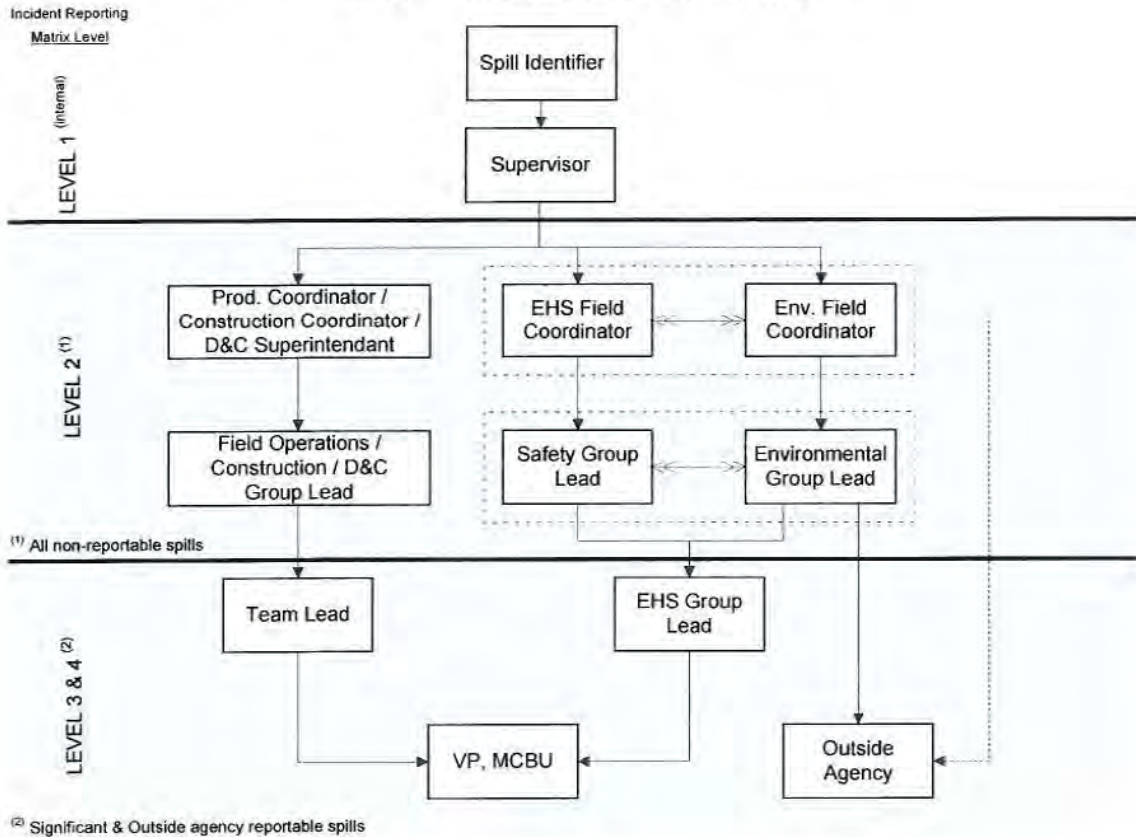

Report to an Outside Agency?

First Report Spill Internally

Prod. Fluid or Haz. Substance exceed RQ?

Yes

Determine agency to contact.

Production Fluids	Texas	Louisiana
Reportable Quantity (RQ)		
Oil	≥ 5 bbl	≥ 1 bbl
Produced Water	Only if waters of US affected	≥ 1 bbl
Natural Gas	H2S ≥ 100 lb (2110 scf @ 100% H2S)	1 MMscf
VOC (C ₃ +)	≥ 5000 lb	≥ 5000 lb

Select Hazardous Substances	Texas or Louisiana	
	Land	Navigable Water
Reportable Quantity (RQ)		
Ethylene Glycol (EG)	5,000 lb (1,000 gal)	100 lb (20 gal)
Mercury	0.06 lb (1 oz)	0.06 lb (1 oz)
Methanol	5,000 lb (780 gal)	100 lb (15 gal)
TEG	5,000 lb (1,000 gal)	100 lb (20 gal)
Barium	100 lb	100 lb
Hydrochloric Acid (HCl)	5000 lb	100 lb

Outside Agency Reportable	Texas	Louisiana
Incident type		
Produced water or Oil released greater than RQ	RRC	State Police* LDEQ
Near or in environmentally sensitive area or	RRC TCEQ	State Police* LDEQ
Navigable water release or Hazardous Substance vol. greater than RQ	RRC TCEQ NRC	State Police* LDEQ NRC

* Report within 60 min. of event, if possible

APPENDIX A.3

MCBU REGULATORY LINKS

Texas Regulatory Links

Field Guide for the Assessment and Cleanup of Soil and Groundwater Contaminated with Condensate from a Spill Incident

<http://www.rrc.state.tx.us/environmental/spills/spillcleanup.php>

Texas Railroad Commission Cleanup of Soil Contaminated by a Crude Oil Spill

[http://info.sos.state.tx.us/pls/pub/readtac\\$ext.TacPage?sl=R&app=9&p_dir=&p_rloc=&p_tloc=&p_ploc=&pg=1&p_tac=&ti=16&pt=1&ch=3&rl=91](http://info.sos.state.tx.us/pls/pub/readtac$ext.TacPage?sl=R&app=9&p_dir=&p_rloc=&p_tloc=&p_ploc=&pg=1&p_tac=&ti=16&pt=1&ch=3&rl=91)

Field Guide for Reportable Surface Releases of Crude Oil in Non-Sensitive Areas

<http://www.rrc.state.tx.us/environmental/spills/spillincident.php>

Louisiana Regulatory Links

Louisiana Oil Spill Coordinators Office

<http://www.losco.state.la.us/>

Louisiana Oil Spill Prevention and Response Act of 1991 (amended)

http://www.losco.state.la.us/pdf_docs/OSPRA_2003.pdf

State Spill Notification Regulations

http://www.losco.state.la.us/pdf_docs/State%20Spill%20Notification%20Regulations_Title%2033.pdf

All Louisiana Acts, Regulations, Guidelines, and Plans

<http://www.losco.state.la.us/regulations.htm>

APPENDIX B.1

**REGULATORILY REQUIRED SPILL REPORTING
MATRICES FOR NORTH ROCKIES BUSINESS UNIT**

Note: The use of these Spill Reporting Documents does not preclude the use and importance of each field's Emergency Management Plan

Spill Reporting Documents (matrices/flowcharts) are to be updated by BU EH&S personnel on a monthly basis and all potential spill response or affected personnel notified if an actual change is made to the document or its location is changed.

APPENDIX B.2

NRBU SPILL REPORTING GUIDELINE AND TABLE

The following guidance is to be used by NRBU locations for internal and external reporting of spills.

There are two general classifications of spills:

- Spills required to be reported internal to EnCana via the Incident Management System (IMS)
- Spills required to be reported to regulatory agencies

Internal Reporting

EnCana is using the IMS as a tool to track and trend spills and their causes so systemic problems can be realized and preventative measures can be determined. Tracking of spills and their causes is important not only because of environmental concerns, but also for loss prevention.

External Reporting

Individual agencies have different reporting requirements, although some spills may need to be reported to more than one agency.

Reporting requirements are summarized in the table below and the actual regulations are included later in this guidance.

For Wyoming, agencies that may need to be notified based on the criteria outlined in the table include:

- Wyoming Department of Environmental Quality (WDEQ)
- Wyoming Oil and Gas Conservation Commission (WOGCC)
- Bureau of Land Management (BLM) for spills occurring on federal leases
- United States Environmental Protection Agency (USEPA)

Wyoming Department of Environmental Quality

The Wyoming DEQ spill reporting information is available on the following web page:

<http://deq.state.wy.us/out/spills.htm>

This website also contains

- spill reporting forms that can be downloaded
- a list of contractors providing emergency response services.
- Phone number of emergency response coordinator for questions on what needs to be reported
307-777-5885

****Interpretation from DEQ: Regardless of containment, report any spill quantity of produced water or condensate over 10 barrels or 25 gallons of other manufactured or refined material.**

Wyoming Oil and Gas Conservation Commission

The WOGCC rules for spill reporting are currently undergoing revision and are expected to be more stringent.

The spill reporting requirements for the Wyoming Oil and Gas Conservation Commission Rules Chapter 4 Environmental Rules, Including Underground Injection Control Program Rules For Enhanced Recovery And Disposal Projects, Section 3 Accidents, Spills and Fires

Chapter 4, Section 3 (B) states - Uncontained spills or unauthorized releases of produced fluids, drilling muds, produced water, hydrocarbons, or chemicals **which enter, or threaten to enter, waters of the state** must be verbally reported to the Commission no later than the next business day following discovery of the incident. Spills of less than ten (10) barrels (420 gallons) of crude oil, petroleum condensate, produced water, or a combination thereof which occur on a lease, unit, or communitized area and do not physically enter waters of the state and are immediately contained, removed, and disposed of properly are not required to be reported. The owner or operator shall file a written report within fifteen (15) working days. An example of the information normally required by the Commission for reporting spills is included in Appendix E. The Commission accepts copies of reports prepared to satisfy the requirements of the Department of Environmental Quality or the Bureau of Land Management.

<http://wogcc.state.wy.us/craig/spill.htm>

APPENDIX B.2

NRBU SPILL REPORTING GUIDELINE AND TABLE

Bureau of Land Management

The BLM spill reporting requirements are stated in Notice to Lessees document NTLA-3A, Reporting of Undesirable Events. This document can be found at:

http://www.blm.gov/wy/st/en/programs/energy/Oil_and_Gas/docs/ntl_3a.html

Notify BLM verbally immediately on Federal leases: oil, produced water, or toxic liquid exceeding 100 bbls or any spill which occurs in a sensitive area. Written report within 15 days.

Written report to District Engineer for spills or oil, produced water, or toxic liquid that exceed 10 bbls, but less than 100 (non-sensitive) on a frequent bases (contained or uncontained).

US Environmental Protection Agency

The USEPA requires reporting for oil spills and hazardous substance releases to land, air, or water.

Oil Releases

Oils spills that require reporting are defined in 40 CFR 110.3 and reporting requirements are in 40 CFR 110.6

§110.3 Discharge of oil in such quantities as "may be harmful" pursuant to section 311(b)(4) of the Act.

For purposes of section 311(b)(4) of the Act, discharges of oil in such quantities that the Administrator has determined may be harmful to the public health or welfare or the environment of the United States include discharges of oil that:

(a) Violate applicable water quality standards; or

(b) Cause a film or sheen upon or discoloration of the surface of the water or adjoining shorelines or cause a sludge or emulsion to be deposited beneath the surface of the water or upon adjoining shorelines. [61 FR 7421, Feb. 28, 1996]

<http://law.justia.com/us/cfr/title40/40-21.0.1.1.6.0.6.3.html>

§110.6 Notice

Any person in charge of a vessel or of an onshore or offshore facility shall, as soon as he or she has knowledge of any discharge of oil from such vessel or facility in violation of section 311(b)(3) of the Act, immediately notify the National Response Center (NRC) (800-424-8802).

Hazardous Substances

Hazardous Substances and their Reportable Quantities (RQs) are in 40 CFR Table 304.2. RQ's vary by chemical and the list is too extensive to provide here. Reports are made based on individual chemicals not the mixture within a certain product. Therefore, to determine if an RQ has been exceeded, it is necessary to calculate the amount of material that would have to be released to exceed the reportable quantity for any of its constituents. RQs are given in pounds so for liquids, a conversion from pounds to gallons will need to be made, taking into account the specific gravity or specific density of the material.

The calculation to determine RQ for a specific material with hazardous substance constituents is as follows:

$$\text{Amt. of material exceeding RQ (gals)} = \frac{\text{Chemical specific RQ (lbs)}}{\text{Density of material (lb/gal)} \times \text{Amt of haz. constituent (wt.%)}}$$

The following table lists the calculated RQs for several materials used in EnCana Wyoming operations. This list can be revised as needed to incorporate new materials. Materials of greatest concern are those with RQs of 500 gallons or less as that is a feasible quantity that may be spilled.

<http://law.justia.com/us/cfr/title40/40-21.0.1.1.6.0.6.6.html>

APPENDIX B.2

NRBU SPILL REPORTING GUIDELINE AND TABLE

Wyoming DEQ	Wyoming Oil and Gas Conservation Commission	BLM	USEPA
<p><u>**Interpretation from DEQ:</u> <u>Regardless of containment, report any spill quantity of produced water or condensate over 10 barrels or 25 gallons of other manufactured or refined material.</u></p> <p>Report all spills of the following if they enter or threaten surface water (including wetlands) or groundwater:</p> <ul style="list-style-type: none"> - Hazardous Substances* (any volume) - Greater than 10 barrels of any combination of crude oil, condensate, and/or produced water - 25 gallons or more of refined oil products including but not limited to motor oil, lubricating oil, used oil, gasoline, diesel - Suspected release from storage tank (not due to load/unload operations) due to structural or operational failure <p>Immediate notification to 307-777-7781 is required</p> <p>Immediate action to stop and contain release is required</p> <p>Immediate correction of problem that caused spill is required</p> <p>Within 7 days file written report</p>	<p>Report by the next business day, all uncontained spills that enter or threaten to enter waters of the state</p> <p>Written report must be filed within 15 days</p>	<p>Notify BLM verbally immediately on Federal leases: oil, produced water, or toxic liquid exceeding 100 bbls or any spill which occurs in a sensitive area. Written report within 15 days.</p>	<p>Report all oil spills to navigable waters or shorelines that</p> <ul style="list-style-type: none"> - Violate water quality standards - Cause a film or sheen or discoloration of the water or shoreline - Cause a sludge or emulsion to be deposited beneath the surface or on shoreline
	<p>Spills less than 10 barrels that do not physically enter waters of the state and are immediately contained, cleaned up, and properly disposed do not need to be reported</p>		
	<p><u>**The WOGCC rules for spill reporting are currently undergoing revision and are expected to be more stringent.</u></p>	<p>All reporting is to district engineer or supervisor as directed by the district office</p>	<p>Immediate notification to the National Response Center 800-424-8802</p> <p>Ask if written follow up is required</p>
		<p>Spills less than 10 barrels in non-sensitive areas must be included on monthly report of operations</p>	

*Hazardous substances are described in a separate table.

APPENDIX B.3

NRBU REGULATORY LINKS

Wyoming Regulatory Links

WOGCC Spill Information

<http://wogcc.state.wy.us/craig/spill.htm>

WDEQ Spill Information

<http://deq.state.wy.us/out/spills.htm>

Requirements for Reporting on BLM Land

http://www.blm.gov/wy/st/en/programs/energy/Oil_and_Gas/docs/ntl_3a.html

Selected EPA Regulatory Links

Reporting for Oil and Hazardous Substances

<http://law.justia.com/us/cfr/title40/40-21.0.1.1.6.0.6.6.html>

<http://law.justia.com/us/cfr/title40/40-21.0.1.1.6.0.6.3.html>

APPENDIX B.4

NRBU DEFINITION AND NOTIFICATION OF SPILL OR LEAK

ALL AGENCY NOTIFICATIONS TO BE DONE BY EH&S COORDINATOR OR FIELD OPS MANAGER

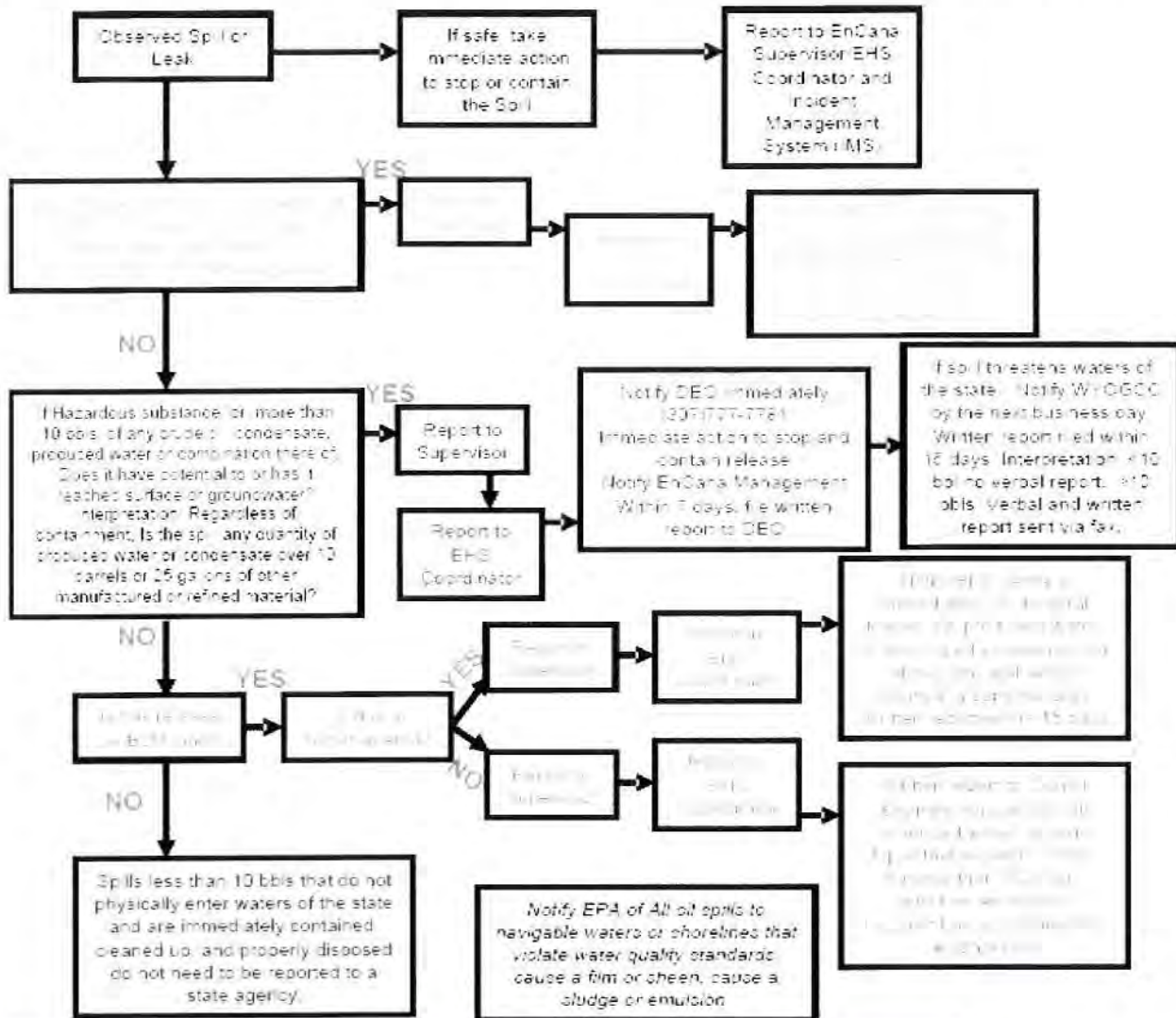

ENCANA SPILL DEFINITION
A spill is any unpermitted quantity of liquid or solid substance that is partially or wholly outside of its primary containment (e.g., tank, drum, truck, pond, pit, storage sack, rig trench), excluding beverages, food items, and potable water

Notification (By Agency):
DEQ: All spills of the following if threatening surface or ground water: Hazardous substances, More than 10bbls of any crude oil, condensate, produced water or combo. Interpretation: Regardless of containment, any spill of produced water or condensate 10bbls or greater, 25 gals or more of refined crude oil product, hazardous substance or any amount or any substance that might threaten to enter waters of the state must be reported.
WYOGCC: By next business day, all spills that threaten to enter waters of state.
BLM: Verbal report within 24 hours on Federal leases of oil, produced water or toxic liquid exceeding 100bbls or any spill which occurs in a sensitive area.
EPA: All oil spills to navigable waters or shorelines that violate water quality standards, cause a film or sheen, cause a sludge or emulsion. Report all spills of Hazardous substances that exceed Reportable Quantities.

APPENDIX C.1

**REGULATORILY REQUIRED SPILL REPORTING
MATRICES FOR SOUTH ROCKIES BUSINESS UNIT**

Note: The use of these Spill Reporting Documents does not preclude the use and importance of each field's Emergency Management Plan.

Spill Reporting Documents (matrices/flowcharts) are to be updated by BU EH&S personnel on a monthly basis and all potential spill response or affected personnel notified if an actual change is made to the document or its location is changed.

APPENDIX C.2

SPILL REPORTING FLOWCHART – DJ BASIN, PICEANCE, PARADOX, COLORADO

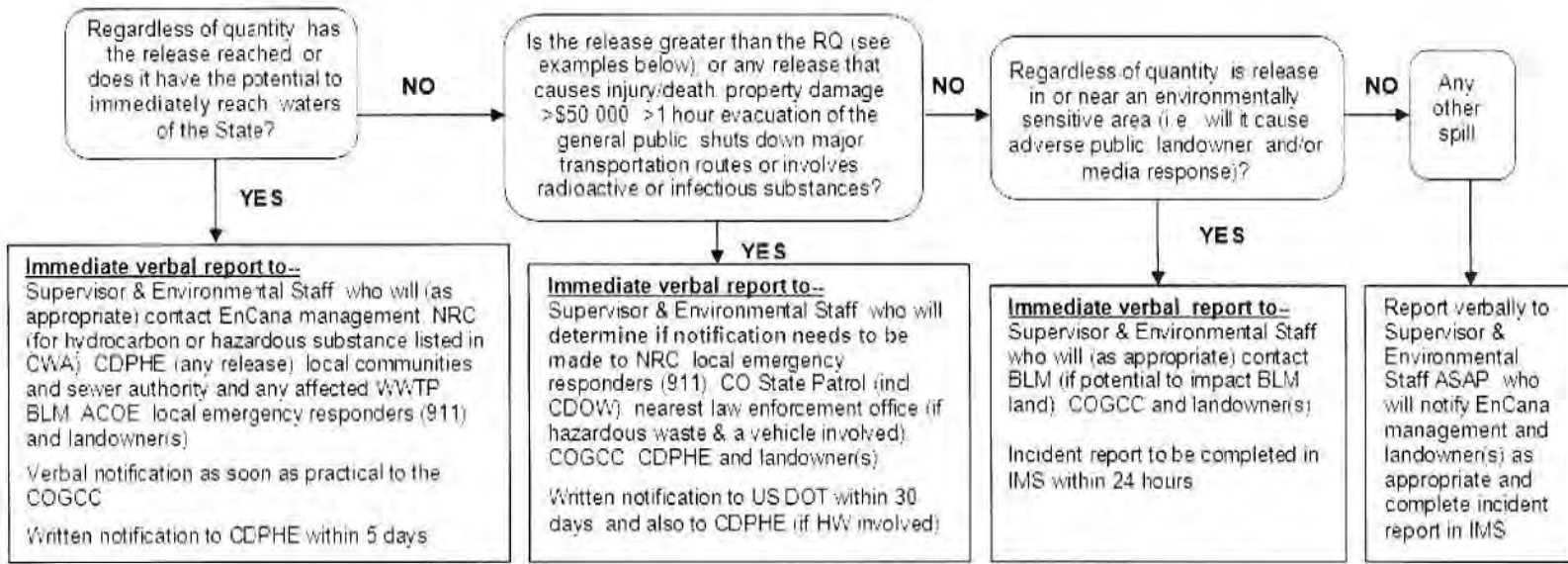

EXAMPLES OF REPORTABLE QUANTITIES (RQ) OF HAZARDOUS SUBSTANCES

Condensate	5 Bbl	(210 gallons)
Produced Water	5 Bbl	(210 gallons)
Frac fluids	5 Bbl	(210 gallons)
Gasoline	25 gallons	
Diesel	25 gallons	
Hydraulic oil	25 gallons	(Stationary source)
Ethylene Glycol (EG)	5,000 lbs	(538 gallons)
Methanol	5,000 lbs	(757 gallons)
Triethylene Glycol (TEG)	no listed reportable quantity – follow guidance above in flow chart	

Note: Any spill/release of E&P waste (including produced fluids) >5 barrels including those within unlined berms, must be reported to COGCC using Form 19 within 10 days of discovery of the spill/release. In addition, ANY spill/release >20 barrels of E&P waste shall be reported verbally to the COGCC within 24 hours. Storage tank releases and pipeline releases have unique requirements—refer to Internet resources.

APPENDIX C.3

SPILL REPORTING FLOWCHART – PARADOX, UTAH

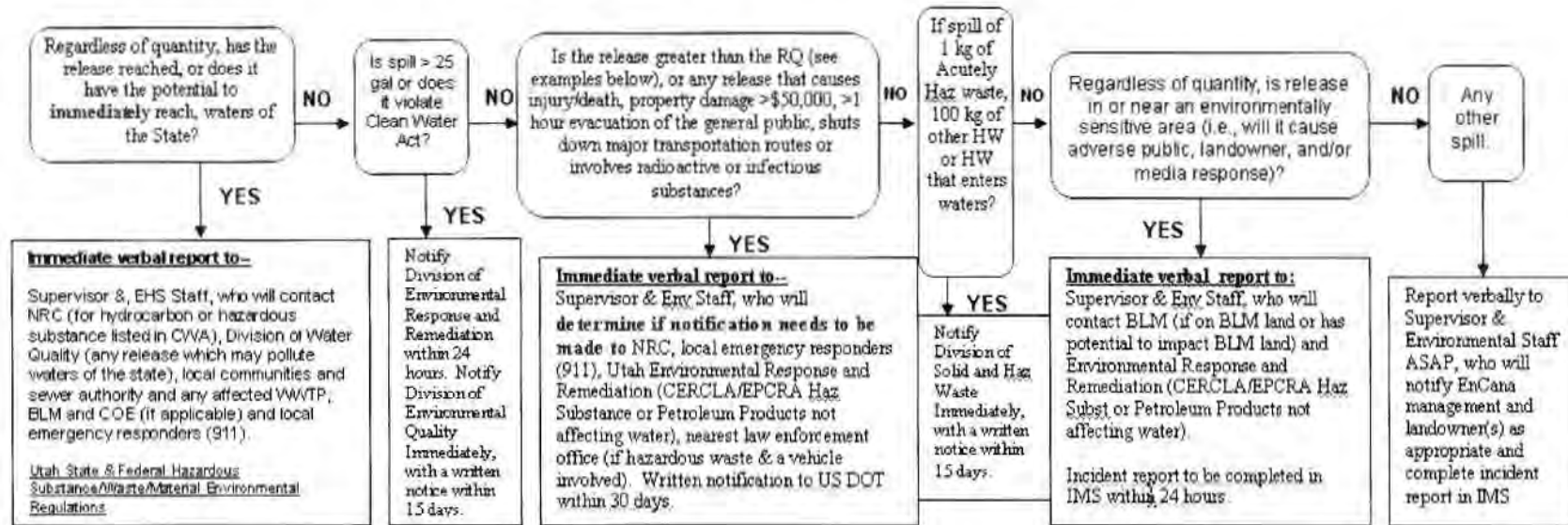

EXAMPLES OF REPORTABLE QUANTITIES (RQ) OF HAZARDOUS SUBSTANCES

Condensate	5 Bbl	210 gal	
Produced Water	5 Bbl	210 gal	
Ethylene Glycol (EG)		545 gal	5,000 lbs
Mercury	1 fl oz		1 lb
Methanol		750 gal	5,000 lbs
Triethylene Glycol (TEG)	no reportable quantity		

- follow guidance above in flow chart

Note:
Div. of Water Quality: Spills of substances which could pollute waters of the state.
Div. of Environmental Response and Remediation: Spill over 25 gallons, causes a sheen on surface water, more than RQ of a CERCLA hazardous substance to environment or violates Clean Water Act.
Div. of Environmental Quality: Used oil spills greater than 25 gallons or potential threat to human health or environment.
Div. of Solid and Hazardous Waste: Spill of one kg of "acutely hazardous material", 100 kg of other hazardous waste, lesser quantity that is a threat to environment. Immediate notification with a written notice within 15 days.
BLM: Verbal report within 24 hours on Federal leases of oil, produced water or toxic liquid exceeding 100 bbls or any spill which occurs in a sensitive area.
EPA: All oil spills to navigable waters or shorelines that violate water quality standards, cause a film or sheen, cause a sludge or emulsion. Report all spills of Hazardous substances that exceed Reportable Quantities.

APPENDIX C.4

SPILL REPORTING FLOWCHART – SOUTH & WEST TEXAS

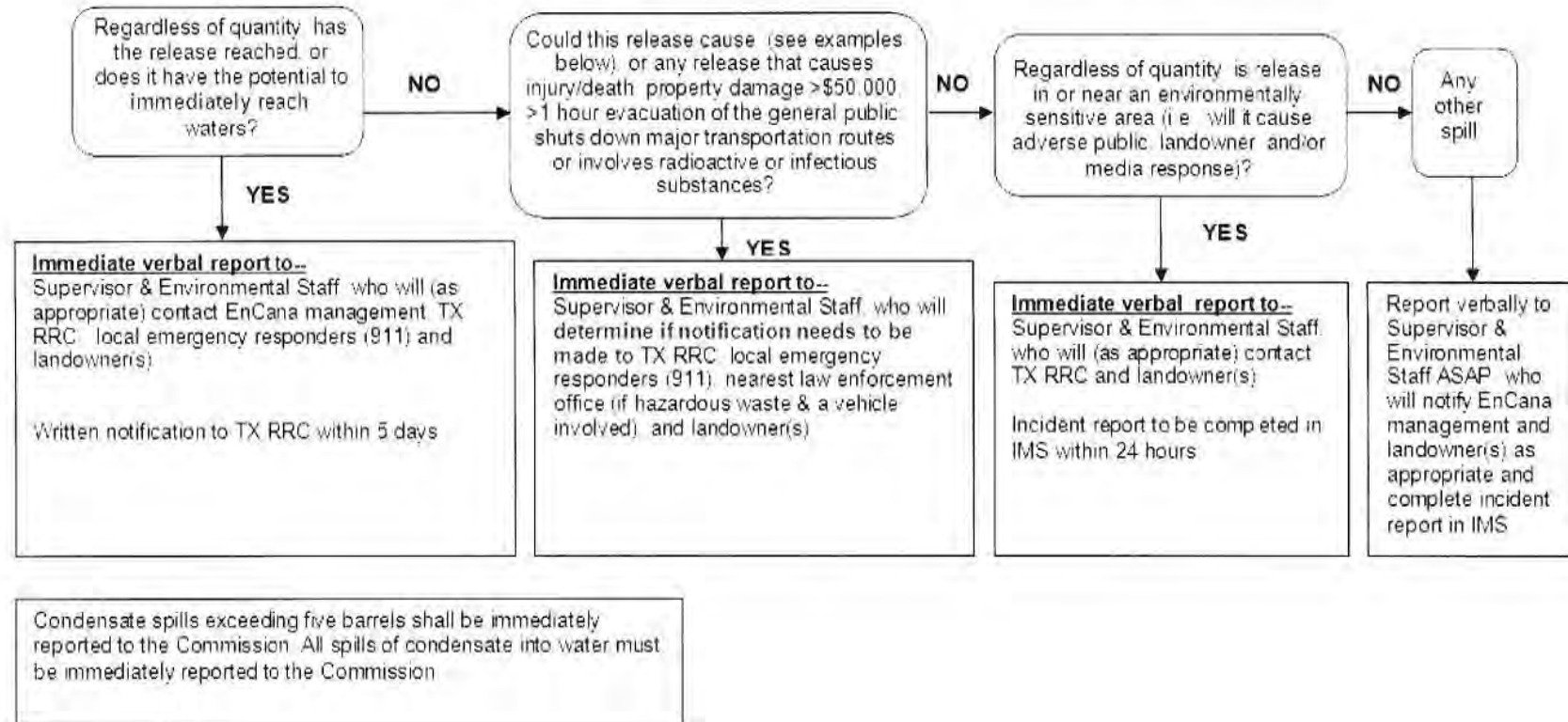

APPENDIX C.5

SRBU REGULATORY LINKS

Colorado Regulatory Links

Spill Guidance Document

<http://www.cdphe.state.co.us/wq/WhatsNew/SpillGuidanceDocument.pdf>

Environmental Spill Reporting Brochure

<http://www.cdphe.state.co.us/hm/spillreportingbroch.pdf>

Spill Release Rules

<http://cogcc.state.co.us/> (under rules: 200 series, 300 series, 600 series, 900 series)

Reportable spills and reporting requirements for spills/releases (COGCC Rule 906 b)

- (1) Spills/releases of E&P waste or produced fluid exceeding five (5) barrels, including those contained within lined or unlined berms, shall be reported on COGCC Spill/Release Report, Form 19.
- (2) Spills/releases which exceed twenty (20) barrels of an E&P waste shall be reported on COGCC Spill/Release Report, Form 19, and shall also be verbally reported to the Director as soon as practicable, but not more than twenty-four (24) hours after discovery.
- (3) Spills/releases of any size which impact or threaten to impact any waters of the state, residence or occupied structure, livestock, or public byway shall be reported on COGCC Spill/Release Report, Form 19, and shall also be verbally reported to the Director as soon as practicable, but not more than twenty-four (24) hours, after discovery.
- (4) Spills/releases of any size which impact or threaten to impact any surface water supply area shall be reported to the Director and to the Environmental Release/Incident Report Hotline (1-877-518-5608). Spills and releases that impact or threaten a surface water intake shall be verbally reported to the emergency contact for that facility immediately after discovery.
- (5) For all reportable spills, operators shall submit a Spill/Release Report, Form 19, within ten (10) days after discovery. An 8 1/2 x 11 inch topographic map showing the governmental section and location of the spill shall be included. Such report shall also include information relating to initial mitigation, site investigation, and remediation. The Director may require additional information.
- (6) Chemical spills and releases shall be reported in accordance with applicable state and federal laws, including the Emergency Planning and Community Right-to-Know Act, the Comprehensive Environmental Response, Compensation, and Liability Act, the Oil Pollution Act, and the Clean Water Act, as applicable.

Texas Regulatory Links

Field Guide for the Assessment and Cleanup of Soil and Groundwater Contaminated with Condensate from a Spill Incident

<http://www.rrc.state.tx.us/environmental/spills/spillcleanup.php>

Texas Railroad Commission Cleanup of Soil Contaminated by a Crude Oil Spill

[http://info.sos.state.tx.us/pls/pub/readtac\\$ext.TacPage?sl=R&app=9&p_dir=&p_rloc=&p_tloc=&p_ploc=&pg=1&p_tac=&ti=16&pt=1&ch=3&ri=91](http://info.sos.state.tx.us/pls/pub/readtac$ext.TacPage?sl=R&app=9&p_dir=&p_rloc=&p_tloc=&p_ploc=&pg=1&p_tac=&ti=16&pt=1&ch=3&ri=91)

Field Guide for Reportable Surface Releases of Crude Oil in Non-Sensitive Areas

<http://www.rrc.state.tx.us/environmental/spills/spillincident.php>

[APPENDIX C.5](#)

SRBU REGULATORY LINKS

Utah Regulatory Links

Utah Department of Environmental Quality Environmental Laws

http://www.deq.utah.gov/Laws_Rules/index.htm

A Summary of Utah State and Federal Hazardous Substance/Waste/Material Environmental Regulations Requiring Immediate to Within 24 Hour Notification of Utah DEQ or EPA

<http://www.superfund.utah.gov/docs/deqspillreport.pdf>

APPENDIX D

Roles and Responsibilities in Spill Incident

- Employee/Contractor that discovered spill
 - Report to supervisor
 - If safe, take action to contain or stop the spill/leak
 - Any individual can report and incident to IMS.
- Supervisor
 - Receives initial report
 - Responsible for Incident Investigation
 - At least one corrective action must be taken
 - Notify EH&S Field Coordinator
- EH&S Field Coordinator or Production Coordinator or Environmental Field Coordinator
 - Responsible for the Investigation Review
 - Notify Environmental/Safety/Field Ops Group Lead
 - Notifications to agencies for significant/reportable spills, if needed
- Environmental Group Lead or Safety Group Lead or Field Ops/Construction/D&C Group Lead
 - Notify Team Lead or EH&S Group Leads if reaches Level 3 incident
 - Notifications to agencies for significant/reportable spills, if needed
- EH&S Group Leads or Team Leads
 - Notification to VP of Business Unit for significant/reportable spills
 - Business unit assigns appropriate personnel to review and close incident when all corrective actions have been closed.
- VP Business Unit
 - Knowledge of significant/reportable incident
 - Business unit assigns appropriate personnel to review and close incident when all corrective actions have been closed.

Reportable Spills for IMS

The reportable spills/environmental releases in this document go above and beyond that defined at the Corporate EH&S level, this is to ensure employee and contractor responsibility to the environment.

<http://ecn.encana.com/ehs/Corporate/docs/Reporting%20Guide.pdf>

Where and How to Capture Spill Information

IMS can be filled out by any individual. Once the Supervisor received the Initial report, they are responsible for the incident investigation, where at least one corrective action must be taken.

Further information located in the IMS User Guide (link on the EH&S homepage)

<http://ecn.encana.com/ehs/>

Timeline for Reporting

IMS should be reported to immediately or within a reasonable amount of time after spill discovery.

For spills reportable to the state, BLM, etc., the timeline varies by reporting agency. See the spill response flowcharts for each Basin/Business Unit

APPENDIX E

FREQUENTLY ASKED QUESTIONS

What air emissions are included in 'environmental releases'?

Fugitive emissions are not included. Emissions to an environmental release include evaporation of toxic chemicals to the air from a spilled substance, within secondary containment or outside of it.

Do the spill flow charts override the Emergency Response Plans?

No. The Emergency Response Plans for all fields come first. The flow charts are a guide to smaller level spills and reporting to IMS and outside agencies.

What are Reportable Quantities?

40 CFR 302.4 table, see next page for calculated volumes based on fluids commonly used in our field operations. Reportable quantities are defined on pages 11-12 in the Wyoming guidance.

What are common contaminants found in our field operations that are on the Reportable Quantities list?

What are their Reportable Quantities?

- Benzene: 100 pounds
- N-hexane: 5000 pounds
- Methanol: 5000 pounds
- Toluene: 1000 pounds
- Xylene: 100 pounds

Who contacts the agencies, if needed?

This task is done by the EH&S Field Coordinator.

How are cumulative events, such as drips or leaks, managed?

Fix repeated drips or leaks as soon as possible to avoid a reportable spill.

APPENDIX F

CALCULATIONS FOR 40 CFR 302.4 REPORTABLE QUANTITIES

Use the link below to access a calculating tool for a material's reportable quantity.

<http://livelinkusa.encana.com/livelinkusa/livelink.exe?func=ll&objid=23626179&objAction=browse&sort=name&viewType=1>

Material	Hazardous Constituent	CAS Number	Hazardous Constituent (wt %)	Hazardous Constituent RQ (lbs)	Specific Gravity	Specific Density (lb/gal)	Density of Water (lb/gal)	Material RQ (gals)	Material RQ (bbl)
OTHER									
Condensate (Sweet)	n-Hexane		50	5000	0.75	-	8.33	1,601	38.11
	Benzene		1	100	0.75	-	8.33	1,601	38.11
Condensate (Sour)	n-Hexane		50	5000	0.7	-	8.33	1,715	40.83
	Benzene		1	100	0.7	-	8.33	1,715	40.83
	Hydrogen Sulfide		0.0002	100	0.7	-	8.33	8,574,859	204,163.30
Produced Water (sour)	n-Hexane		1	5000	1.1	-	8.33	54,567	1,299.22
	Benzene		1	100	1.1	-	8.33	1,091	25.98
	Hydrogen Sulfide		0.1	100	1.1	-	8.33	10,913	259.84
Produced Water (Sweet - Deep Gas)	n-Hexane		1	5000	1.1	-	8.33	54,567	1,299.22
	Benzene		1	100	1.1	-	8.33	1,091	25.98
MultiChem DF7120 Defoamer Emulsion Breaker	Xylene*		0.0001	100	0.876	-	8.33	13,704,112	326,288.38
Multichem FA-4001 Foaming Agent/Corrosion Inhibitor	Ethylene Glycol		58	5000	1.056	-	8.33	980	23.33
	Methanol		8	5000	1.056	-	8.33	7,105	169.17
Multichem FA-4013 Foaming Agent/Corrosion Inhibitor	Methanol		25	5000	0.984	-	8.33	2,440	58.10
Multichem FA-4500 Low Temperature Foamer	Ethylene Glycol		60	5000	-	-	-	-	-
	Methanol		10	5000	-	-	-	-	-
Multichem HI-1000 Hydrate Inhibitor	Methanol		40	5000	-	8.28	8.33	1,510	35.94

	Ethylene Glycol		15	5000	-	8.28	8.33	4,026	95.85
Multichem MX365-4 Foaming Agent	Methanol		25	5000	-	8.05	8.33	2,484	59.15
Multichem P-3139 Paraffin/Asphlatene Dispersant	Toluene			1000	0.771				
Multichem P-3319 Paraffin Inhibitor	Toluene			1000	0.8659				
Multichem S-2008 Scale Inhibitor	Methanol		30	5000	0.995	-	8.33	2,011	47.88
Multichem S-2009 Scale Remover	Hydrochloric acid		3	5000	1.086	-	8.33	18,424	438.66
	Ethylene Glycol		50	5000	1.086	-	8.33	1,105	26.32
Gasoline, unleaded	Benzene		4.9	100	0.78	-	8.33	314	7.48
	Ethyl benzene		3	1000	0.78	-	8.33	5,130	122.15
	n-Hexane		4	5000	0.78	-	8.33	19,238	458.06
	Methyl tert-butyl ether		15	1000	0.78	-	8.33	1,026	24.43
	Toluene		25	1000	0.78	-	8.33	616	14.66
	Xylene		15	100	0.78	-	8.33	103	2.44
Multichem P-3200	Xylene		80	100	0.8681	-	8.33	17	0.41
	Ethyl benzene		15	1000	0.8681	-	8.33	922	21.95
Multichem WC-7579 Water Clarifier	Ethylene Glycol		70	5000	1.136	-	8.33	755	17.97
Methanol	Methanol		100	5000	0.791	-	8.33	759	18.07
OSW5200 Oxygen Scavenger	Ammonium bisulfate		100	5000	1.347	-	8.33	446	10.61
	Nickel sulfate		1	100	1.347	-	8.33	891	21.22
Tretolite RBW264 Water Clarifier	Ethylene Glycol		30	5000	1.155	-	8.33	1,732	41.25
Triethylene Glycol	Ethylene Glycol		0.1	5000	1.1	-	8.33	545,673	12,992.21
Ethylene glycol	Ethylene Glycol		90	5000	1.135	-	8.33	588	13.99
Multichem EB-1410 Emulsion Breaker	Xylene		26	100	0.8915	-	8.33	52	1.23
Mercury in thermometers	Mercury		100	1	13.59	-	8.33	0.009	0.0002
Polyken 1027 Primer	Toluene		12	1000	1.03	-	8.33	971	23.13
	Methanol		1.5	5000	1.03	-	8.33	38,850	925.01
COMPLETIONS CHEMICALS									
Water Friction-Reducing Agent B400	Ammomium chloride	12125-02-9	5	5000	-	1.1	8.33	90,909	2,164.50

	Aromatic solvent	Proprietary	30	NA	-	1.1	8.33		
	Aromatic solvent	Proprietary	30	NA	-	1.1	8.33		
PSG Polymer Slurm B306	Gum: Gum	9000-30-0	80	NA	-	1.1	8.33		
	Hydrocarbon solvent		80	NA	-	1.1	8.33		
Breaker J213	Diammonium peroxodisulfate	7727-54-0	100	NA	-	2	8.33		
Liquid Breaker Acid J318	2,2,2-trinitroethanol	102-71-9	100	NA	-	1.1	8.33		
EB-Clean™ J475 Breaker	Diammonium peroxodisulfate	7727-54-0	100	NA	-	2	8.33		
Temporary Clay Stabilizer L64	Tetramethyl ammonium chloride	75-57-0	80	NA	-	1	8.33		
20/40-Mesh Sand S20	Crystalline silica	14808-60-7	100	NA	-	2.5	8.33		
Non-Emulsifying Agent W54	Methanol	67-56-1	70	5000	-	0.9	8.33	7,937	188.96
	Heavy aromatic napthalene	64742-94-9	5	NA	-	0.9	8.33		
	Oxyalkylated alcohol (2)	Proprietary	10	NA	-	0.9	8.33		
	Oxyalkylated alkyl alcohol (1)	Proprietary	10	NA	-	0.9	8.33		
	Synthetic resin	Proprietary	10	NA	-	0.9	8.33		
	Oxyalkylated alcohol (3)	Proprietary	5	NA	-	0.9	8.33		
	Quaternary ammonium compound	Proprietary	5	NA	-	0.9	8.33		
M295L Industrial Antimicrobial	Tetraakis(hydroxymethyl) phosphonium sulfate	55566-30-8	100	NA	1,375	-	8.33		
Stabilizer/Delay Agent J511	Aliphatic polyep	Proprietary	100	NA	-	1.5	8.33		
J920 Component-Crosslinker L19	Boric Acid	10043-35-3	100	NA	-	1.4	8.33		
J920 Component-Activator M7	Sodium hydroxide	1310-73-2	60	1000	-	1.5	8.33	1,111	26.46
Green-Cide 25G B244	Glutaraldehyde	111-30-8	25	NA	1,087.5	-	8.33		

Super LC/SOT4L 1-1220	Crystalline silica	14808-60-7	100	NA	-	2.6	8.33		
	Phenol-formaldehyde Resin	57891-91-8	5	NA	-	2.6	8.33		
30/50 Mesh Sand ST9	Crystalline silica	14808-60-7	not provided	NA	-	2.6	8.33		
Alpha 452	Phosphonium tetrakis (hydroxymethyl)-sulfate	055566-30-8	40	NA	1.64	-	8.33		
Caustic Soda, Liquid	Sodium Hydroxide	1310-73-2	50	1000	1.53	-	8.33	157	3.74
Clay Treat#30	Tetramethyl ammonium chloride	75-57-0	80	NA	1.02	-	8.33		
FRW-14	Hydroreated light distillate	64742-47-6	40	NA	0.08	-	8.33		
	Ethoxylated alcohol	68439-50-8	5	NA	1.03	-	8.33		
GBW4F	Ammonium Persulfate	7727-54-0	95	NA	1.9	-	8.33		
GBW-33L	White mineral oil	8042-47-5	90	NA	0.96	-	8.33		
	Magnesium hydroxide	1309-42-8	3	NA	0.95	-	8.33		
	Magnesium peroxide	14452-57-4	3	NA	0.95	-	8.33		
	Magnesium oxide	1309-48-4	2	NA	0.96	-	8.33		
GWOLDF	Petroleum Distillate-Bulk	Proprietary	70	NA	1.07	-	8.33		
	Guar gum	009000-30-0	40	NA	1.07	-	8.33		
High Perm CRB	Ammonium Persulfate	007727-54-0	100	NA	1.73	-	8.33		
	Crystalline silica quartz	014808-60-7	15	NA	1.72	-	8.33		
High Perm CRB-LT	Ammonium Persulfate	7727-54-0	60	NA	-	-	8.33		
	Crystalline silica	7631-86-9	12	NA	-	-	8.33		
Magnacide 575 Microbiocide	Tetrakis(hydroxymethyl) phosphonium sulfate	55566-30-8	100	NA	1.375	-	8.33		
NE-940	Methanol	67-56-1	60	5000	0.88	-	8.33	1,137	27.07
	2-ethylhexanol	104-76-7	10	NA	0.88	-	8.33		
	Isopropanol	67-63-0	10	NA	0.88	-	8.33		
	Heavy aromatic naphtha	64741-54-5	5	NA	0.88	-	8.33		
	Polyethylene	25322-68-3	5	NA	0.88	-	8.33		

	glycol								
	EO-C7-9-iso-C8-rich alcohols	78330-20-8	5	NA	0.88	-	8.33		
	EO-C9-11-iso-C10-rich alcohols	78330-20-8	5	NA	0.88	-	8.33		
	Naphthalene	91-20-3	1	100	0.88	-	8.33	1,364	32.48
XLW-30AG	Hydrotreated light distillate	064742-47-8	70	NA	1.07	-	8.33		
XLW-32	Methanol	64-56-1	90	5000	0.885	-	8.33	754	17.94
	Boric oxide	1303-86-2	20	NA	0.855	-	8.33		

Day-to-day Chemicals

Napa Antifreeze Coolant NP001	Ethylene Glycol	107-21-1	100	5000	-	9.41	8.33	531	12.65
	Diethylene Glycol	111-46-6	5	NA	-	9.41	8.33		
	Inorganic Salt	NJTS# 254504001-5237	5						
Arctictherm E-50	Ethylene Glycol	107-21-1	50	5000	1.068	-	8.33	1,124	26.76
Valvoline ATF Dexron III/Marcon Automatic Transmission Fluid	Distillates (Petroleum) Hydrotreated Heavy Paraffinic	64742-54-7	80	NA	-	7.26	8.33		
Johnson's Baby Powder	Talc	14807-96-6	99	NA	Not listed	Not listed	8.33		
NAPA/CRC Brakleen Brake Parts Cleaner-Non-chlorinated	Acetone	67-64-1	60	5000	0.811	-	8.33	1,234	29.37
	Toluene	108-88-3	35	1000	0.811	-	8.33	423	10.07
	Methanol	67-56-1	25	5000	0.811	-	8.33	2,960	70.49
Condensate (Sweet)	Pentanes	109-66-0	80	NA	0.75	-	8.33		
	n-Hexane	110-54-3	50	5000	0.75	-	8.33	1,601	38.11
	Butanes	106-97-8	10	NA	0.75	-	8.33		
	Benzene	71-43-2	1	10	0.75	-	8.33	160	3.81
HD Fleet Engine Oil (All Grades)	Lubricant Base Oil (Petroleum)	Various	87		0.88	-	8.33		

	Additives	Proprietary	12	NA	0.89	-	8.33		
Diesel #1	#1 Diesel	8008-20-6	100	NA	0.9	-	8.33		
	Toluene	108-88-3	0.5	1000	0.9	-	8.33	26,677	635.17
	Napthalene	91-20-3	0.5	100	0.9	-	8.33	2,668	63.52
Diesel #2	#2 Diesel	68476-34-6	100	NA	0.9	-	8.33		
	Toluene	108-88-3	0.5	1000	0.9	-	8.33	26,677	635.17
	Napthalene	91-20-3	0.5	100	0.9	-	8.33	2,668	63.52
Ultra Max LR150 (Soap Stick)	Polyethylene Glycol	25322-56-3	100	NA	1.056	-	8.33		
Klean-Break	Isopropyl Alcohol	67-63-0	30	NA	0.86	-	8.33		
	2-Ethyl Hexanol	104-76-7	30	NA	0.86	-	8.33		
	Methanol	67-56-1	13	5000	0.86	-	8.33	5,369	127.83
	Refinates (Petroleum) Distillation Sorption Process	NA	60	NA	0.86	-	8.33		
Kolor Cut Modified Water Binding Paste	Non-Hazardous	NA	NA	NA	1.1	-	8.33		
Kodir Kote	Lubricating Grease	74868219	60	NA	-	9.6	8.33		
	Nonhazardous Blend	7782435	Total 30	NA	-	9.6	8.33		
		1317335	Total 30	NA	-	9.6	8.33		
		13778744	Total 30	NA	-	9.6	8.33		
		471341	Total 30	NA	-	9.6	8.33		
	Metalllic Copper	7440508	10	NA	-	9.6	8.33		
Pyroil White Grease (Lithium)	Heptane	142-85-6	70	NA	No Data	No data	8.33		

	Distillates (Petroleum) Hydrotreated Heavy Napht	64742-52-5	15	NA	No Data	No data	8.33		
Biocide MC B-8630	Acetone	67-64-1	40	5000	0.9868	-	8.33	1,521	36.21
	Glutaraldehyde	111-30-8	30	NA	0.9868	-	8.33		
MC FA-4500 Foaming Agent	2-Butoxyethanol	111-76-2	10	NA	1.084	-	8.33		
	Ethylene Glycol	107-21-1	33	5000	1.084	-	8.33	1,678	39.95
MC DF-7120 Defoamer/Emulsion Breaker	Aromatic Solvent	64741-68-0	75	NA	0.876	-	8.33		
	Xylene	1330-20-7	25	100	0.876	-	8.33	55	1.31
	Isopropyl Alcohol	67-63-0	Confidential ≤25	NA	0.876	-	8.33		
MC FA-4001 Foaming Agent/Scale & Corrosion Inhibitor Combination	Ethylene Glycol	107-21-1	58	5000	1.056	-	8.33	980	23.33
	Ethylene Glycol Monobutyl Ether	111-76-2	11	NA	1.056	-	8.33		
	Proprietary Blend	Proprietary	8	NA	1.056	-	8.33		
	Methanol	67-56-1	8	5000	1.056	-	8.33	7,105	169.17
MC FA-4013 Foaming Agent/Scale and Corrosion Inhibitor	Ethylene Glycol Monobutyl Ether	111-76-2	12	NA	0.984	-	8.33		
	Methanol	67-56-1	25	5000	0.984	-	8.33	2,440	58.10
	Alcohols, C6-10 ethoxylated, sulfate, ammonium salts	68037-05-8	8	NA	0.984	-	8.33		

	Anionic surfactants	Proprietary	20	NA	0.984	-	8.33		
	Proprietary Blend	Proprietary	12	NA	0.984	-	8.33		
	Isopropanol	67-63-0	3	NA	0.984	-	8.33		
MC FA-4295 Foamer	Methanol	67-56-1	25	5000	0.9677	-	8.33	2,481	59.07
	Ethylene Glycol Monobutyl Ether	111-76-2	10	NA	0.9677	-	8.33		
	Ethylene Glycol	107-21-1	5	5000	0.9677	-	8.33	12,405	295.37
	Isopropanol	67-63-0	5	NA	0.9677	-	8.33		
MC FS-7504 Foam Sticks	None	NA	NA	NA					
MC FS-7584 Foam Sticks	None	NA	NA	NA					
MC EB-1790 Emulsion Breaker	Isopropyl Alcohol	67-63-0	1	NA	1.02	-	8.33		
MC WC-7579 Water Clarifier	Ethylene Glycol	107-21-1	70	5000	1.136	-	8.33	755	17.97
Methanol	Methyl Alcohol	67-56-1	99.8	5000	0.7893	-	8.33	762	18.14
	Water	7732-18-5	Trace	NA	0.7893	-	8.33		
Natural Gas (Sweet)	Butanes	108-97-5	10	NA	0.5	-	8.33		
	Ethane	74-84-0	1.9	NA	0.5	-	8.33		
	Methane	74-82-8	90	NA	0.5	-	8.33		
	Propane	74-98-6	10	NA	0.5	-	8.33		
Pipe Dope 2000	Petroleum Grease Mixture	64742-52-5	Total 60	NA	1.2	-	8.33		
		64742-53-6	Total 60	NA	1.2	-	8.33		
		64742-01-4	Total 60	NA	1.2	-	8.33		
		64742-65-7	Total 60	NA	2	-	8.33		

		64742-62-7	Total 60	NA	1.2	-	8.33		
		7620-77-1	Total 60	NA	1.2	-	8.33		
		68783-36-8	Total 60	NA	1.2	-	8.33		
		6848-89-5	Total 60	NA	1.2	-	8.33		
		1310-65-2	Total 60	NA	1.2	-	8.33		
	Copper	7440-50-8	7	5000	1.2	-	8.33	7,146	170.14
	Lime	1305-78-8	5	NA	1.2	-	8.33		
	Talc	14807-96-5	10	NA	1.2	-	8.33		
	Additives: OSHA trade secret WHMIS Non- Hazardous	Proprietary	50	NA	1.2	-	8.33		
Produced Water (Sweet- From Crude Oil or Deep Gas Production)	Sodium chloride	7547-14-05	20	NA	1.1	-	8.33		
	n-Hexane	110-54-3	1	5000	1.1	-	8.33	54,567	1,299.22
	Benzene	71-43-2	1	10	1.1	-	8.33	109	2.60
Pyroil Premium Starting Fluid	n-Heptane	142-32-5	70	NA	-	5.89	8.33		
	Ethyl Ether	60-29-7	30	100	-	5.89	8.33	57	1.35
	Carbon Dioxide	124-38-5	5	NA	-	5.89	8.33		
Transform C	Isopropyl Alcohol	67-53-0	30	NA	0.895	-	8.33		
	Glycol Ethers	111-76-2	10	NA	0.895	-	8.33		
Triethylene Glycol	Triethylene Glycol	112-27-5	99	NA	1.126	-	8.33		
	Diethylene Glycol	111-46-6	5	NA	1.126	-	8.33		
Chevron Regular Unleaded Gasoline	Gasoline	86280-81-3	100	NA	0.6	-	8.33		

	Benzene	71-43-2	4.9	10	0.8	-	8.33	31	0.73
	Ethyl benzene	100-41-4	3	1000	0.8	-	8.33	5,002	119.10
	Naphthalene	91-20-3	2	100	0.8	-	8.33	750	17.86
	Ethanol	64-17-5	10	NA	0.8	-	8.33		
	Methyl tert-butyl ether (MTBE)	1634-04-4	15	1000	0.8	-	8.33	1,000	23.82
	Tertiary amyl methyl ether (TAME)	994-05-3	17	NA	0.8	-	8.33		
	Ethyl tert-butyl ether (ETBE)	637-92-3	18	NA	0.8	-	8.33		
WD-40	Aliphatic Petroleum Distillate	8052-41-3	70	NA	0.816	-	8.33		
	Petroleum Base Oil	64742-65-0	25	NA	0.816	-	8.33		
	Carbon Dioxide	124-38-9	3	NA	0.816	-	8.33		
	Non-hazardous Ingredients	NA	10	NA	0.816	-	8.33		
WSP 9030	Methanol	67-56-1	70	5000	0.962	-	8.33	891	21.22
	Ethylene Glycol	107-21-1	70	5000	0.962	-	8.33	891	21.22
WFT 9527	Toluene	108-88-3	7	1000	0.89	-	8.33	1,927	45.88
	Xylene	1330-20-7	70	100	0.89	-	8.33	19	0.46
	Methyl Isobutyl Ketone	108-10-1	5	5000	0.89	-	8.33	13,489	321.16
	Proprietary Alcohol	Proprietary	5	NA	0.89	-	8.33		
	D-Limonene	5989-27-5	7	NA	0.89	-	8.33		
WFT 97112W (W-CAP)	Methanol	67-56-1	40	5000	1	-	8.33	1,501	35.73
	Isopropanol	67-63-0	3	NA	1	-	8.33		

AFT 9785 (Multi-functional Foaming Agent)	Methanol	67-56-1	30	5000	1.03	-	8.33	1,943	46.25
	Ethoxylated Alcohol	9016-45-9	2	NA	1.03	-	8.33		
WSP 92011	Glycol Ethers	111-76-2	40	NA	0.8527	-	8.33		
	Methanol	67-56-1	40	5000	0.8527	-	8.33	1,760	41.90
WSP 9999	EB-Butyl Cellosolve	111-76-2	60	NA	0.9016	-	8.33		

[\[Back to Appendix Index\]](#)

APPENDIX D

PLAN REVIEW AND AMENDMENT LOGS



300 gal
corrosive
inhibitor

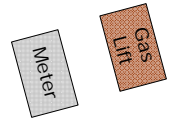

12 bbls
methanol
tank.

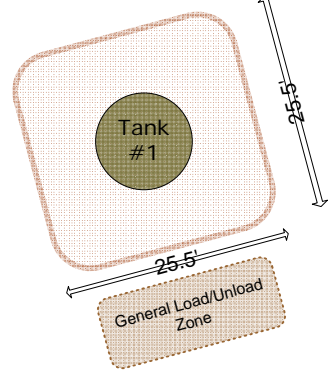

Direction of Flow

300 gal
corrosive
inhibitor

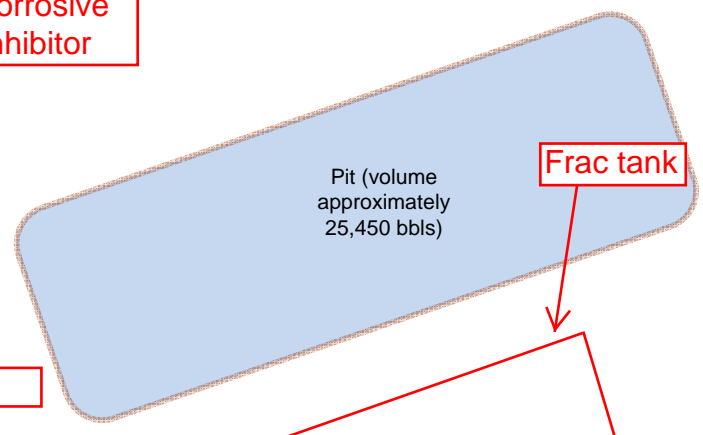
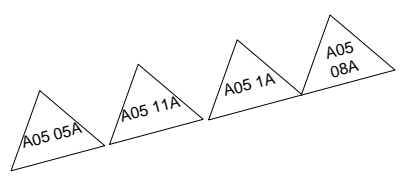

Frac tank

Pump

Metal Berm (lined)
Volume is 326 BBLS
Depth = 3'
Containment is Sufficient

Tank #1
SN 8J601201-06
250 BBL - D=13.5' H=10'
Contents:
Condensate/Produced Water



Pad: A05	
Area: North Parachute Mountain	
Legal: NENE Section 5, T5S, R96W, 6 th PM	
Date: 12/26/12	Drawn By: C. Jensen
Revision Date:	Scale: none





DANGER
NO
SMOKING
FIRE
Hazardous
Materials
120-225-1811
678-321-1310
CAPACITY

CAUTION
KEEP OUT

DANGER
NO SMOKING

GAS CONTROL 970-285-2615/911
1-800-791-7881

encana.
natural gas
970-285-2615 OR
970-301-1319
CAPACITY

PRODUCED WATER
CONDENSATE

WARNING
KEEP OUT
AUTHORIZED PERSONNEL ONLY







EnCana Oil & Gas (USA) Inc.





Secondary Containment Capacity & Calculations

Facility Name: **A05**

Containment ID: **A05**

Route: **North Parachute Mountain**

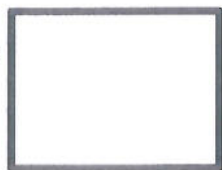
Type of Secondary Containment: **Earth Berm (lined)** Precipitation Event (PE): **25 year, 24-hour** Height of Containment (ft): **1.4**
 Shape: **Rectangular w/square corners** Precipitation Inches: **2.2** Height based on PE (ft): **1.2**

Radius Straight 0.0 Radius 0.0 Straight 0.0  Radius 0.0 Straight 0.0 Radius 0.0 Average Length (ft): 0.0 Average Width (ft): 0.0 Area of Rectangular Base (sq ft): 0 Deduct for Curved Corners (sq ft): 0 Area of Actual Base (sq ft): 0 Gross Volume of Containment (bbls): 0 Volume (w/ PE) of Containment (bbls): 0	Length: 0.0 Width: 0.0  Area of Base (sq ft): 0 Gross Volume of Containment: 0 Volume (w/ PE) of Containment: 0	Length: 48.0 Width: 29.0  Area of Base (sq ft): 1392 Gross Volume of Containment: 347 Volume (w/ PE) of Containment: 302	Diameter: 0.0  Area of Base (sq ft): 0 Gross Volume of Containment (bbls): 0 Volume (w/ PE) of Containment: 0
---------------------------------------------------------------------------------------------------------------------------------------------------------------------------------------------------------------------------------------------------------------------------------------------------------------------------------------------------------------------------------------------------------------------------------------	-----------------------------------------------------------------------------------------------------------------------------------------------------------------------------------------------------------------	---------------------------------------------------------------------------------------------------------------------------------------------------------------------------------------------------------------------------	--------------------------------------------------------------------------------------------------------------------------------------------------------------------------------------------------------------

Tank ID Number	Tank Volume	Tank Diameter	Tank Height	Displacement:
A05-02	250	13.5	10	35.7
A05-01	250	13.5	10	35.7

Volume of Largest Tank:	250
Displacement of Other Tanks:	33
Required Containment Volume:	283

Containment Volume with Precipitation Event (bbls):	302
Percent of Precipitation Event Capacity:	107%

Site Description and Characterization

Facility Name: A05

Route: North Parachute Mountain

Legal Description: NENE Sec: 5 Twp: 5S Range: 96W Meridan: 6

Facility Coordinates: Lat: 39.6499 Long: -108.185431

This section addresses all or portions of 40 CFR 112.7(a)(3)(i), (a)(3)(iii), and § 112.7 (b). Additional site specific information, including facility layout, location, and secondary containment calculations can be found in the figures and documents following this page.

The design and construction of bulk storage containers at EnCana facilities are compatible with the characteristics of the oil product they contain, and with temperature and pressure conditions.

In the past three years, this facility has not had a discharge of oil into or upon the navigable waters of the United States or adjoining shorelines in quantities that may be harmful under the CWA.

Relationship of facility to area surface waters in the event of an accidental release.

Receiving Waters	Relationship to Facility	
Name of nearest recognized surface water	Distance To Nearest Perennial Stream	Direction from
Intermittent drainage to East Fork/Stewart Gulch	900	Northeast

Container Inventory and Potential Failure Assessment

Tank Contents:	Containment:	Tank ID Number	Tank Volume	Tank Diameter	Tank Height	Potential Release Volume:
Produced Water/Condensate	Earth Berm (lin	A05-01	250	13.5	10	250
Produced Water/Condensate	Earth Berm (lin	A05-02	250	13.5	10	250

Notes:

Possible causes of equipment failure include natural disasters, personnel accidents, and acts of terrorism. Direction of release will not be indicated here unless a piece of equipment is likely to discharge in a direction other than that indicated in the site diagram figure.

A “variable” rate of flow is to be expected. This means that the viscosity of the contents of the tank will be affected by ambient temperature and weather conditions.

Potential release volumes will equal container capacity unless multiple tanks are manifolded together or are attached to pipelines which could lead to increased release volumes. For the purposes of this plan, all possible causes of equipment failure were assumed to have equal chance of causing the maximum release volume.



Direction of Flow

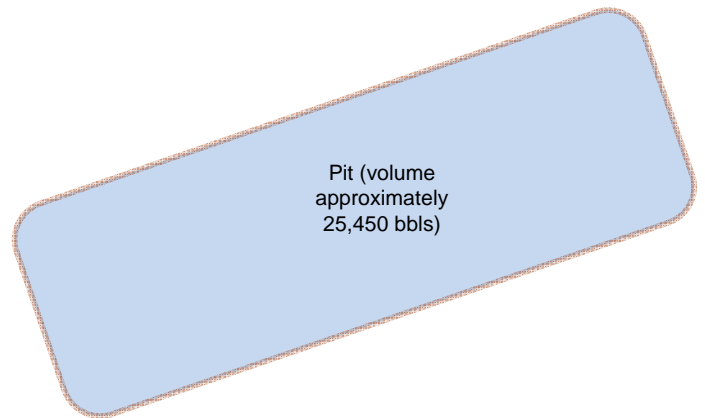
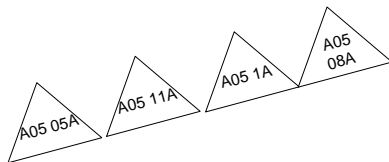

Metal Berm (lined)
 Volume is 326 BBLS
 Depth = 3'
 Containment is Sufficient

Tank #1
 SN 8J601201-06
 250 BBL - D=13.5' H=10'
 Contents:
 Condensate/Produced Water



Pad: A05	
Area: North Parachute Mountain	
Legal: NENE Section 5, T5S, R96W, 6 th PM	
Date: 12/26/12	Drawn By: C. Jensen
Revision Date:	Scale: none