

NOBLE ENERGY INC.
SITZMAN E23-12
NWSW 23-6N-65W
1920' FSL & 590' FWL
Weld County, Colorado
Wattenberg
CURRENT WELLBORE SCHEMATIC
with PROPOSED P&A
1/30/2013

API: 05-123-17854
 COGCC #

GL Elev: 4716
 KB Elev: 4726

Spud Date:

Surface Casing :
 8 5/8" 24# @ 339'
 Cement: 245 sx
 TOC: Surface

Production Casing :
 2 7/8" 6.5# @ 7164'
 Cement: 775sx/215sx
 TD: 2/18/1994

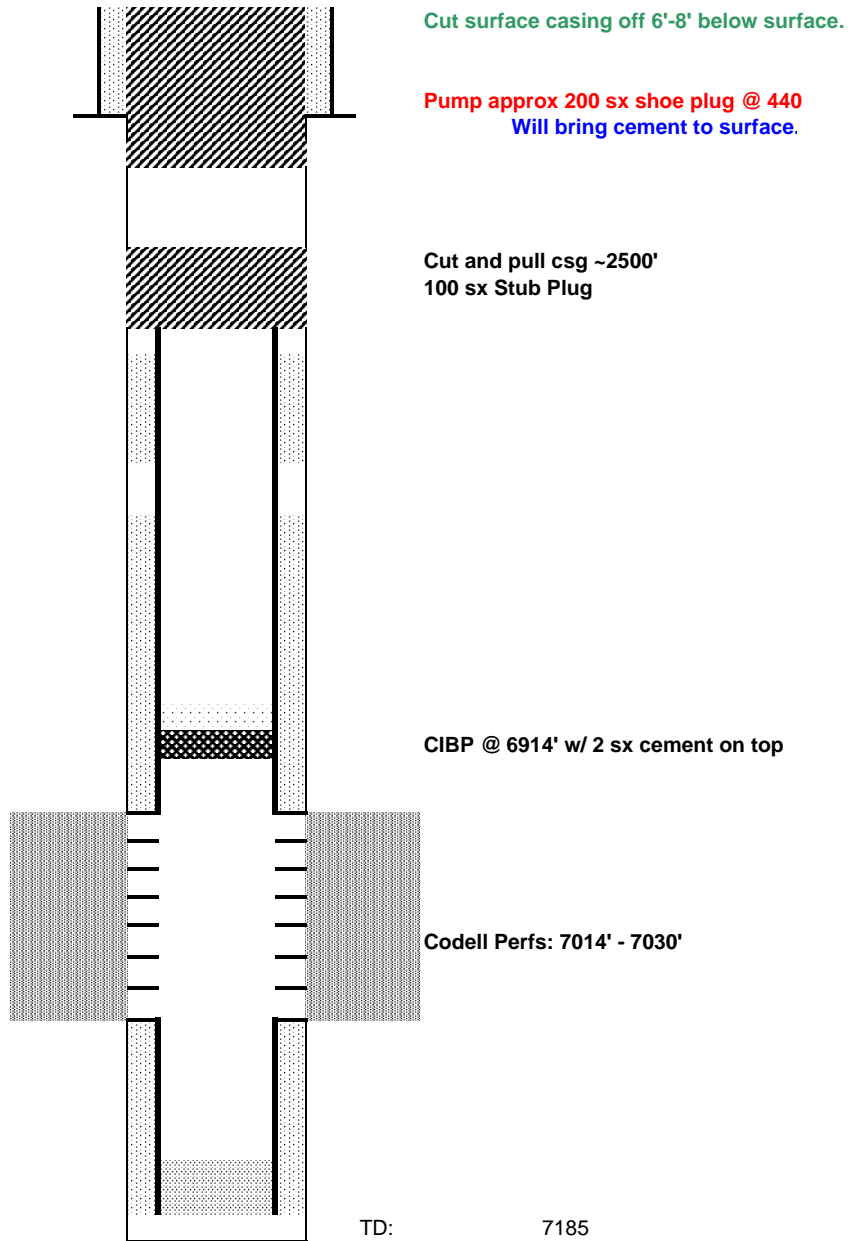

Cut surface casing off 6'-8' below surface.

Pump approx 200 sx shoe plug @ 440
 Will bring cement to surface.

Cut and pull csg ~2500'
 100 sx Stub Plug

TOC @ 2684'

TOC @ 5585'

CIBP @ 6914' w/ 2 sx cement on top

Codell Perfs: 7014' - 7030'

TD: 7185